



**POZNAN UNIVERSITY OF MEDICAL SCIENCES  
CHAIR OF CHEMISTRY AND CLINICAL BIOCHEMISTRY  
DEPARTMENT OF CLINICAL BIOCHEMISTRY**

**Head: Prof. Lech Torliński MD, PhD**

address: 60-780 Poznań  
ul. Grunwaldzka 6  
Collegium Chemicum

tel. + 48 61 854 6590

fax. + 48 61 854 6599

e-mail. [lektor@amp.edu.pl](mailto:lektor@amp.edu.pl)

**Laboratory Medicine:**

[www.chembiochlin.amp.edu.pl](http://www.chembiochlin.amp.edu.pl)

60-529 Poznań, ul. Dąbrowskiego 79/601 – Collegium A. Wrzoska, tel.: +48 61 854 6850 (51) fax: +48 61 854 6857

# **A Guide to Laboratory Medicine**

**for 3<sup>rd</sup> year Students  
of the 4 year MD  
English Language Program**

**2006/2007  
Academic Year**

**GROUP B**

INDEX:	2
Authors.....	3
Copyright .....	3

## PART I Main information

Introduction to the Course of Laboratory Medicine .....	5
Schedule.....	7
Main Topics and Leading Teachers.....	9
Syllabus.....	10

## PART II Review of Laboratory Medicine

Clinical laboratory tests – reference range– <i>Prof. Lech Torliński MD, PhD</i> .....	18
The usefulness of laboratory data in the differential diagnosis of anemia – <i>Wojciech Żak MD</i> .....	26
Basic laboratory tests in the diagnosis and management of haemostatic failure – <i>Wojciech Żak MD</i> .....	35
The evaluation of acid-base balance in clinical practice – <i>Waldemar Myszka MD</i> .....	44
Diagnostic approach to water-electrolyte disturbances – <i>Waldemar Myszka MD</i> .....	51
Biochemical effects of neoplastic diseases – <i>Miłoslawa Zowczak-Drabarczyk MD</i> .....	81
Plasma proteins and laboratory diagnosis of inflammation and infectious diseases – <i>Miłoslawa Zowczak-Drabarczyk MD</i> .....	91
Urinalysis and other laboratory procedures in the diagnosis of the urinary tract disorders – <i>Hanna Kara-Perz MD, Dorota Formanowicz MD</i> .....	98
Kidney failure and clinical basics of dialysis – <i>Dorota Formanowicz MD</i> .....	112
Clinical enzymology and liver function disorders – <i>Miłoslawa Zowczak-Drabarczyk MD</i> .....	124
The application of laboratory methods in the diagnosis and management of ischemic heart disease – <i>Hanna Kara-Perz MD</i> .....	131
The differential diagnosis of disorders of lipid metabolism – <i>Ewa Wysocka MD</i> .....	136
The diagnosis of hyper- and hypoglycemia – <i>Ewa Wysocka MD</i> .....	148
Age-dependent characteristics of laboratory tests – <i>Sylvia Dzięgielewska MD</i> .....	167

## **A U T H O R S :**

**Prof. Lech Torliński MD, PhD**

**e-mail: lechtor@amp.edu.pl**

**Sylwia Dziegielewska MD**

**e-mail: syladzie@hotmail.com**

**Dorota Formanowicz MD**

**e-mail: doforman@amp.edu.pl**

**Hanna Kara-Perz MD**

**e-mail: hkp@op.pl**

**Waldemar Myszka MD**

**e-mail: wmyszka@amp.edu.pl**

**Ewa Wysocka MD**

**e-mail: ewysocka@amp.edu.pl**

**Miłoslawa Zowczak-Drabarczyk MD**

**e-mail: mzowczak@amp.edu.pl**

**Wojciech Żak MD**

**e-mail: wojzak@amp.edu.pl**

## **C O P Y R I G H T**

**All rights reserved. No part of this book may be reproduced in any form or by any electronic or mechanical means, including information storage and retrieval systems, without written permission from the Head of the Department of Clinical Biochemistry**

**PART I**  
**A guide to the course**

## Introduction to the Course of Laboratory Medicine

### Dear Students!

In the contemporary medicine an enormous progress is observed in the field of the understanding of diseases' pathogenesis and natural course. That makes it possible to draw up the new diagnostic and therapeutic methods. One of many diagnostic tools of crucial importance in the modern medicine is Laboratory Medicine. Laboratory tests are widely used to make the proper diagnosis, to estimate disease's advance as well as to monitor the therapy results. When performed in selected subjects as the screening tests they enable the early diagnosis of many diseases in the asymptomatic stage. For the other hand the clinical practice often shows ineffective use of laboratory tests which are ordered too frequently with no relation to the clinical situation generating artificial costs of health-care. The tests results are also often improperly interpreted leading to misdiagnosis what might be even harmful to a patient.

The aim of the Laboratory Medicine course is to get the practical skills of proper selection and interpretation of laboratory tests. The laboratory tests and the rules of their results interpretation are presented in relation to the patients' history and the physical examination mainly in the form of the clinical cases analysis. This way you'll get the ability how to match the lab tests with the given clinical picture.

The course consist of a few thematic blocks referring to the basic laboratory tests of hematology, nephrology, gastroenterology, cardiology, endocrinology, neoplastic disorders, disorders of lipid metabolism, water-electrolyte and acid-base balance and newly introduced concerning inflammation and infectious diseases. The separate exercise is devoted to the age-dependent characteristics of laboratory tests.

As the discussion of all topics listed above makes no sense without the basics of physiology, pathology and biochemistry, you are expected to be prepared for the classes following the guide you are reading. The guide consists of the information what should be reviewed before the exercise, what is the topic of the seminar and what are the abilities the student should possess after finishing it. "Review" consists of the outline of the seminar (in details) prepared by the leading teacher with all the slides, graphs and pictures presented during the seminar as well as the suggested readings.

The first part of each seminar is the discussion of the laboratory test in the relation to the physiology, pathology, biochemistry, clinical history and physical findings. This way your preparation to the seminar is ascertained. The theoretical part is followed by the analysis of the clinical cases related to the discussed topic. After the presentation of the history and the results of the physical examination you'll be asked for the propositions of laboratory tests which might be useful in solving the given clinical problem. The lab test results, differential diagnosis and diagnostic algorithms are all than carefully discussed.

After each two exercises with a given teacher there is a short test to be taken. The aim of the test is the repetition and the assessment of the previously got knowledge. As the test questions are formulated on the principles referring to the USMLE, it is an integral part of your preparation for the exam. To check the given problem understanding, you'll be asked not only to mark the best answer but also to explain briefly why you have chosen this one. After the test correct answers and emerging problems are discussed.

To get credit you are expected to be present on all the exercises (in the case of one justified absence a clinical case related to the missed exercise must be studied in written).

The course finishes with final exam. At least 50% correct answers is required to pass the test.

With any questions or doubts arising from the rules of the course performance, please call Waldemar Myszka MD ([wmyszka@amp.edu.pl](mailto:wmyszka@amp.edu.pl), phone + 48 501 492 055), who is assigned to serve you with any help.

Prof. Lech Torliński MD, PhD

**Department of Laboratory Medicine**  
**Schedule for GROUP A (20.11.2006 – 15.12.2006)**

Group	20 <sup>th</sup> of Nov	21 <sup>st</sup> of Nov	22 <sup>nd</sup> of Nov	23 <sup>rd</sup> of Nov	24 <sup>th</sup> of Nov	27 <sup>th</sup> of Nov	28 <sup>th</sup> of Nov	29 <sup>th</sup> of Nov	30 <sup>th</sup> of Nov	1 <sup>st</sup> of Dec	4 <sup>th</sup> of Dec	5 <sup>th</sup> of Dec	6 <sup>th</sup> of Dec	7 <sup>th</sup> of Dec	8 <sup>th</sup> of Dec	11 <sup>th</sup> of Dec	12 <sup>th</sup> of Dec	13 <sup>th</sup> of Dec	14 <sup>th</sup> of Dec	15 <sup>th</sup> of Dec
6	V	VI	III		IV	I	II		VII	VIII	IX	X			XIII	XI	XII			
7	VII	VIII				IX	X	I	II		XI	XII	V	III	IV	VI	XIII			
8	XII	XI	V		VII	VIII		III	VI	IV	I	II	IX		X	XIII				
9	IX	X	XI		XII		VII	VIII		XIII	V	VI	I	II		III	IV			
10	I	II	IX		X		XI	XII		V	III	IV	XIII		VI	VII	VIII			

FINAL EXAM

XX - classes     
  - day off

6	7	8	9	10
Dreisbach, Jeremiah	Walker, Travis	Rahman, Sakibur	Ashkar, Jameel	Rakoczy, Katherine
Chen , I-Cheng	Trelease, Shannon	Khabbaz, Omar	Chomicz, Grzegorz	Barnett, Robert
Weerdenburg, Kirsten	Vanderveelde, Gerry	Ketema, Mulugeta	Werpachowski, Jack	Dilmaghani-Tabriz, Darah
Yamani, Feisal	Salejee, Ismail	Saleh, Fahad	Plumptre, Adewale	
	Badger, Christopher	Latefi, Babak	Ogun, Oluwatobi	

*You'll be looked forward at the following places...*

EXERCISE		I	II	III	IV	V	VI	VII	VIII	IX	X	XI	XII	XIII	
<b>GROUP A</b>	<b>6</b>	Date	<b>27.11</b>	<b>28.11</b>	<b>22.11</b>	<b>24.11</b>	<b>20.11</b>	<b>21.11</b>	<b>30.11</b>	<b>1.12</b>	<b>4.12</b>	<b>5.12</b>	<b>11.12</b>	<b>12.12</b>	<b>8.12</b>
		Place	Dąbrowskiego room 903	Dąbrowskiego room 905	Dąbrowskiego room 905	Dąbrowskiego room 905	Dąbrowskiego room 905	Dąbrowskiego room 905	Collegium Chemicum	Dąbrowskiego room 912	Dąbrowskiego room 608	Dąbrowskiego room 608	Collegium Chemicum	Collegium Chemicum	Dąbrowskiego room 912
	<b>7</b>	Date	<b>29.11</b>	<b>30.11</b>	<b>7.12</b>	<b>8.12</b>	<b>6.12</b>	<b>11.12</b>	<b>20.11</b>	<b>21.11</b>	<b>27.11</b>	<b>28.11</b>	<b>4.12</b>	<b>5.12</b>	<b>12.12</b>
		Place	Dąbrowskiego room 912	Dąbrowskiego room 608	Dąbrowskiego room 412	Dąbrowskiego room 905	Dąbrowskiego room 905	Dąbrowskiego room 903	Collegium Chemicum	Collegium Chemicum	Dąbrowskiego room 608	Dąbrowskiego room 608	Collegium Chemicum	Collegium Chemicum	Dąbrowskiego room 912
	<b>8</b>	Date	<b>4.12</b>	<b>5.12</b>	<b>29.11</b>	<b>1.12</b>	<b>22.11</b>	<b>30.11</b>	<b>24.11</b>	<b>27.11</b>	<b>6.12</b>	<b>8.12</b>	<b>21.11</b>	<b>20.11</b>	<b>11.12</b>
		Place	Dąbrowskiego room 903	Dąbrowskiego room 412	Dąbrowskiego room 905	Dąbrowskiego room 905	Dąbrowskiego room 912	Collegium Chemicum	Collegium Chemicum	Dąbrowskiego room 905	Dąbrowskiego room 608	Dąbrowskiego room 608	Collegium Chemicum	Collegium Chemicum	Dąbrowskiego room 912
	<b>9</b>	Date	<b>6.12</b>	<b>7.12</b>	<b>11.12</b>	<b>12.12</b>	<b>4.12</b>	<b>5.12</b>	<b>28.11</b>	<b>29.11</b>	<b>20.11</b>	<b>21.11</b>	<b>22.11</b>	<b>24.11</b>	<b>1.12</b>
		Place	Dąbrowskiego room 912	Dąbrowskiego room 608	Dąbrowskiego room 905	Dąbrowskiego room 905	Dąbrowskiego room 912	Dąbrowskiego room 912	Collegium Chemicum	Collegium Chemicum	Dąbrowskiego room 608	Dąbrowskiego room 608	Collegium Chemicum	Collegium Chemicum	Dąbrowskiego room 608
	<b>10</b>	Date	<b>20.11</b>	<b>21.11</b>	<b>4.12</b>	<b>5.12</b>	<b>1.12</b>	<b>8.12</b>	<b>11.12</b>	<b>12.12</b>	<b>22.11</b>	<b>24.11</b>	<b>28.11</b>	<b>29.11</b>	<b>6.12</b>
		Place	Dąbrowskiego room 903	Dąbrowskiego room 912	Dąbrowskiego room 905	Dąbrowskiego room 905	Dąbrowskiego room 903	Dąbrowskiego room 903	Collegium Chemicum	Collegium Chemicum	Dąbrowskiego room 608	Dąbrowskiego room 608	Collegium Chemicum	Collegium Chemicum	Dąbrowskiego room 411

**Collegium Chemicum, Grunwaldzka 6, Department of Chemistry and Clinical Biochemistry, 2<sup>nd</sup> floor (via the passage through the students' reading-room)**

**Dąbrowskiego, Collegium Adama Wrzoska, Dąbrowskiego 79**



No. of exercise	List of topics/leading teachers' names/Contents		
I	<b>The usefulness of laboratory data in the differential diagnosis of anemia/</b> Wojciech Żak MD	4 hrs	4.00 – 7.00 p.m.
II	<b>Basic laboratory tests in the diagnosis and management of haemostatic failure/</b> Wojciech Żak MD	5 hrs	4.00 – 7.45 p.m.
III	<b>The evaluation of acid-base balance in clinical practice/</b> Waldemar Myszka MD	4 hrs	4.00 – 7.00 p.m.
IV	<b>Diagnostic approach to water-electrolyte disturbances/</b> Waldemar Myszka MD	5 hrs	4.00 – 7.45 p.m.
V	<b>Biochemical effects of neoplastic diseases/</b> Miłoslawa Zowczak-Drabarczyk MD	4 hrs	4.00 – 7.00 p.m.
VI	<b>Plasma proteins.</b> <b>Laboratory diagnosis of inflammation and infectious diseases /</b> Miłoslawa Zowczak-Drabarczyk MD	5 hrs	4.00 – 7.45 p.m.
VII	<b>Urinalysis and other laboratory procedures in the diagnosis of urinary tract disorders/</b> Dorota Formanowicz MD	3 hrs	4.00 – 6.15 p.m.
VIII	<b>Acute and chronic kidney failure.</b> <b>Clinical basics of haemodialysis/</b> Dorota Formanowicz MD	3 hrs	4.00 – 6.15 p.m.
IX	<b>The application of laboratory methods in the diagnosis and management of heart diseases/</b> Hanna Kara-Perz MD	4 hrs	4.00 – 7.00 p.m.
X	<b>Clinical enzymology and liver function disorders/</b> Hanna Kara-Perz MD	5 hrs	4.00 – 7.45 p.m.
XI	<b>The differential diagnosis of lipid metabolism disorders.</b> /Ewa Wysocka MD / Prof. Lech Torliński MD, PhD (Laboratory tests)	4 hrs (3 hrs)	4.00 – 7.00 p.m.
XII	<b>Laboratory tests in the diagnosis of hyper- and hypoglycemia /</b> Ewa Wysocka MD / Prof. Lech Torliński MD, PhD (Laboratory tests)	5 hrs (3 hrs)	4.00 – 7.45 p.m.
XIII	<b>Age-dependent characteristics of laboratory tests/</b> Sylvia Dziegielewska MD	3 hrs	4.00 – 6.15 p. m.

# SYLLABUS

## **EXERCISE I: The usefulness of laboratory data in the differential diagnosis of anemia**

**TEACHER'S NAME:** Wojciech Żak MD

**CONTENTS:** Exercise - 4 x 45 min. (4.00 – 7.00 p.m.)

**OBJECTIVE:** *After completion of this exercise you should be able to:*

- order a Complete Blood Count (CBC) correctly
- interpret any abnormal CBC result
- make use of a CBC as the first step in the differential diagnosis of anaemia
- choose effective laboratory tests to determine the cause of anemia

**REVISION:** *Since cases of micro-, normo- and macrocytic anemia will be analysed, revision and consideration of the following issues would be beneficial:*

- pathophysiological and morphological classification of anemias (according to MCV)
- general and specific symptoms and signs of anemias

## **EXERCISE II: Basic laboratory tests in the diagnosis and management of haemostatic failure**

**TEACHER'S NAME:** Wojciech Żak MD

**CONTENTS:** Exercise - 5 x 45 min. (4.00 – 7.45 p.m.)

**OBJECTIVE:** *After completion of this exercise you should be able to:*

- recognize the clinical conditions, where estimation of hemostasis is particularly indicated
- conduct such an estimation with the help of basic (screening) laboratory tests
- differentiate between primary and secondary hemostasis defect
- formulate a hypothesis concerning the cause of hemostatic failure according to its clinical presentation and the results of the screening lab tests
- decide the most cost-effective selection of further laboratory analyses to determine the differential diagnosis of the commonest hemorrhagic diatheses
- monitor the anticoagulant treatment

**REVISION:** *Since a case study will form the background to discussing the diagnostic algorithms, revision of the following issues would be useful:*

- physiology of hemostasis and the diagnostic significance of basic laboratory tests aiming to its estimation (BT, PT, APTT, TT)
- clinical symptoms and signs of the hemorrhagic diatheses
- causes of thrombocytopenia

### EXERCISE III: The evaluation of acid-base balance in clinical practice

**TEACHER'S NAME:** Waldemar Myszka MD

**CONTENTS:** Exercise – 4 x 45 min. (4.00 – 7.00 p.m.)

**OBJECTIVE:** *After completion of this exercise you should be able to:*

- properly evaluate results of blood gases analysis
- differentiate between simple and mixed acid-base balance disorders on the base of clinical and laboratory data
- monitor treatment of acid-base balance disorders

**REVISION:** *Clinical cases of patients with metabolic and respiratory acidosis and alkalosis will be considered, so revision of the following problems is advisable:*

- the chemical and physiologic bases of:
  - hydrogen ion concentration (pH), buffering, carbonic acid – bicarbonate buffer system, Henderson-Hasselbalch equation, anion gap, osmotic gap,
  - renal contribution to hydrogen ion balance: bicarbonate reabsorption, acid excretion, titratable acidity,
  - carbon dioxide excretion
- normal values of laboratory acid-base balance indicators:
  - pH, pCO<sub>2</sub>, pO<sub>2</sub>, HCO<sub>3</sub><sup>-</sup>, BE, O<sub>2</sub> sat.

### EXERCISE IV: Diagnostic approach to water – electrolyte disturbances

**TEACHER'S NAME:** Waldemar Myszka MD

**CONTENTS:** Exercise - 5 x 45 min. (4.00 – 7.45 p.m.)

**OBJECTIVE:** *After completion of this exercise you should be able to:*

- obtain useful data from the clinical history and physical examination followed by properly selected laboratory tests
- interpret abnormal results of plasma electrolyte concentration in particular clinical situations
- properly replace water and electrolyte losses
- choose laboratory tests for monitoring treatment of water-electrolyte disorders

**REVISION:** *As the clinical cases of patients presenting with dehydration, overhydration (oedema), hypo- and hypernatremia and hypo- and hyperkalemia will be discussed, one should review the following issues:*

- definition of terms: osmolality, effective osmolality, isotonic, hypertonic, and hypotonic solutions, hydrostatic pressure, osmotic pressure, oncotic pressure
- water-sodium balance
- potassium balance

## **EXERCISE V: Biochemical effects of neoplastic diseases**

**TEACHER'S NAME:** Miłoslawa Zowczak-Drabarczyk MD

**CONTENTS:** Exercise - 5 x 45 min. (4.00 – 7.45 p.m.)

**OBJECTIVE:** *After completion of this exercise you should be able to:*

- suspect a neoplastic process when observing various abnormalities in basic lab parameters
- make use of tumor markers in the diagnosis and management of neoplastic disease

**REVISION:** *As we shall be studying a number of clinical cases prepare, please, short revision on the following tumor markers:*

- CEA
- AFP
- PSA
- CA 125
- CA 19-9
- CA 15-3
- beta-hCG

## **EXERCISE VI: Plasma proteins and laboratory diagnosis of inflammation and infectious diseases**

**TEACHER'S NAME:** Miłoslawa Zowczak-Drabarczyk MD

**CONTENTS:** Exercise - 4 x 45 min. (4.00 – 7.00 p.m.)

**OBJECTIVE:** *After completion of this exercise you should be able to:*

- order suitable lab tests and interpret their results when
  - observing clinical manifestations of disorders resulting in serum and/or urine proteins abnormalities
  - suspecting inflammatory process of either infective (bacterial, viral) or non infective etiology

**REVISION:** *To work on an actual case study, please revise the following:*

- hypo- and hyperproteinemias
- proteinuria
- interpretation of serum protein electrophoresis abnormalities
- lab tests for identification of monoclonal protein
- lab tests for identification of specific proteins
- innate and adaptive immunity components and mechanisms
- inflammatory process and its mediators
- complement components-useful analysis
- cytokines-useful analysis
- positive and negative acute phase proteins
- interpretation of ESR changes
- CBC changes due to infection/inflammation
- interpretation of increased CRP concentration in various inflammatory conditions
- lab tests for differentiation between infective and non infective inflammation, and between bacterial and viral ones.

## **EXERCISE VII: Urinalysis and other laboratory procedures in the diseases of urinary tract**

**TEACHER'S NAME:** Dorota Formanowicz MD

**CONTENTS:** Exercise - 3 x 45 min. (4.00 – 6.15 p.m.)

**OBJECTIVE:** *After completion of this exercise you should be able to:*

- interpret the results of urine and blood analyses used in the assessment of renal function and the diagnosis of selected diseases of the urinary system

**REVISION:** *For this exercise revision of the following issues would be useful:*

- glomerular filtration rate
- regulation of water- electrolyte and acid-base balance
- mechanisms of urine concentration and dilution

**Attention please!** Before this exercise (in the morning after minimally 8 hrs fasting) you are asked to deliver your urine samples to the laboratory (Collegium Chemicum, Grunwaldzka 6). During the first part of this exercise urinalysis (urine: pH, specific gravity, glucose, bilirubin, ketones, protein (microalbuminuria), nitrate, blood and leukocytes) of your urine samples will be performed.

**Please take white coats.**

## **EXERCISE VIII: Kidney failure and clinical basics of dialysis**

**TEACHER'S NAME:** Dorota Formanowicz MD

**CONTENTS:** Exercise - 3 x 45 min. (4.00 – 6.15 p.m.)

**OBJECTIVE:** *After completion of this exercise you should be able to:*

- differentiate between prerenal, renal and postrenal acute renal failure
- differentiate between acute renal failure and chronic kidney disease
- monitor progression of chronic kidney disease
- choose laboratory tests for monitoring state of uremic patient and interpret abnormal results of selected laboratory tests of blood and urine
- list indications and contraindications for dialysis treatment

**REVISION:** *For this exercise revision of the following issues would be useful:*

- glomerular filtration rate
- regulation of water-electrolyte and acid-base balance
- mechanisms of urine concentration and dilution
- regulation of calcium-phosphate balance

**EXERCISE IX: The application of laboratory methods in the diagnosis and management of ischemic heart disease**

**TEACHER'S NAME:** Hanna Kara-Perz MD

**CONTENTS:** Exercise - 4 x 45 min. (4.00 – 7.00 p.m.)

**OBJECTIVE:** *After completion of this exercise you should be able to:*

- select and interpret the laboratory tests indicated in a patient with suspected myocardial infarction
- make a total assessment of the risk factors of ischemic heart disease

**REVISION:** *Recollection of information concerning the following issues would be beneficial:*

- myocardial oxygen demand and supply
- clinical manifestations of myocardial ischemia

**EXERCISE X: Clinical enzymology and liver function disorders diagnosis**

**TEACHER'S NAME:** Hanna Kara-Perz MD

**CONTENTS:** Exercise - 5 x 45 min. (4.00 – 7.45 p.m.)

**OBJECTIVE:** *After completion of this exercise you should be able to:*

- order lab tests reasonably and interpret their results when:
  - suspecting liver disorder

**REVISION:** *To work on an actual case study, please revise the following:*

- serum conjugated and unconjugated bilirubin
- bilirubin and urobilinogen in urine
- alkaline phosphatase (ALP)
- lactic dehydrogenase (LDH)
- gamma GT (GGTP)
- prothrombin time (PT)
- serum protein profile
- acute phase proteins
- blood ammonia

## EXERCISE XI: The differential diagnosis of disorders of lipid metabolism

TEACHERS' NAMES: Ewa Wysocka MD/ Prof. Lech Torliński MD, PhD

CONTENTS: Exercise - 5 x 45 min. (4.00-7.45 p.m.)  
Laboratory – 2 x 45 min.

OBJECTIVE: *After completion of this exercise you should be able to:*

- diagnose primary and secondary hyperlipoproteinemia
- order the correct biochemical tests for the primary and secondary prevention of Ischemic Heart Disease (IHD)
- assess the lipid risk factors for IHD

REPETITION: *For the clinical diagnosis and laboratory monitoring of hyperlipoproteinemia in the prevention of IHD, please revise:*

- the structure and function of lipoproteins,
- lipoprotein metabolism,
- the pathogenesis of atherosclerosis,
- the risk factors for the development of IHD.

**Attention please!** During this exercise concentrations of some lipid parameters (triglycerides, total cholesterol, HDL-cholesterol and LDL-cholesterol) in your blood will be determined and your risk of coronary artery disease according to Framingham system will be calculated.

**Please take white coats.**

## EXERCISE XII: Laboratory tests in the diagnosis of hyper- and hypoglycemia

TEACHERS' NAMES: Ewa Wysocka MD/ Prof. Lech Torliński MD, PhD

CONTENTS: Exercise - 5 x 45 min. (4.00-7.45 p.m.)  
Laboratory – 4 x 45 min.

OBJECTIVE: *After completion of this exercise you should be able to:*

- recognize the risk factors for the development of diabetes mellitus (especially type 2)
- diagnose diabetic and prediabetic states
- monitor diabetes mellitus biochemically
- recognize acute and late diabetic complications
- diagnose hypoglycemia

REVISION: *To achieve the aim of this exercise, please revise:*

- carbohydrates' metabolism and its hormonal regulation,
- pathobiochemistry of diabetes mellitus and its complications ( acute, late: macro- and microangiopathy),
- the insulin resistance syndrome – syndrome X,
- classification of hyperglycemic states,
- categories of hypoglycemia.

**Attention please!** During the first part of this exercise you will have an opportunity to estimate your own blood glucose concentration.

**Please take white coats.**

**EXERCISE XIII: Age-dependent characteristics of laboratory tests**

**TEACHER'S NAME:** Sylwia Dzięgielewska MD

**CONTENTS:** Exercise - 3 x 45 min. (4.00 – 6.15 p.m.)

**OBJECTIVE:** *After completion of this exercise you should be able to:*

- indicate how biochemical and physiological consequences of ageing are reflected in lab tests,
- differentiate between age-dependent “abnormal” tests results and those which may actually indicate the disease,
- select the most effective tests in the differential diagnosis of symptoms and signs: are they age- or disease-related?
- choose lab tests which are particularly useful in screening and monitoring age-related diseases,
- use laboratory tests in the determination of 6 month or less medical prognosis.

**REVISION:** *Since a number of clinical cases will be analyzed, please revise:*

- biochemical and physiological changes of ageing

**FINAL EXAM**

**Attention please!**

You will be not allowed to take the exam  
without your credit books and examination cards.



**PART II**  
**Review of Laboratory Medicine**

## Clinical laboratory tests – reference range

– Prof. Lech Torliński MD, PhD

HEMATOLOGIC	Conventional Units	SI Units
<b>Erythrocyte count (RBC):</b>	Male: 4.5-6.0 million/mm <sup>3</sup> Female: 4.0-5.5 million/mm <sup>3</sup>	4.5-6.0x10 <sup>12</sup> /L 4.0-5.5x10 <sup>12</sup> /L
<b>Erythrocyte sedimentation rate (ESR):</b>	Male: 0-15 mm/h Female: 0-20 mm/h	
<b>Hematocrit (HCT, PCV, Packed Cell Volume):</b>	Male: 40-54 % Female: 37-47 %	0.40-0.54 L/L 0.37-0.47 L/L
<b>Hemoglobin A<sub>1C</sub></b> < 6 %		
<b>Hemoglobin, blood (HGB, HB):</b>	Male: 13.5-17.5 g/dL, Female: 12-16 g/dL	8.38-10.86 mmol(HbFe)/L 7.45-9.93 mmol(HbFe)/L
<b>Hemoglobin, plasma:</b>	1-4 mg/dL	
<b>Haptoglobin:</b>	100-250 mg/dL	
<b>Leukocyte count (WBC):</b>	4-10 thousand/mm <sup>3</sup>	4.0-10.0x10 <sup>9</sup> /L
<b>Leukocyte-differential:</b>		
band neutrophils (Bands)	3-5 %	0.03-0.05
segmented neutrophils (Segs)	40-65 %	0.40-0.65
monocytes (Mono)	3-7 %	0.03-0.07
eosinophils (Eosi)	1-3 %	0.01-0.03
basophils (Baso)	0-1 %	0.00-0.01
lymphocytes (Lymph)	20-45 %	0.20-0.45
<b>Mean corpuscular hemoglobin (MCH):</b>	27-32 pg/cell	
<b>Mean corp.hemogl.concentration (MCHC):</b>	31-36 g/dL	
<b>Mean corpuscular volume (MCV):</b>	80-100 fL	
<b>RBC volume distribution width (RDW):</b>	11.5-14.5 %	
<b>Platelet count (PLT):</b>	140-400 thousand/mm <sup>3</sup>	140-400 x 10 <sup>9</sup> /L
<b>Reticulocyte count:</b>		
<b>Relative reticulocyte count (RET):</b>	0.5-2.0 % RBC	
<b>Absolute reticulocyte count (ARC):</b>	25-75 x 10 <sup>9</sup> /L	
<b>Corrected reticulocyte count (CRC):</b>	< 2 %	
	CRC% = RET% (anemia) x [HCT%(anemia) / HCT 45%]	
<b>Reticulocyte production index (RPI):</b>	> 3	
	RPI = CRC% / maturationtime	

**Lymphocyte (diff):** B cell ..... 1-25 %  
 Total T, CD3 ..... 60-87 %  
 Helper, CD4 ..... 30-55 %  
 Suppr, CD8 ..... 10-40 %  
 H : S, CD4/CD8 ..... 0.8-3.0

**Bleeding time (BT):** 2 – 7 min

**Partial thromboplastin time activated (APTT):** 25-40 sec

**Prothrombin time (PT):** 11-15 sec

**INR** 0.9-1.1

**Thrombin time (TT ):** 10-14 sec

**Fibrinogen:** 200-400 mg/dL

**Beta-2 microglobulin:** < 2.0 mg/L

**Volume plasma:** Male: 25-43 mL/kg, Female: 28-45 mL/kg

**Volume red cell:** Male: 20-36 mL/kg, Female: 19-31 ml/kg

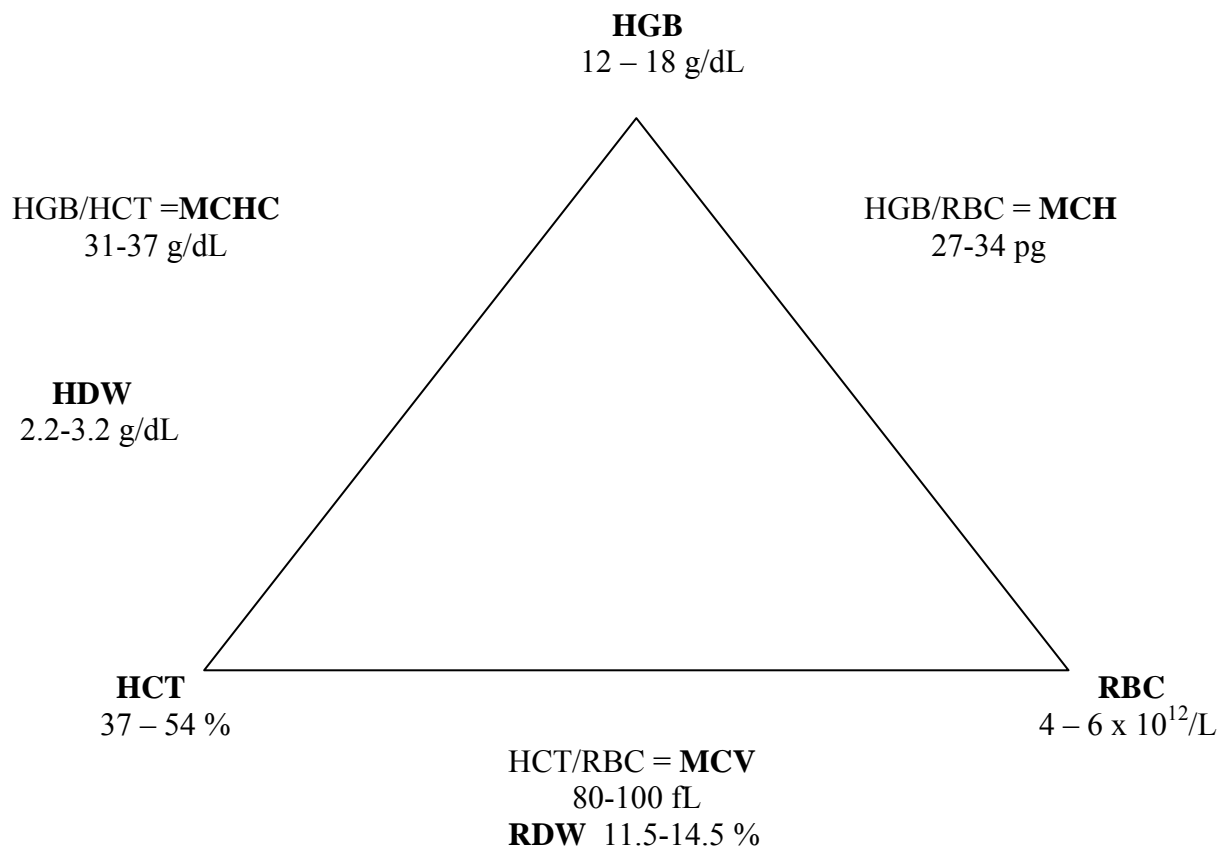

**RBC x 3 = HGB**

**HCT : 9 = RBC**

**HGB x 3 = HCT**

## HYPERCHOLESTEROLEMIA

$$\text{Cholesterol mg/dL} \times 0.0259 = \text{mmol/L}$$

Total Chol. > 190 mg/dL	> 4.93 mmol/L
LDL Chol. > 115 mg/dL	> 2.98 mmol/L
TG < 200 mg/dL	< 2.28 mmol/L

HLP phenotypes:

type II a :	high Cholesterol	high LDL
type VI :	high Cholesterol	high HDL

## HYPERTRIGLYCERIDEMIA

$$\text{Triglycerides (TG) mg/dL} \times 0.0114 = \text{mmol/L}$$

TG > 200 mg/dL	> 2.28 mmol/L
Total Chol. < 190 mg/dL	< 4.93 mmol/L
LDL Chol. < 115 mg/dL	< 2.98 mmol/L

HLP phenotypes:

type I :	high TG	high Chylomicrons
type IV :	high TG	high VLDL
type V :	high TG	high Chylomicrons and high VLDL

## THE FRIEDEWALD FORMULA

$$\text{LDL Chol} = \text{T.Chol} - \text{HDL Chol} - \text{TG}/5$$

## MIXED HYPERLIPOPROTEINEMIA

Total Chol. > 190 mg/dL	> 4.93 mmol/L
LDL Chol. > 115 mg/dL	> 2.98 mmol/L
TG > 200 mg/dL	> 2.28 mmol/L

HLP phenotypes:

type IIb :	high Cholesterol and high TG	high LDL and high VLDL
type III :	high Chol. and high TG	high VLDL with beta mobility

## HIGH RISK OF CVD

**TG** > 200 mg/dL  
**T.Chol** > 190 mg/dL  
**LDL Chol** > 115 mg/dL  
**HDL Chol** < 35 mg/dL  
**T.Chol / HDL Chol** > 3  
**[HDL+ VLDL+ LDL] / HDL** > 3  
**Lp(a)** > 30 mg/dL  
**Apolipoprotein A** < 2.43 g/L  
**Apolipoprotein AI** < 1.15 g/L  
**Apolipoprotein B<sub>100</sub>** > 1.6 g/L Male  
> 1.5 g/L Female  
**Homocysteine** > 16 µmol/L

## BIOCHEMICAL MARKERS OF AMI

MARKER	TIME OF FIRST INCREASE	PEAK	DURATION OF INCREASE
Myoglobin	1-3 h	~6h	12-24 h
CK-MB mass	3-4 h	~14h	24-46 h
cTn T	3-4 h	~18 h	10-14 days
cTn I	4-6 h	~19 h	4-7 days

## NORMAL FASTING PLASMA GLUCOSE

60-110 mg/dL                      3.33-6.10 mmol/L

## NORMAL PLASMA GLUCOSE

2 hours after OGTT              < 140 mg/dL

## NORMAL BLOOD GAS VALUES

<b>pH</b>	arterial .....	7.37 – 7.43
	capillary .....	7.36 – 7.42
	venous .....	7.32 – 7.38
<b>pCO<sub>2</sub></b>	arterial .....	36 – 44 mm Hg
	capillary .....	35 – 45 mm Hg
	venous .....	42 – 50 mmHg
<b>pO<sub>2</sub></b>	arterial .....	74 – 108 mm Hg
	capillary .....	65 – 95 mmHg
	venous .....	~ 40 mm Hg
<b>SatO<sub>2</sub></b>	arterial .....	92 – 96 %
	capillary .....	70 – 95 %
	venous .....	54 – 69 %
<b>[HCO<sub>3</sub><sup>-</sup>]</b>	arterial .....	22 – 26 mmol/L
	capillary .....	21 – 27 mmol/L
	venous .....	23 – 27 mmol/L

<b>Normal range of base excess in arterial</b>	-2.5 to +2.5 mmol/L
<b>Negative base excess</b>	-BE < -2.5 mmol/L
<b>Positive base excess</b>	+BE > +2.5 mmol/L

## ACIDOSIS AND ALKALOSIS

	pH	BE mmol/L	PCO <sub>2</sub> mm Hg	corrected [HCO <sub>3</sub> <sup>-</sup> ] mmol/L
<b>respiratory ACIDOSIS</b>	< 7.36	> +2.5	> 45	> 24
uncompensated	low		high	
compensation				high
.....				
<b>metabolic ACIDOSIS</b>	< 7.36	< -2.5	< 35	< 24
uncompensated	low			low
compensation			low	
.....				
<b>respiratory ALKALOSIS</b>	> 7.42	< -2.5	< 35	< 24
uncompensated	high		low	
compensation				low
.....				
<b>metabolic ALKALOSIS</b>	> 7.42	> +2.5	> 45	> 24
uncompensated	high			high
compensation			high	
.....				

## BODY WATER

**Total body water:** M. ~60% of body mass  
F. ~50% of body mass

**Proportion of total body water:** intracellular, two thirds  
extracellular, one thirds

**Normal osmolality** 275-295 mOsm/kg H<sub>2</sub>O

**Anion gap** 8-16 mmol/L  $AG = [Na^+] - \{[HCO_3^-] + [Cl^-]\}$

**Corrected  $[HCO_3^-]$**  = measured  $[HCO_3^-]$  + (anion gap - 12)

## ANIONS IN SERUM

**Chloride (Cl<sup>-</sup>)** 102 mEq/L, 102 mmol/L, 96-106 mmol/L

**Bicarbonate (HCO<sub>3</sub><sup>-</sup>)** 26 mEq/L, 26 mmol/L, 24-28 mmol/L

**Proteins** 15 mEq/L, 70 g/L

**Organic acids** 5 mEq/L

**Phosphates (HPO<sub>4</sub><sup>2-</sup>)** 2 mEq/L, 1 mmol/L, 2.5-5.0 mg/dL

**Symptoms of hypophosphatemia (phosphate < 2.5 mg/dL) :**

*weakness, lethargy, irritability, depressed cardiac and respiratory function, hypotension, cardiac arrhythmias, red and white cell dysfunction, skeletal demineralization*

**Symptoms of hyperphosphatemia (phosphate > 5 mg/dL):**

*pruritis; otherwise, symptoms are unremarkable*

**Sulphates (SO<sub>4</sub><sup>2-</sup>)** 1 mEq/L, 0.5 mmol/L

## CATIONS IN SERUM

**Sodium (Na<sup>+</sup>)** 142 mEq/L, 135-145 mEq/L, 142 mmol/L

**Symptoms of hyponatremia ( sodium < 135 mEq/L):**

*confusion, lethargy, stupor, coma, nausea, vomiting, headache, irritability, muscle twitches, seizures (usually when hyponatremia develops rapidly)*

**Symptoms of hypernatremia ( sodium > 145 mEq/L):**

*lethargy, confusion, restlessness, seizures, coma, hyperreflexia, spasticity (neurologic symptoms are due to dehydration of brain cells)*

**Potassium (K<sup>+</sup>)** 5 mEq/L, 3.5-5 mEq/L, 5 mmol/L

**Symptoms of hypokalemia (potassium < 3.5 mEq/L):**

*neuromuscular (muscle weakness, paralysis, rhabdomyolysis, hyporeflexia), gastrointestinal (paralytic ileus), renal (polyuria, polydipsia, secondary decreased concentrating ability), cardiac (ECG findings include T-wave flattening and inversion, U-wave and ST segment depression. Hypokalemia enhances cardiac toxicity of digitalis)*

**Symptoms of hyperkalemia (potassium > 5 mEq/L):**

*weakness, paresthesias, flaccid paralysis, ventricular fibrillation, cardiac arrest*

**Calcium (Ca)** 5 mEq/L, 2.5 mmol/L, 8.5-10.5 mg/dL

**Calcium ionized (Ca<sup>2+</sup>):** 1.05-1.30 mmol/L

**Symptoms of hypocalcemia** (calcium < 8.5 mg/dL):

cardiovascular (hypotension, bradycardia, asystole, impaired contractility, QT prolongation and T-wave inversion on ECG, digitalis insensitivity), respiratory (bronchospasm and laryngeal spasm), neuromuscular (weakness, paresthesias, tetany, muscle spasm, Chvostek's and Trousseau's signs, hyperreflexia and seizures), psychiatric (anxiety, depression, irritability, confusion, dementia and psychosis)

**Symptoms of hypercalcemia** (calcium > 10.5 mg/dL):

also known as "stones, bones, groans and psychiatric overtones, cardiovascular (hypertension, bradycardia, first-degree AV block, increased repolarization, shortened QT interval), gastrointestinal (constipation, anorexia, nausea and vomiting, peptic ulcer disease, pancreatitis), renal (polyuria and polydipsia, nocturia, renal insufficiency, nephrolithiasis), musculoskeletal (weakness, myopathy, osteoporosis, bone pain), neurologic (decreased concentration, depression, confusion, psychosis, coma), other (pruritus, metastatic calcification)

**Magnesium (Mg<sup>2+</sup>)** 2 mEq/L, 1 mmol/L 1.8-2.3 mg/dL

**Symptoms of hypomagnesemia** (magnesium < 1.8 mg/dL):

cardiovascular (arrhythmias, e.g. atrial fibrillation and torsades de pointes, prolonged PR and QT intervals, T-wave flattening), neuromuscular (weakness, seizures, delirium, coma, hyperreflexia, fasciculations, Chvostek's and Trousseau's signs)

**Symptoms of hypermagnesemia** (magnesium > 2.3 mg/dL):

respiratory (respiratory depression, apnea), cardiovascular (hypotension, cardiac arrest, ECG findings : prolonged QRS complexes and QT intervals, heart block, peaked T waves), gastrointestinal (nausea and vomiting), neuromuscular (paresthesias, somnolence, confusion, coma, hypereflexia, paralysis, apnea)

## CLICAL CHEMISTRY, serum

<b>BUN</b>	8 - 25 mg/dL	
<b>Creatinine</b>	0.5 - 1.5 mg/dL	
<b>Glucose</b>	60 - 110 mg/dL	3.33 - 6.10
<b>Uric acid</b>	2.4 - 7.5 mg/dL	mmol/L
<b>Total protein</b>	6 - 8 g/dL	
<b>Albumin</b>	3.4 - 5.4 g/dL	
<b>Globulin</b>	2.3 - 3.5 g/dL	
<b>Total bilirubin</b>	0.2 - 1.5 mg/dL	
<b>Direct bilirubin</b>	0.0 - 0.3 mg/dL	3.4 - 25.5 µmol/L
<b>GOT, AST</b>	0 - 40 U/L	
<b>GPT, ALT</b>	0 - 40 U/L	
<b>GGTP</b>	10 - 50 U/L	
<b>LDH</b>	50 - 240 U/L	
<b>CK</b>	5 - 200 U/Dl	
<b>Iron</b>	50 - 160 µg/Dl	
<b>TIBC</b>	240 - 425 µg/dL	
<b>Iron % Sat</b>	20 - 55 %	
<b>Ferritin</b>	30 - 250 ng/mL	30 - 250 mg/L



## URINE EXAMINATION

<b>MICROALBUMINURIA</b>	30 - 300 mg/day
<b>ALBUMINURIA</b>	> 300 mg/day
<b>PROTEINURIA</b>	1 – 3 g/day
<b>Creatinine</b>	0.75-1.5 g/day
<b>Albumin : creatinine (A : C)</b>	30-300 mg alb/g crea



# ANEMIA



=  
*a significant reduction in the red cell mass  
and  
a corresponding decrease in the oxygen carrying capacity of the blood.*

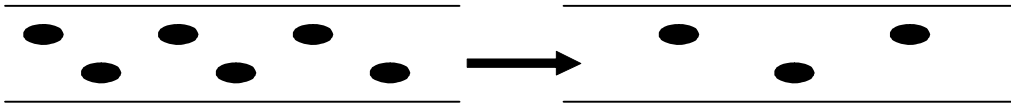

Since normally blood volume is maintained at a nearly constant level  
it entails a **decrease** of some peripheral blood values,  
(components of the CBC):

**RBC** (red blood cell count / unit of the whole blood volume)  
**HGB** (mass of hemoglobin / unit of the whole blood volume)  
= hemoglobin concentration  
**HCT** (volume of the red cells / unit of the whole blood volume) } ↓



**BUT**

**RBC** } ↓  
**HGB** }  
**HCT** }  
- not always reflects a real reduction  
in the red cell mass  
(anemia)  
- it also happens only due to an expanded blood volume  
(‘pseudoanemia’, e. g. pregnancy, congestive heart failure)

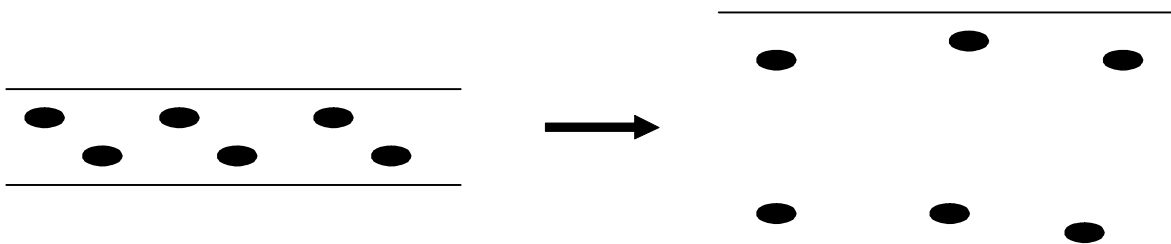

On the other hand

- a real anemia not necessarily presents  
with a simultaneous decrease of all these values (RBC, HGB, HCT)  
particularly at the early stages of its development

e.g. iron deficiency  
(disturbed hemoglobin synthesis makes red cells smaller,  
but – at least at the beginning – without a significant affect on their number)

### iron deficiency (early stage)

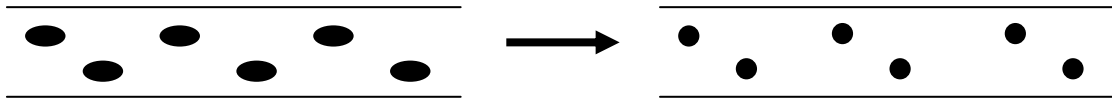

RBC     N

HGB     ↓

HCT     ↓

## CONCLUSION

**To diagnose an anemia one must:**

**1. find a significant decrease of at least 2 of these 3  
basic red cell system values in the CBC (RBC, HGB, HCT)**

(below the lower normal limit for patient's age and sex)

**2. exclude an expanded blood volume as a cause of such a decrease**

(particularly if it is mild an the only abnormality in the CBC)

## Major components of the CBC

(obtained by electronic hematological counters)

+

### and average ranges of reference (normal) values for adults

<u>Parameter(s)</u>		<u>reflecting status of the red blood cell system</u>		
	<u>Units</u>	<u>Females</u>	<u>Common</u>	<u>Males</u>
<b>RBC</b>	(x 10 <sup>12</sup> /L or T/L)	<b>4,0 - 5,5</b>		<b>4,5 - 6,0</b>
<b>HGB</b>	g/dL	<b>12 - 16</b>		<b>14 - 18</b>
<b>HCT</b>	(L/L or %)	<b>0,37 - 0,47</b>		<b>0,40 - 0,54</b>
<b>MCV</b> (Mean Corpuscular Volume)	fL (x 10 <sup>-15</sup> L)		<b>80 - 100</b>	
<b>RDW</b> (Red blood cell Distribution Width)	(%)		<b>11,5 - 14,5 (&lt;15)</b>	
<b>MCH</b> (Mean Corpuscular Hemoglobin)	pg (x 10 <sup>-12</sup> g)		<b>27 - 32</b>	
<b>MCHC</b> (Mean Corpuscular Hemoglobin Concentration)	g/dL		<b>32 - 37</b>	

**Reticulocyte Count** (absolute - provided only by the newest generation of hematological counters;  
- if not and needed -

an additional order is required to get a relative one by the manual method)

- Relative (% - of RBC) **0,5 - 1,5**
- Absolute (x 10<sup>9</sup>/L or G/L) **30 - 70**

#### reflecting status of the white blood cell system

**WBC** (x 10<sup>9</sup>/L or G/L) **4,0 - 10**  
(white blood cell count)

**Usually hematological counters present also the percentage of some WBC populations;  
to evaluate more accurately all of them the peripheral blood smear is required and the references are given below:**

<b>band neutrophils</b>	(% of WBC)	<b>1 - 5</b>
<b>segmented neutrophils</b>	(% of WBC)	<b>40 - 70</b>
<b>lymphocytes</b>	(% of WBC)	<b>20 - 45</b>
<b>monocytes</b>	(% of WBC)	<b>3 - 8</b>
<b>eosinophils</b>	(% of WBC)	<b>1 - 5</b>
<b>basophils</b>	(% of WBC)	<b>0 - 1</b>

#### reflecting status of the platelets

**PLT** (x 10<sup>9</sup>/L or G/L) **140 - 400**  
(platelet count)

The remainder platelet parameters (MPV, PDW, PCT)  
are of less diagnostic significance in everyday clinical practice!

# Major steps of analysis of CBC results in the diagnosis of anemia

## I. Is the patient really anemic?



*check the basic parameters  
of the red blood cell system  
(see: previous pages)*

**RBC, HGB, HCT**

## II. What kind of anemia is it morphologically?



*check the red blood cell indices*

1. MCV (micro-, normo-, macrocytic)
2. RDW (anisocytic or not)
3. MCH + MCHC (hypo-, normo-, hyperchromic)

## III. Is the pathology affecting only red blood cell system?



*check the parameters referring to remainder  
corpuscular elements of the blood*

1. WBC + % of different WBC populations
2. PLT

## IV. Confront the CBC results with the clinical picture

## V. Select the most effective laboratory procedures to find the cause of anemia

*The most important initial step in the differential diagnosis of anemia  
indicating directions of farther necessary investigations  
is its morphological classification according to red blood cell indices,  
with outstanding significance of*

**MCV**

(discussed in details on seminar)

**ANEMIA**  
with  
**MCV: < 80 fl**  
↓  
**microcytic anemia**

Since more than 90% of erythrocyte volume is fulfilled with **hemoglobin**  
it suggests **a defect in hemoglobin synthesis**

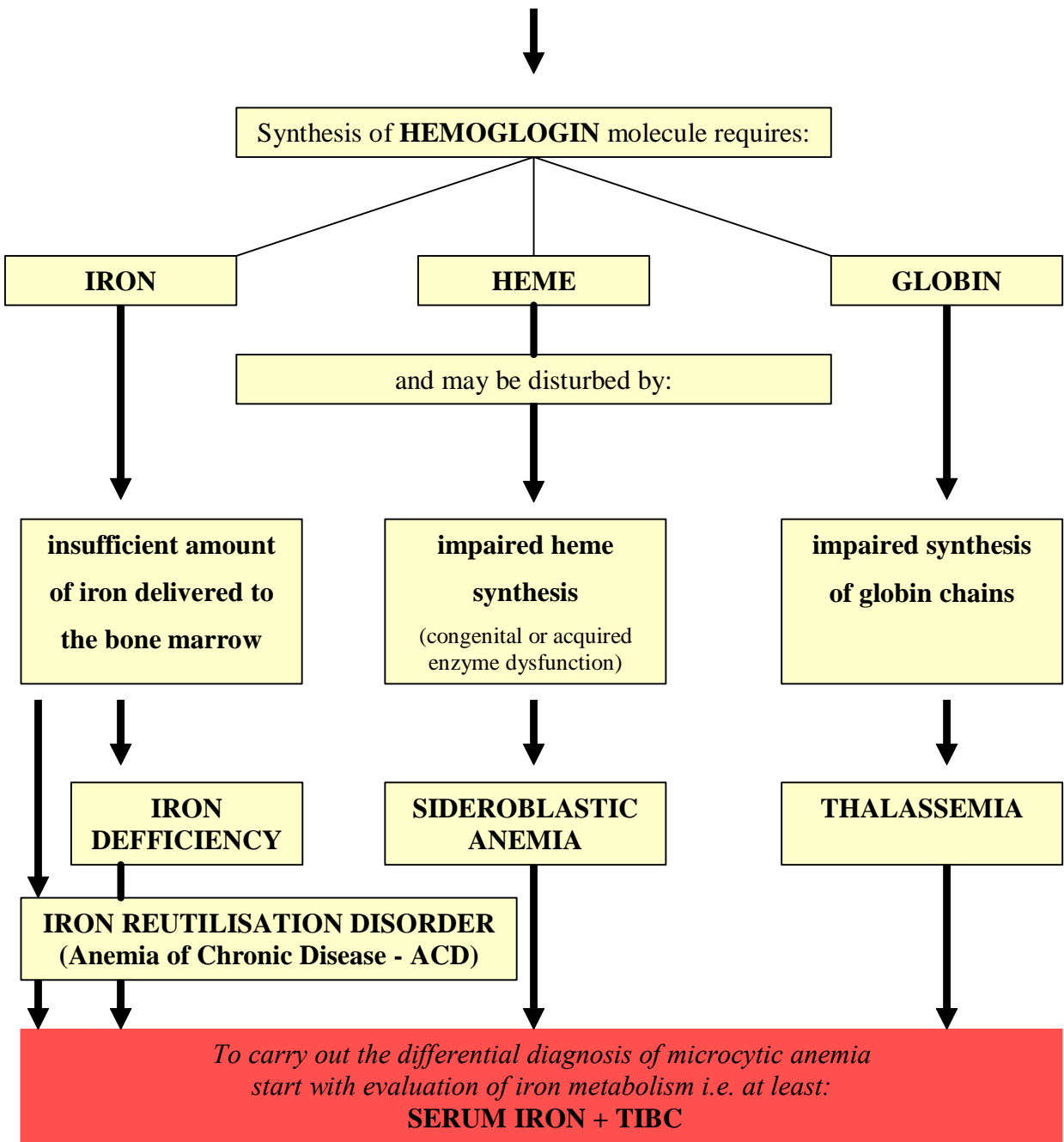
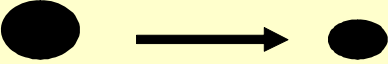

**ANEMIA**  
with  
**MCV: 80 – 100 fl**  
↓  
**normocytic anemia**  
(usually also normochromic: MCH, MCHC = N)

Is bone marrow responding to reduced red blood cell mass  
by enhanced erythropoietic activity?  
(is anemia of central or peripheral origin?)

**RETICULOCYTE COUNT**  
(absolute or relative-corrected)

**NORMAL OR DECREASED**

**ELEVATED**

Associated  
leukocyte and platelet  
abnormalities?

Associated evidences  
(clinical and laboratory)  
for hemolysis?

YES

NO

NO

YES

**Bone marrow  
disease, e.g.:**

- aplasia
- fibrosis
- malignancy
- infiltration
- myelodysplasia

**Systemic disease (symptomatic anemia)  
affecting course of erythropoiesis by:**

**Decreased release  
of erythropoiesis  
activators, e.g.:**

- uremia
- hypothyroidism

**Increased release  
of erythropoiesis  
inhibitors, e.g.:**

- anemia of chronic  
disease

**Acute  
blood loss**

**Hemolytic  
anemia**

Look for the cause:  
**BONE MARROW  
EXAMINATION**

Look for the specific laboratory features  
of clinically suspected systemic disease

The cause is  
usually obvious  
from the  
clinical findings

Look for the  
cause  
beginning  
from  
**BLOOD  
SMEAR**



**ANEMIA**  
with  
**MCV: > 100 fl**  
↓  
**macrocytic anemia**

*Is blood film suggestive of megaloblastic anemia?*

NO ↓

*Is anything suggestive of megaloblastic anemia?*

1. *clinical picture*
2. *CBC*
3. *biochemical assays*

YES →

YES ↓

Consider:

**BONE MARROW EXAMINATION**

NO ↓

**Non-megaloblastic**  
(secondary macrocytic)  
**anemia**

- alcohol, drugs
- liver disease
- hypothyroidism
- reticulocytosis

**Megaloblastic**  
(primary macrocytic)  
**anemia**

- history and clinical features usually indicate the likely cause

Follow the normocytic pathway and look for specific laboratory features of clinically suspected systemic disease

**NORMAL**

- drug induced
- inborn metabolic errors
- myelodysplastic syndrome

**SERUM B<sub>12</sub> AND SERUM FOLATE and RED CELL ANALYSIS**

**FOLATE DEFICIENCY**

**B12 DEFICIENCY**

**ESTABLISH CAUSE**

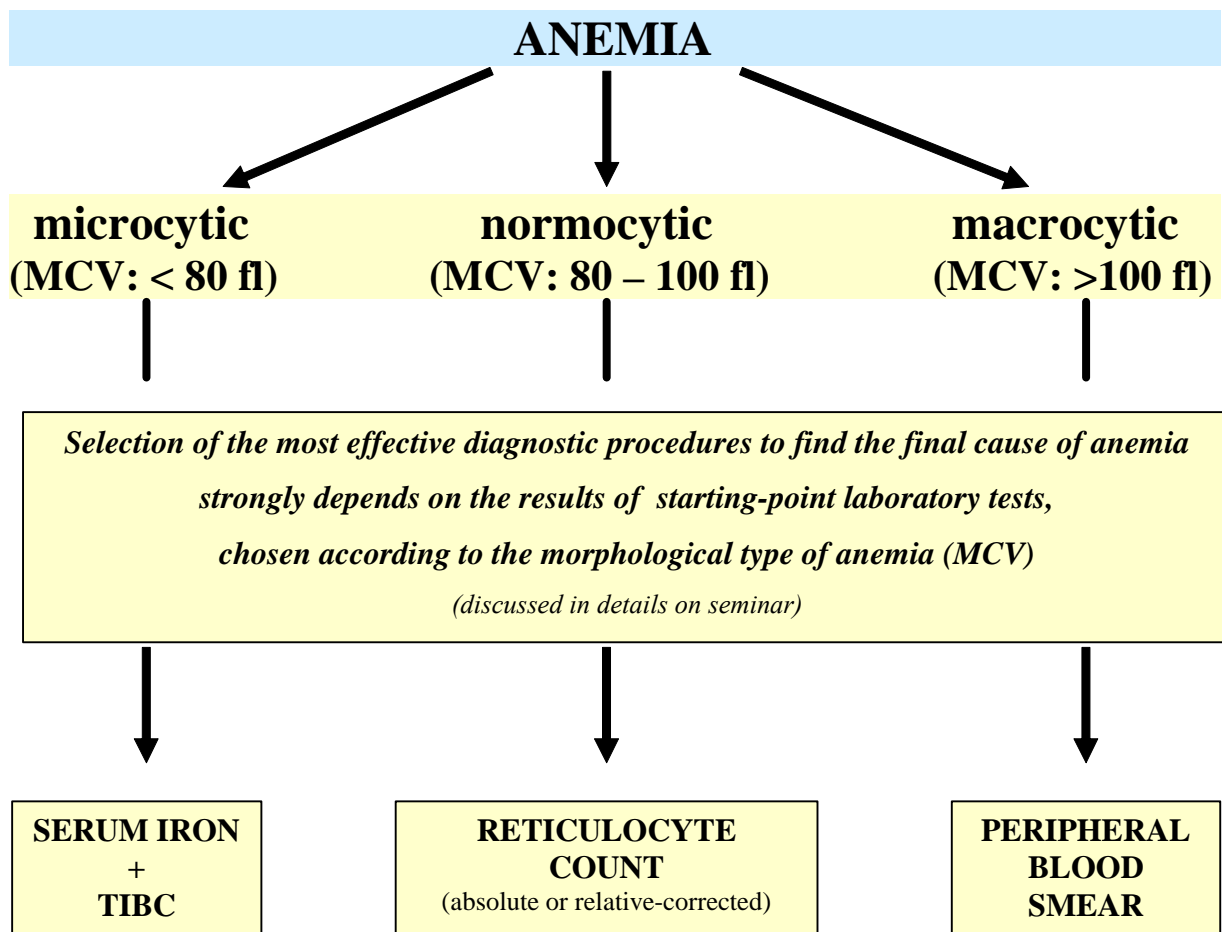

## REFERENCES *(concerning both exercises devoted to hematology - I and II)*

1. Kumar, Abbas , Fausto (ed.): **Robins and Cotran Pathologic Basis of Disease** (7<sup>th</sup> ed.). Elsevier/Saunders 2005 – Chapters: 4 and 13.
2. Henry B J (ed.): **Clinical Diagnosis and Management by Laboratory Methods.** (20<sup>th</sup> ed.). W.B. Saunders Company 2001 – Chapters: 24-26 and 28-29.
3. Kasper, Braunwald, Fauci, Hauser, Longo, James (ed): **Harrison’s principles of internal medicine.** (16<sup>th</sup> ed.). McGraw-Hill 2005 – Chapters: 52-53; 90-94; 101-103.
4. Gross S., Roath S. (ed.): **Hematology. A Problem - Oriented Approach.** Williams & Wilkins, Baltimore 1996.
5. Rodak B: **Diagnostic Hematology.** W.B. Saunders Company, Philadelphia 1995.
6. Isbister J.P. , Pittiglio D.H.: **Clinical Hematology. A Problem - Oriented Approach.** Williams & Wilkins, Baltimore 1988.

## HEMOSTASIS

=

the complex process including mechanisms which are to:

prevent blood loss  
from sites of vascular disruption

and

maintain blood fluency

=

## DELICATE BALANCE

between

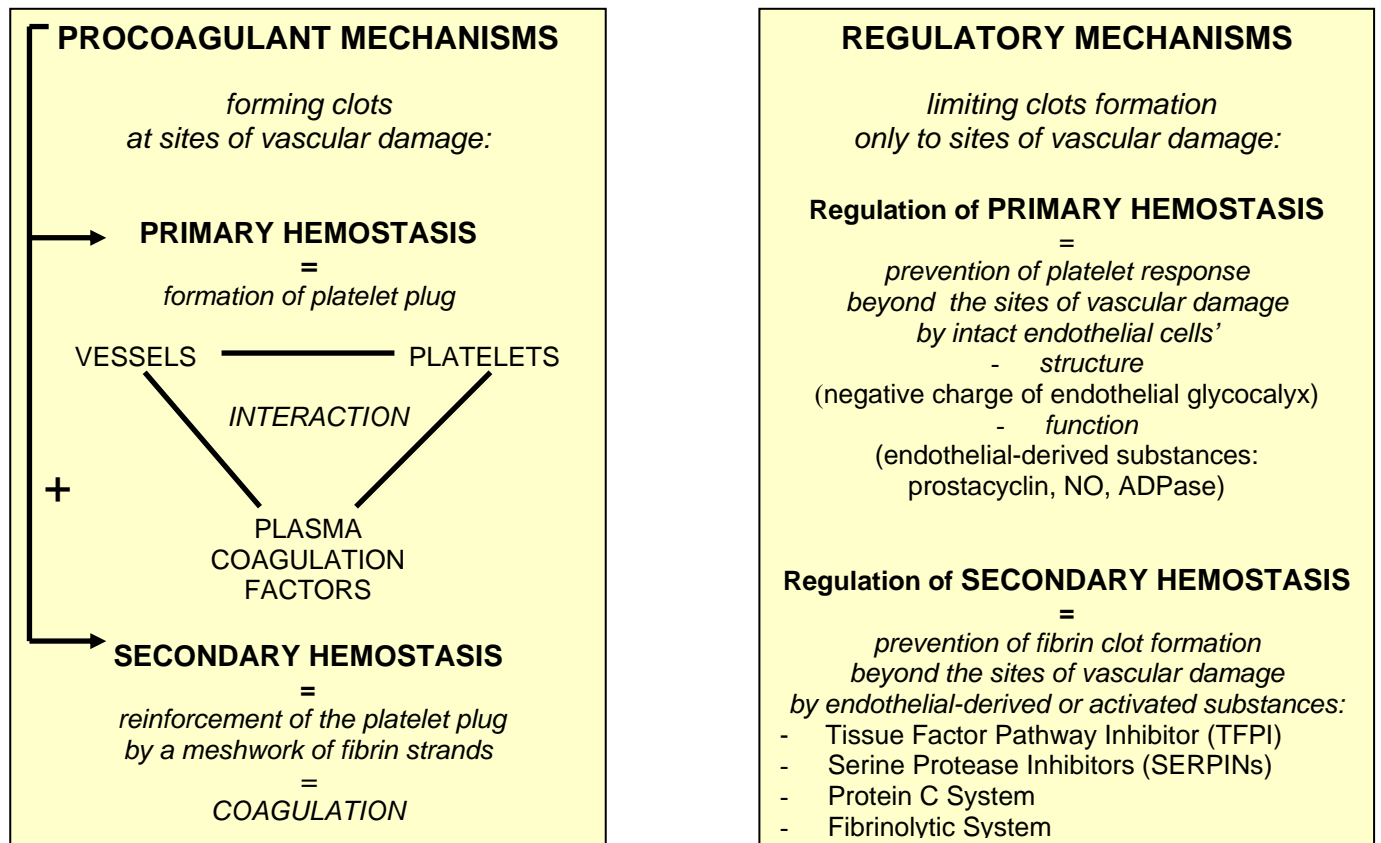

if this **BALANCE** is disturbed

HYPOCOAGULABLE STATE  
due to:

- decreased procoagulant activity (e.g. deficiency of coagulation factors)
- increased regulatory activity (e.g. fibrinolytic syndrome)

=  
**BLEEDING DISORDER**

HYPERCOAGULABLE STATE  
due to:

- decreased regulatory activity (e.g. deficiency of natural anticoagulants)
- increased procoagulant activity (clinical conditions leading to endothelial injury or/and abnormal blood flow; see: Virchow's triad)

=  
**THROMBOTIC DISORDER**

This chapter aims to present  
**THE DIAGNOSTIC SIGNIFICANCE**  
**OF**  
**BASIC LABORATORY TESTS**  
 (ROUTINE SCREENING)  
 commonly performed...

GENERALIZED:  
 - BLEEDING  
 (from multiple sites)  
 - BRUISING  
 - PURPURA

INAPPROPRIATE  
 LOCAL BLEEDING  
 WITHOUT OBVIOUS  
 MECHANICAL CAUSE

PAST HISTORY OF  
 INAPPROPRIATE  
 BLEEDING  
 e. g. after dental  
 extraction or trauma

...WHEN  
**BLEEDING  
 DISORDER**  
 IS  
 SUSPECTED

INCREASED RISK OF  
 HEMOSTATIC FAILURE  
 related to:  
 I. Family History  
  
 II. Underlying  
 Clinical Condition, e.g.:  
 - primary disorders of  
 hematopoietic system  
 - liver or kidney disease  
 - hypercortisolism  
 - anticoagulant or  
 antiplatelet drugs  
 - vit. K or C deficiency  
  
 III. Incidental laboratory  
 abnormalities detected  
 in the course of other  
 investigations

← 'SYMPTOMATIC PATIENTS'  
 (in terms of hemorrhagic diathesis)

← 'ASYMPTOMATIC PATIENTS'  
 (in terms of hemorrhagic diathesis)

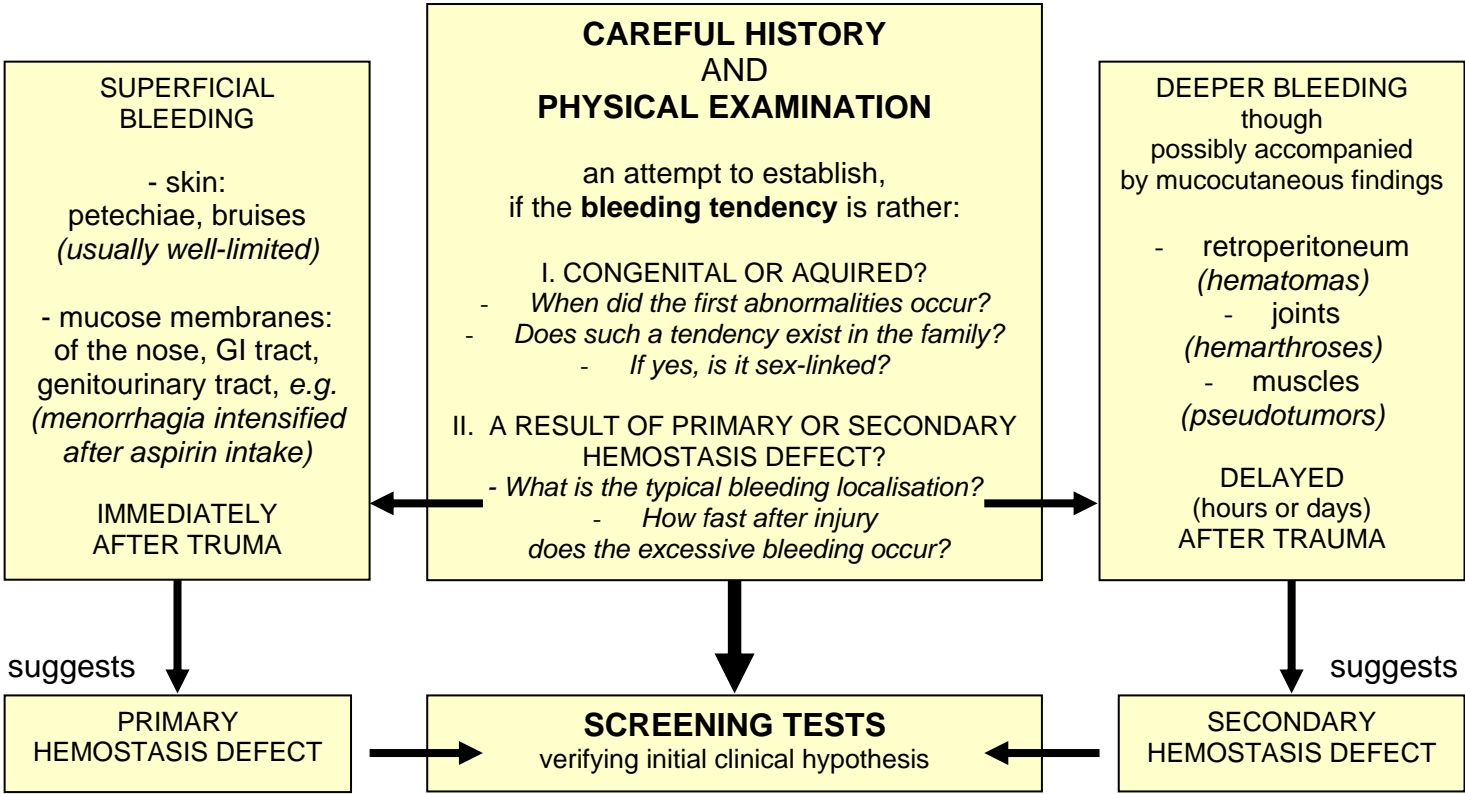

**SCREENING LABORATORY TESTS  
TO EVALUATE**

**PRIMARY HEMOSTASIS**  
(FORMATION OF THE PLATELET PLUG)

AND

**SECONDARY HEMOSTASIS**  
(COAGULATION)



*FIRST STEP SCREENING*



**BT**  
(Bleeding Time)  
+  
**PLT**  
(Platelet count in CBC)

**APTT**  
(Activated Partial  
Thromboplastin Time)  
+  
**PT**  
(Prothrombin Time)



*SECOND STEP SCREENING*



**BLOOD SMEAR**  
*(optional)*

**FIBRINOGEN**  
(and possibly)  
Thrombin Time - TT  
+  
**APTT / PT  
MIXING STUDY**



*ADDITIONAL  
LABORATORY TESTS*



**PLATELET  
FUNCTIONAL  
TESTS**

**FACTOR ASSAY  
OR  
INHIBITOR STUDY**

WHILE IN HYPOCOAGULABLE STATES BT, APTT, PT ARE USUALLY PROLONGED,  
(according to results' configuration a defect in procoagulant mechanisms may be located)  
IN HYPERCOAGULABLE STATES BT, APTT, PT REMAIN USUALLY NORMAL.

THEREFORE - UNLIKE BLEEDING - IN DIAGNOSIS OF THROMBOTIC DISORDERS,  
**BT, APTT, PT ARE NOT ACTUALLY HELPFUL.**

**APTT AND PT ARE HOWEVER USED IN THROMBOTIC DISORDERS,  
THOUGH LESS FROM DIAGNOSTIC THAN THERAPEUTIC REASONS,  
—————> TO MONITOR ANTICOAGULANT TREATMENT**

ONE COULD HARDLY UTILIZE THE SCREENING TESTS  
IN THE DIAGNOSIS OF BLEEDING DISORDERS  
WITHOUT GOOD UNDERSTANDING OF HEMOSTASIS  
(at least to the extent it is evaluated by these tests)

SO, WILLY NILLY, WE HAVE TO FOLLOW IT!

VASCULAR DISRUPTION INITIATES SIMULTANEOUSLY...

**3 PROCESSES**

**PLATELET - VASCULAR  
INTERACTION**

TO FORM  
A PLATELET PLUG

*initiated by  
platelets' adhesion  
to exposed  
subendothelial tissue*

PRIMARY HEMOSTASIS

**BT**

**INTRINSIC  
COAGULATION PATHWAY**

(all components are found  
in the circulating blood)

TO FORM THROMBIN  
with subsequent  
FIBRINOGEN TO FIBRIN  
CONVERSION

*initiated by  
binding of contact group  
factors (XII, XI, HMWK, PK)  
to negatively charged  
surfaces of collagen and  
activated platelets*

SECONDARY HEMOSTASIS

**APTT**

**EXTRINSIC  
COAGULATION PATHWAY**

(requires a component normally  
absent in the circulating blood)

TO FORM THROMBIN  
with subsequent  
FIBRINOGEN TO FIBRIN  
CONVERSION

*initiated by  
blood occurrence of  
tissue factor (TF) -  
a membrane glycoprotein  
coming from subendothelial  
and surrounding tissues*

EVALUATED

BY

**PT**

THE DIAGNOSTIC SIGNIFICANCE OF EACH OF THESE TESTS WILL BE PRESENTED ON  
FOLLOWING PAGES, AGAINST THE BACKGROUND OF THE ADEQUATE PART OF HEMOSTASIS.  
DIFFERENT CONFIGURATIONS OF ABNORMAL RESULTS IN CONTEXT OF CLINICAL PICTURE  
AS A STARTING-POINT OF BLEEDING DISORDERS' DIFFERENTIAL DIAGNOSIS  
ARE DISCUSSED DURING EXERCISES.

PARTICULAR ATTENTION IS PAID TO THE COMMONEST CAUSES  
OF HEMORRHAGIC DIATHESES, SUCH AS:

PRIMARY ← HEMOSTASIS DEFECT → SECONDARY

CONGENITAL      **von Willebrand's Disease**

**Hemophilia A**

AQUIRED      **Thrombocytopenia**

**Liver Disease**  
**Vitamin K Deficiency**

**PRIMARY HEMOSTASIS**  
 =  
**FORMATION OF PLATELET PLUG**  
 (+VASOCONSTRICTION)  
**TO ARREST BLEEDING AS QUICKLY AS POSSIBLE**

THERE ARE 3 MAJOR STEPS (3 X A)  
 OF PLATELET RESPONSE TO VASCULAR INJURY

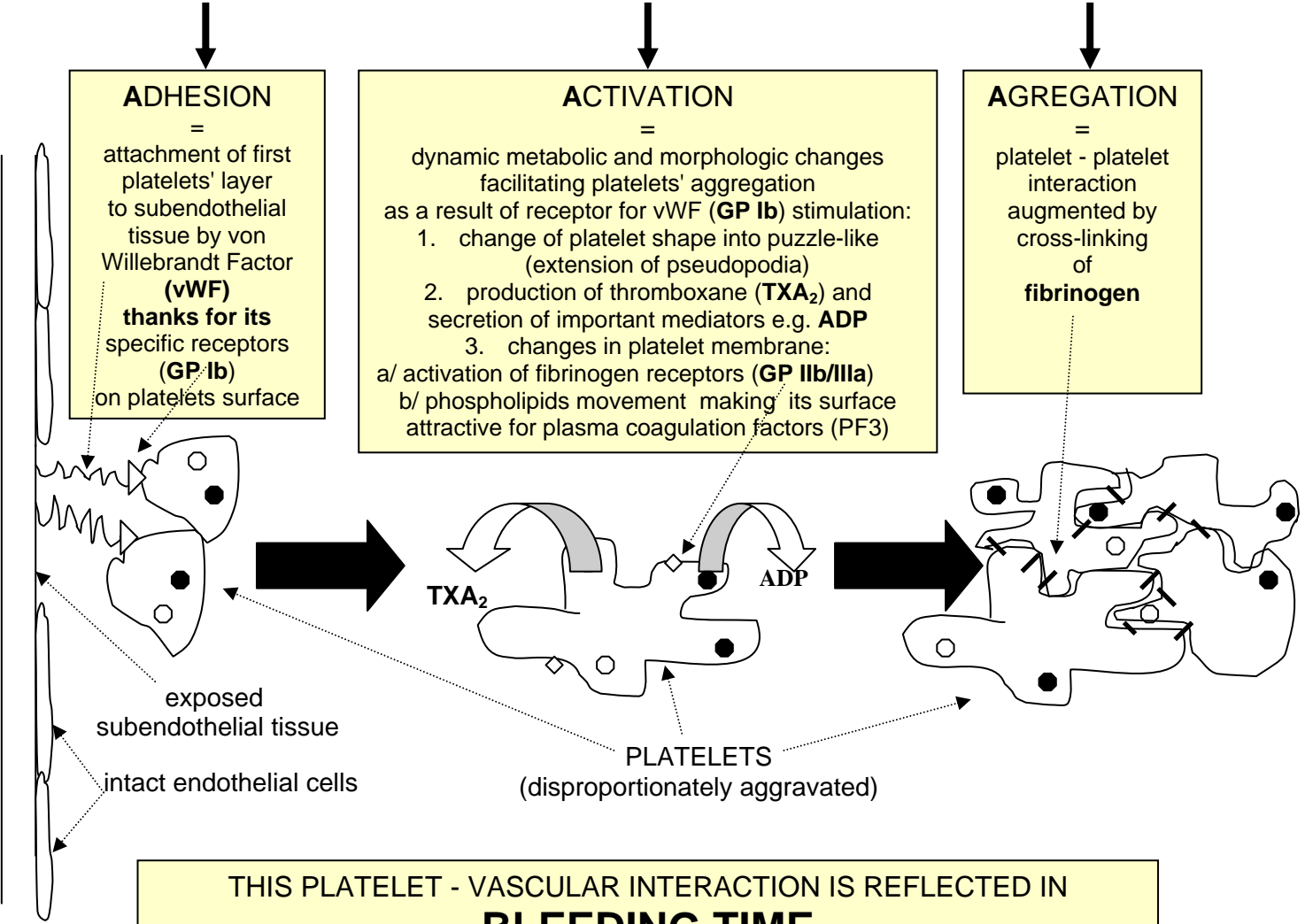

**ADHESION**  
 =  
 attachment of first platelets' layer to subendothelial tissue by von Willebrandt Factor (**vWF**) thanks for its specific receptors (**GP Ib**) on platelets surface

**ACTIVATION**  
 =  
 dynamic metabolic and morphologic changes facilitating platelets' aggregation as a result of receptor for vWF (**GP Ib**) stimulation:

1. change of platelet shape into puzzle-like (extension of pseudopodia)
2. production of thromboxane (**TXA<sub>2</sub>**) and secretion of important mediators e.g. **ADP**
3. changes in platelet membrane:  
 a/ activation of fibrinogen receptors (**GP IIb/IIIa**)  
 b/ phospholipids movement making its surface attractive for plasma coagulation factors (PF3)

**AGREGATION**  
 =  
 platelet - platelet interaction augmented by cross-linking of **fibrinogen**

THIS PLATELET - VASCULAR INTERACTION IS REFLECTED IN  
**BLEEDING TIME**

THEREFORE BT IS USUALLY PROLONGED IN A DEFECT OF:

- I. **PLATELETS:**
  - Ia. quantitative - thrombocytopenia
  - Ib. qualitative - hereditary or acquired platelet dysfunction
- II. **VESSELS** - hereditary or acquired vascular disorders
- III. **INTERACTION (itself), at the stage of:**
  - IIIa. **ADHESION:** von Willebrand's Disease
  - IIIb. **ACTIVATION:** (besides Ib) NSAID or other antiplatelet drugs
  - IIIc. **AGREGATION:** severe hypo- or dysfibrinogenemia

**CAUTION!!!**  
 Apart from factor I (fibrinogen), deficiency of any coagulation factor (e. g. hemophilia)  
 DO NOT PROLONG BLEEDING TIME,  
 SINCE IT ONLY REFLECTS PRIMARY BUT NOT SECONDARY HEMOSTASIS!

# SECONDARY HEMOSTASIS

## = REINFORCEMENT AND STABILIZATION OF PLATELET PLUG AT THE SITE OF VASCULAR DISRUPTION BY FORMATION OF FIBRIN CLOT

TWO MAJOR PHASES:

I. FORMATION OF THE POTENT PROCOAGULANT ENZYME - **THROMBIN**  
in multiple enzymatic steps collectively known as  
**COAGULATION CASCADE**

II. CONVERSION OF SOLUBLE PROTEIN - **FIBRINOGEN**  
N INTO INSOLUBLE GEL OF **FIBRIN** MESHWORK

Although both intrinsic and extrinsic pathways are simultaneously activated, the **extrinsic** one is nowadays regarded to play a **major physiological role** in initiating the coagulation cascade.

Plasma occurrence of TF rapidly generates a trace amount of thrombin, which significantly facilitates the course of intrinsic pathway (by activation of its pivotal cofactors, e.g. V and VIII, and factor XI).

To prevent the disseminated coagulation extrinsic pathway is quickly inhibited by TFPI and thrombin formation continued by intrinsic pathway.

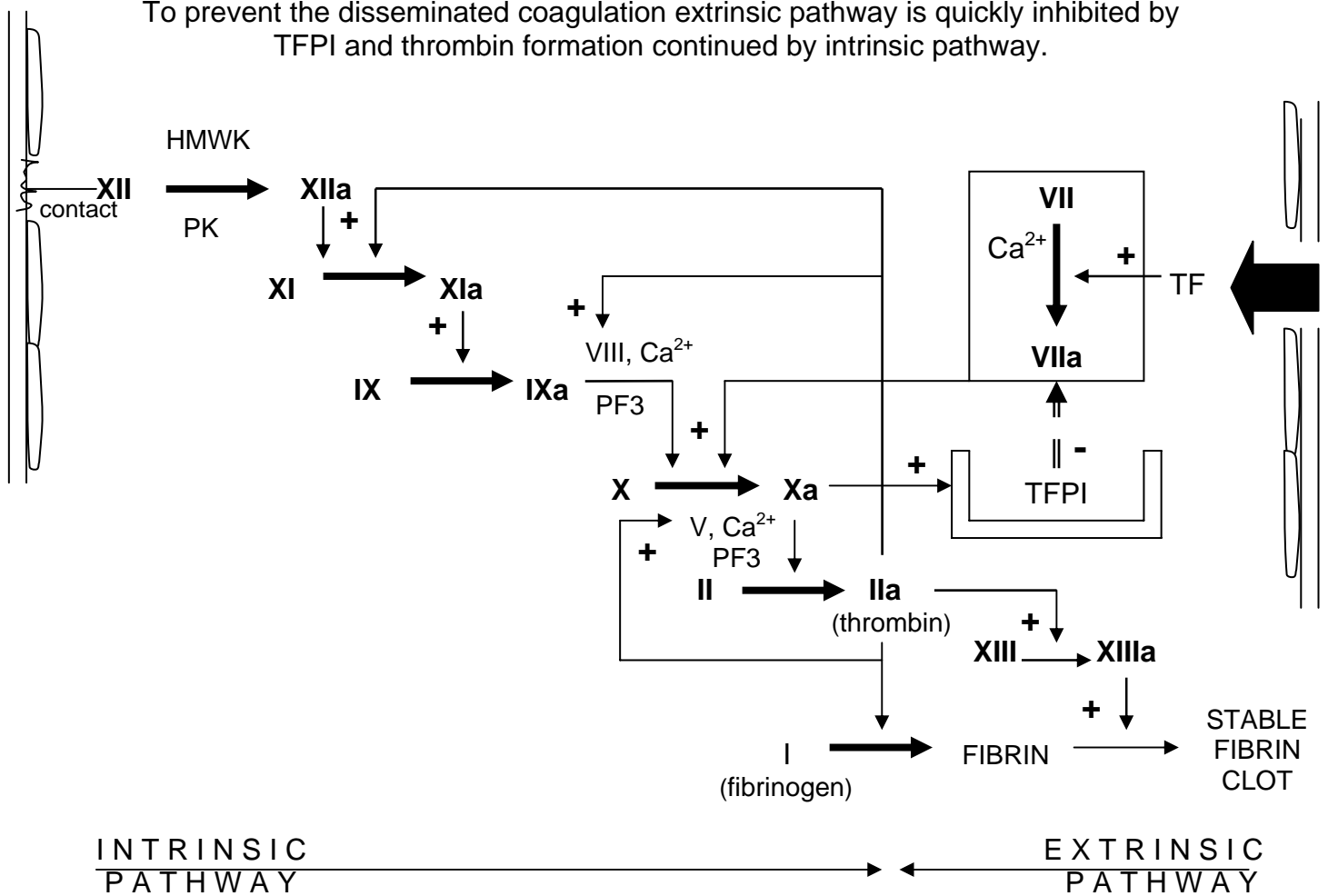

**SERINE PROTEASES :**  
**OTHER ENZYMES:**  
**COFACTORS:**

**FACTORS XII, XI + vitamin K-dependent FACTORS (X, IX, VII, II)**  
**FACTOR XIII** (transglutaminase stabilizing fibrin clot)  
- **HMWK** (High Molecular Weight Kininogen),  
- **PK** (Prekallikrein)  
- **PF3** (phospholipids on activated platelets' surface)  
- **FACTORS VIII, V and IV (Ca)**

**OTHER FACTORS:**

**FACTOR III (TISSUE FACTOR - TF), FACTOR I (FIBRINOGEN)**



# LABORATORY EVALUATION OF SECONDARY HEMOSTASIS

The idea is to induce and examine in vitro (in patient's citrated plasma) either intrinsic or extrinsic pathway, separately.

Calcium ions - the necessary cofactor for both pathways -

had been previously inhibited by citrate to prevent a spontaneous coagulation.

So to induce it later under controlled circumstances Ca must be added (citrate chloride) to plasma along with substances of similar properties to specific activators for each pathway in vivo.

to check intrinsic or extrinsic pathway → citrated plasma + CaCl<sub>2</sub> + **SPECIFIC ACTIVATORS**

ISOLATED PRIMARY HEMOSTASIS DEFECT (DUE TO PLATELETS, VESSELS or INTERACTION) DOES NOT PROLONG THESE TIMES!!!

## INTRINSIC PATHWAY - APTT (Activated Partial Thromboplastin Time) =

CITRATED PLASMA + CaCl<sub>2</sub> + ACTIVATORS (specific for intrinsic pathway), i. e.

- some negatively charged surface (instead of collagen), e. g. kaolin
- some phospholipids (instead of PF3) – “partial thromboplastin”, e. g. cephalin

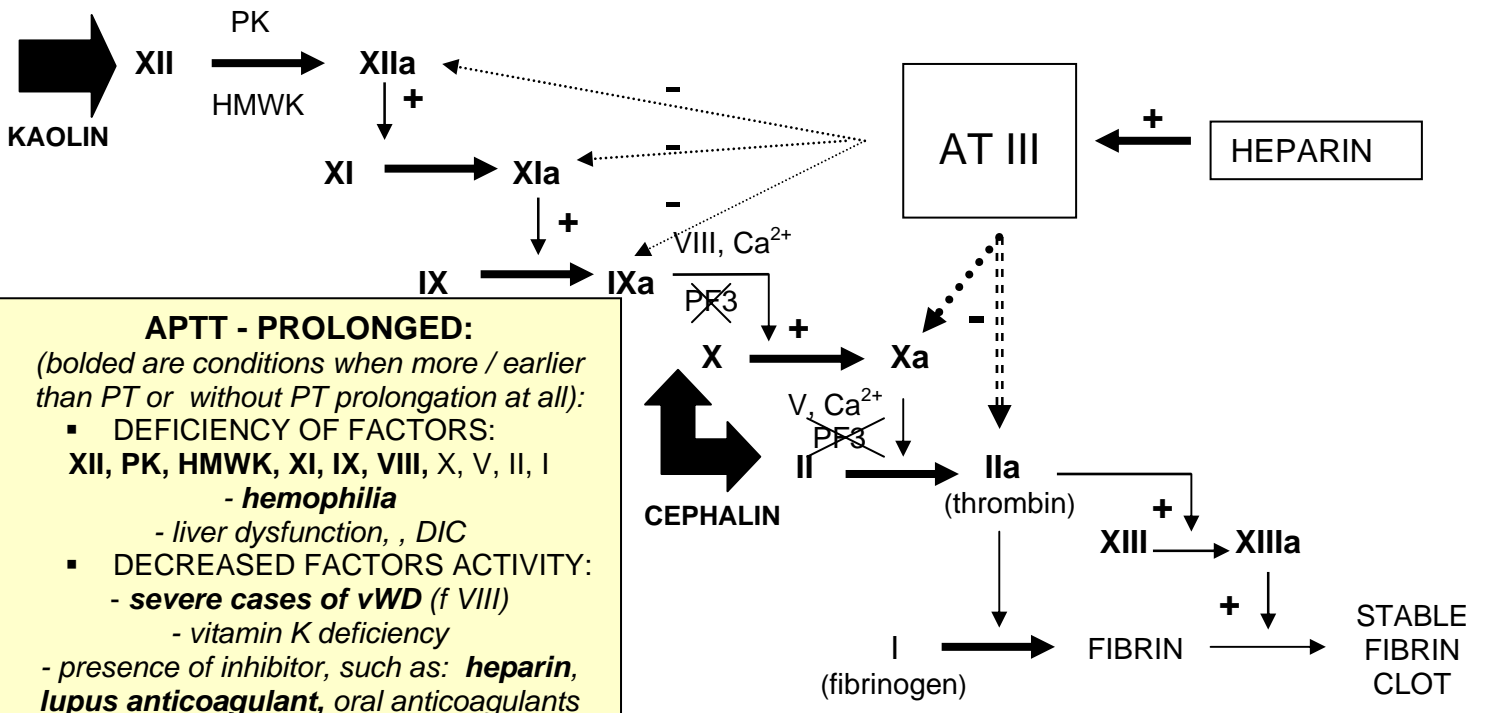

## EXTRINSIC PATHWAY – PT (Prothrombin Time) =

CITRATED PLASMA + CaCl<sub>2</sub> + ACTIVATOR (specific for extrinsic pathway), i. e.

- “full thromboplastin” = tissue extract (e.g. from the brain) = TF + phospholipids

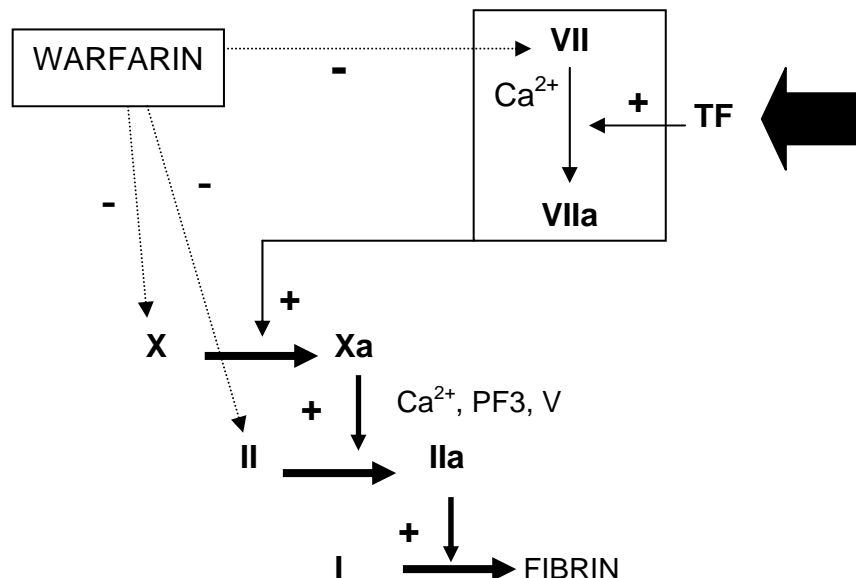

## APTT / PT RESULTS IN CONFIGURATION - SUMMARY

APTT	PT	<b>CAUSES</b> and <b>EXPLANATIONS</b>
<b>↑</b>	<b>N</b>	<p><b>DEFICIENCIES or DECREASED ACTIVITY OF FACTORS:</b></p> <ul style="list-style-type: none"> <li>▪ <b>VIII:</b> - hemophilia A, - severe cases of von Willebrand's disease (vWF = carrier for f VIII) - circulating inhibitor of factor VIII (supplemental treatment of hemophilia A or post partum)</li> <li>▪ <b>IX</b> (hemophilia B),</li> <li>▪ <b>XI</b> (hemophilia C)</li> <li>▪ <b>XII, HMWK, PK</b> – no affect on clotting in vivo – no bleeding!!!</li> </ul>
<b>↑</b>	<b>↑ or N</b>	<ul style="list-style-type: none"> <li>▪ <b>lupus anticoagulant</b> – inhibits phospholipids (replacing PF3)</li> </ul>
<b>↑</b>	<b>↑</b>	<ul style="list-style-type: none"> <li>▪ <b>heparin treatment</b> – by activating ATIII inhibits factors: <b>Ila Xa IXa, Xla, XIIa</b></li> </ul>
<b>N</b>	<b>↑</b>	<p style="text-align: center;"><b>DEFICIENCY OF FACTOR VII</b></p> <ul style="list-style-type: none"> <li>▪ <b>hereditary</b> (rare)</li> <li>▪ <b>early stage of liver disease</b> - although almost all coagulation factors are produced in the liver, decreased synthesis particularly affects f. VII, since its most rapid turnover, thus it is earlier reflected in PT than APTT</li> </ul>
<b>↑</b>	<b>↑</b>	<p style="text-align: center;"><b>DEFICIENCY OF FACTOR VII and FACTORS LOCATED IN COMMON PATHWAY (I, II, V, X)</b></p> <ul style="list-style-type: none"> <li>▪ <b>vitamin k deficiency / oral anticoagulants</b> - in both conditions the activity of vitamin K - dependent factors (II, VII, IX, X) as well as protein C and S is decreased; for the reasons mentioned above it particularly affects f. VII</li> <li>▪ <b>intermediate stage of liver disease evolution</b></li> </ul>
<b>↑</b>	<b>↑</b>	<p style="text-align: center;"><b>MULTIPLE FACTOR DEFICIENCIES</b></p> <ul style="list-style-type: none"> <li>▪ <b>advanced liver disease</b></li> <li>▪ <b>DIC</b></li> </ul>

## CONFIGURATIONS OF SCREENING LABORATORY TESTS RESULTS IN THE MOST COMMON BLEEDING DISORDERS

DISORDER	BT	PLT	APTT	PT	Fibrinogen
<b>thrombocytopenia</b>	↑	↓	N	N	N
<b>thrombocytopathy</b> (e.g. Glanzmann thrombastenia)	↑	N	N	N	N
<b>von Willebrand's disease</b>	↑	N	N / ↑	N	N
<b>hemophilia</b>	N	N	↑	N	N
<b>heparin treatment</b>	N	N	↑	↑	N
<b>oral anticoagulants</b>	N	N	↑	↑	N
<b>advanced liver disease</b> (numbers indicate the sequence of events)	4 ↑	5 ↓	2 ↑	1 ↑	3 ↓
<b>DIC</b> (advanced stage)	↑	↓	↑	↑	↓

# The evaluation of acid-base balance in clinical practice

Waldemar Myszka MD

## Key definitions and formulas for clinical acid-base problem solving

<p><b>Rule 1.</b> Determine pH status (alkalemia or acidemia)</p>
<p><b>Rule 2.</b> Determine whether the primary process is respiratory, metabolic or both.</p> <p><b>Alkalosis</b></p> <ul style="list-style-type: none"><li>– Respiratory Alkalosis: if pCO<sub>2</sub> substantially less than 35 mmHg</li><li>– Metabolic Alkalosis: if bicarbonate greater than 26 mmol/L</li></ul> <p><b>Acidosis</b></p> <ul style="list-style-type: none"><li>– Respiratory Acidosis: if pCO<sub>2</sub> greater than 45 mmHg</li><li>– Metabolic Acidosis: if bicarbonate less than 22 mmol/L</li></ul>
<p><b>Rule 3.</b> Calculate the serum anion gap</p> <p>Anion gap = Sodium – (Bicarbonate + Chloride)</p> <ul style="list-style-type: none"><li>– Anion gap that is increased (greater than 10 mEq/L can indicate metabolic acidosis</li><li>– Anion gap increased beyond 20 mEq/L always indicates a metabolic acidosis</li><li>– For every 1 g/dL albumin below normal add 2,5 to the calculated anion gap</li></ul>
<p><b>Rule 4.</b> Check the degree of compensation</p> <p><b>Metabolic Acidosis</b></p> <ul style="list-style-type: none"><li>– <math>P_{CO_2} = 1.5 \times (HCO_3^-) + 8 \pm 2</math></li><li>– P<sub>CO2</sub> falls by 1 – 1.3 mmHg for each mEq/L fall in (HCO<sub>3</sub><sup>-</sup>)</li><li>– Last 2 digits of pH = P<sub>CO2</sub> (thus if P<sub>CO2</sub> = 28, pH = 7.28)</li></ul> <p><b>Metabolic Alkalosis</b></p> <ul style="list-style-type: none"><li>– P<sub>CO2</sub> increases 6 mmHg for each 10 mEq/L rise in HCO<sub>3</sub><sup>-</sup></li><li>– <math>HCO_3^- + 15 = pCO_2</math></li></ul> <p><b>Respiratory Acidosis</b></p> <p><i>Acute:</i> HCO<sub>3</sub><sup>-</sup> increases by 1 mEq/L for each 10 mmHg rise in P<sub>CO2</sub></p> <p><i>Chronic:</i> HCO<sub>3</sub><sup>-</sup> increases by 4 mEq/L for each 10 mmHg rise in P<sub>CO2</sub></p> <p><b>Respiratory Alkalosis</b></p> <p><i>Acute:</i> HCO<sub>3</sub><sup>-</sup> falls by 2 mEq/L for each 10 mmHg fall in P<sub>CO2</sub></p> <p><i>Chronic:</i> HCO<sub>3</sub><sup>-</sup> falls by 4 for each 10 mmHg fall in P<sub>CO2</sub></p>
<p><b>Rule 5.</b> Determine whether there is a 1:1 relationship between anions in blood (also called delta gap)</p> <p><i>Refers to increased anion gap metabolic acidosis</i></p>

## Normal values of tests utilized for acid-base problem solving

<b>Arterial blood gases</b>	pH – 7.35-7.45 pO <sub>2</sub> – 8.7-12.7 kPa (65-95 mmHg) pCO <sub>2</sub> – 4.8-6.0 kPa (35-45 mmHg) HCO <sub>3</sub> <sup>-</sup> – 22-26 mmol/l BE – ± 2.5 mmol/l
<b>Anion gap</b>	AG - 3 – 12 mEq/l
<b>Plasma electrolytes concentration</b>	Na <sup>+</sup> – 135-145 mmol/l K <sup>+</sup> – 3.5-5.0 mmol/l Cl <sup>-</sup> – 98-107 mmol/l HCO <sub>3</sub> <sup>-</sup> – 22-26 mmol/l Ca – 2.12-2.62 mmol/l (8.5-10.5 mg/dl) Ca <sup>2+</sup> – 0.98-1.13 mmol/l Mg <sup>2+</sup> – 0.8-1.0 mmol/l (1.9-2.5 mg/dl) PO <sub>4</sub> <sup>2-</sup> – 0.97-1.45 mmol/l (3.0-4.5 mg/dl)
<b>Urine electrolytes daily excretion</b>	Na <sup>+</sup> –80-240 mmol/24 h K <sup>+</sup> – 25-80 mmol/24 h Cl <sup>-</sup> – 110-260 mmol/24 h
<b>Albumin</b>	35-50 g/l

## Classification of the primary acid-base disorders based on arterial blood pH and pCO<sub>2</sub> tension findings

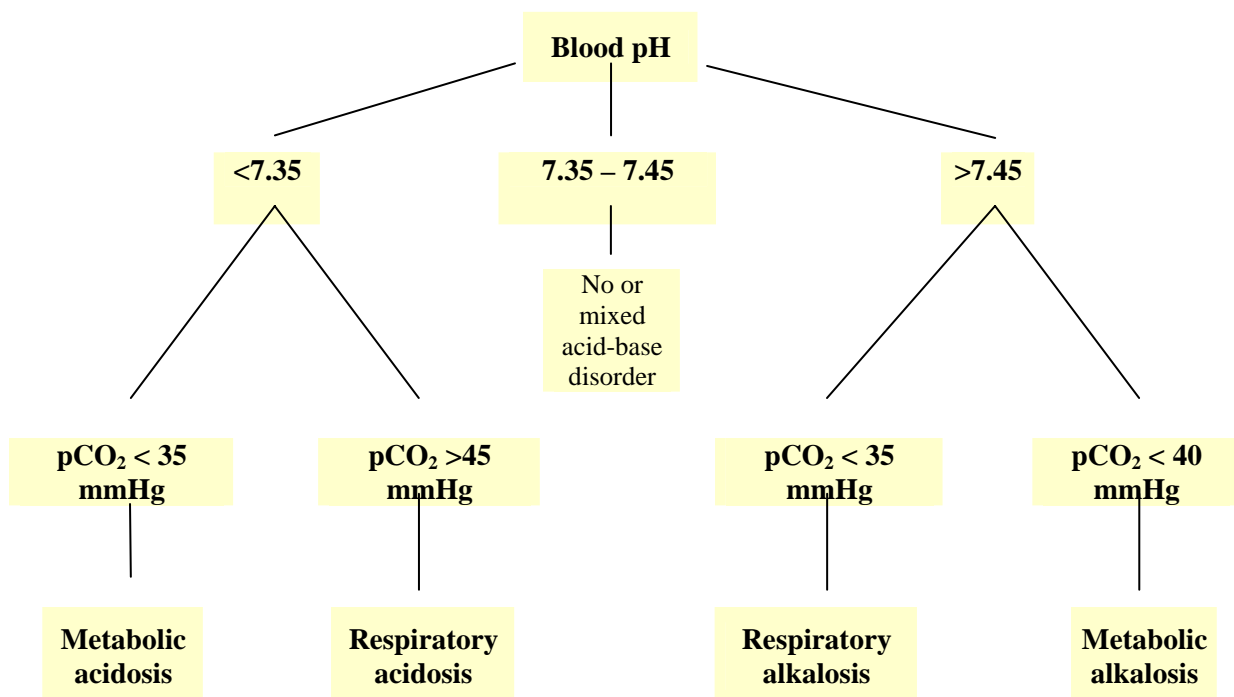

## Relations between three parameters describing acid-base balance

	pH	HCO <sub>3</sub> <sup>-</sup>	pCO <sub>2</sub>
<b>Metabolic acidosis</b>	↓	↓	↓
<b>Metabolic alkalosis</b>	↑	↑	↑
<b>Respiratory acidosis</b>	↓	↑	↑
<b>Respiratory alkalosis</b>	↑	↓	↓

*Note: primary changes leading to pH alterations are circled*

## Metabolic acidosis

### Classification based on the serum anion gap (AG) and K<sup>+</sup> concentration

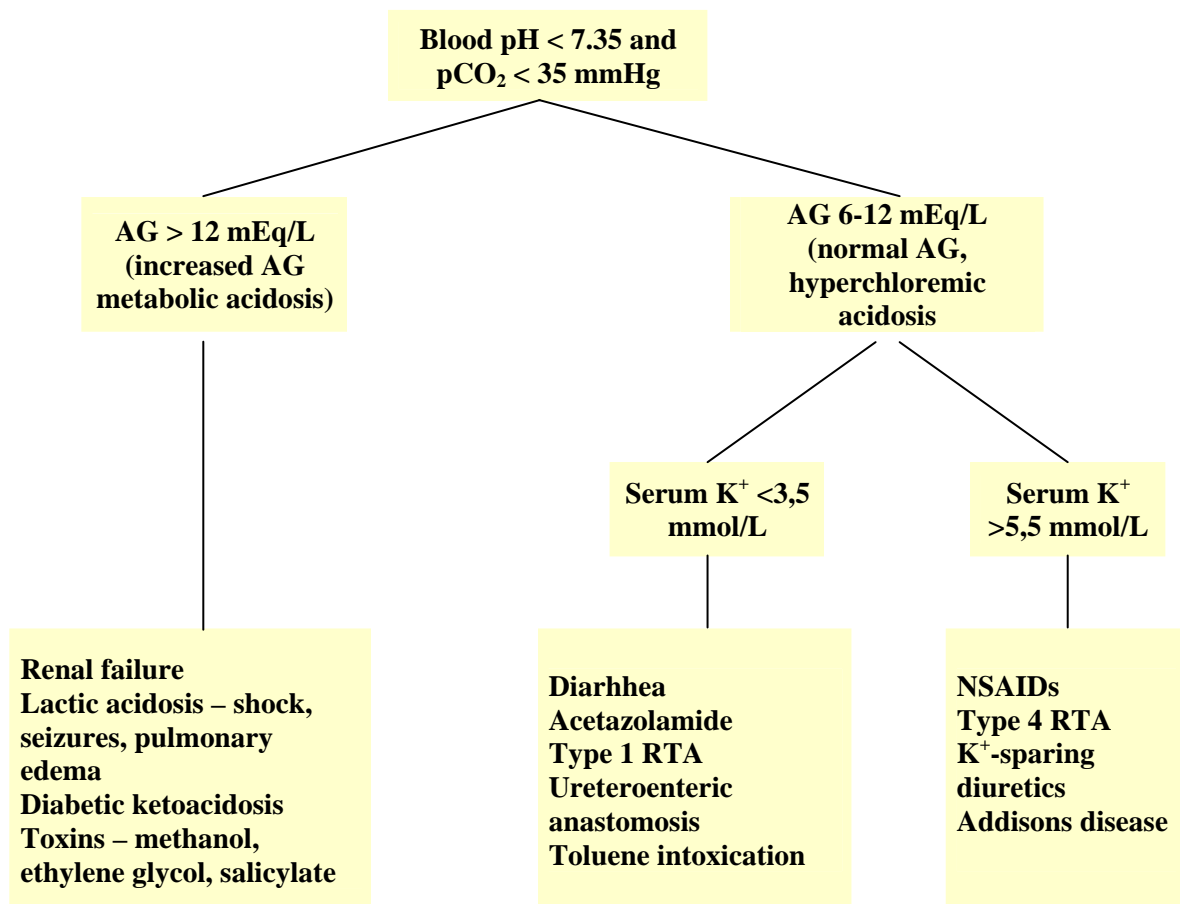

## Principles of treatment of metabolic acidosis

1. Assess the severity of disorder - mild disturbances may have little clinical significance and require no corrective therapy. If the underlying cause can be treated effectively, there is often no need for specific therapy of the acid-base disorder.
2. When specific treatment is indicated, complete correction of the disturbance is usually not necessary. The goal is to correct the disorder toward normal and allow the body to make the fine adjustments itself.
3. The acuteness and severity of the disorder often determines the rapidity and aggressiveness with which it should be corrected.
4. The acid-base status must be monitored frequently and the treatment modified according to the patient's response.
5. The use of the alkali is frequently recommended when the arterial pH is less than 7.2 or the serum bicarbonate is 12 mEq/L or less.
6. Metabolic acidosis should not be corrected aggressively (if not pH of the CSF may decrease further leading to obtundation, convulsion, coma).
7. Remember: it is crucial to monitor serum potassium levels when acid-base disorders are corrected.
8. Estimation of bicarbonate required for correction of acidosis:

$$[\text{HCO}_3^-] \text{ deficit} = [24 \text{ mEq/L} - \text{measured HCO}_3^-] \times 0.5 \times \text{body weight}$$

One half of the calculated deficit may be replaced in 3 to 4 hours in concentration 50 – 150 mEq/L

## Metabolic alkalosis

### Classification based on whether the cause is chloride depletion (with low urinary $[\text{Cl}^-]$ or not)

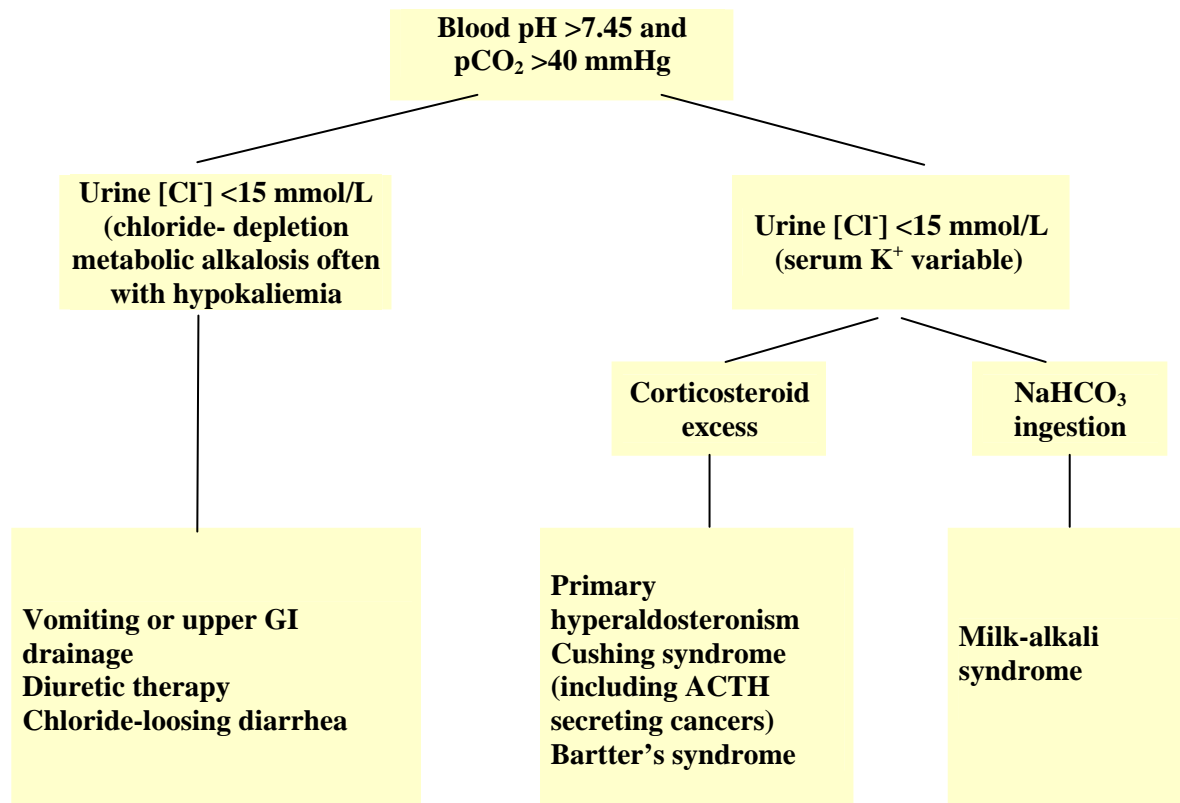

## Respiratory acidosis

Classification based on whether the problem is acute or chronic and then whether there is a chest, central nervous system, or peripheral neuromuscular disorder

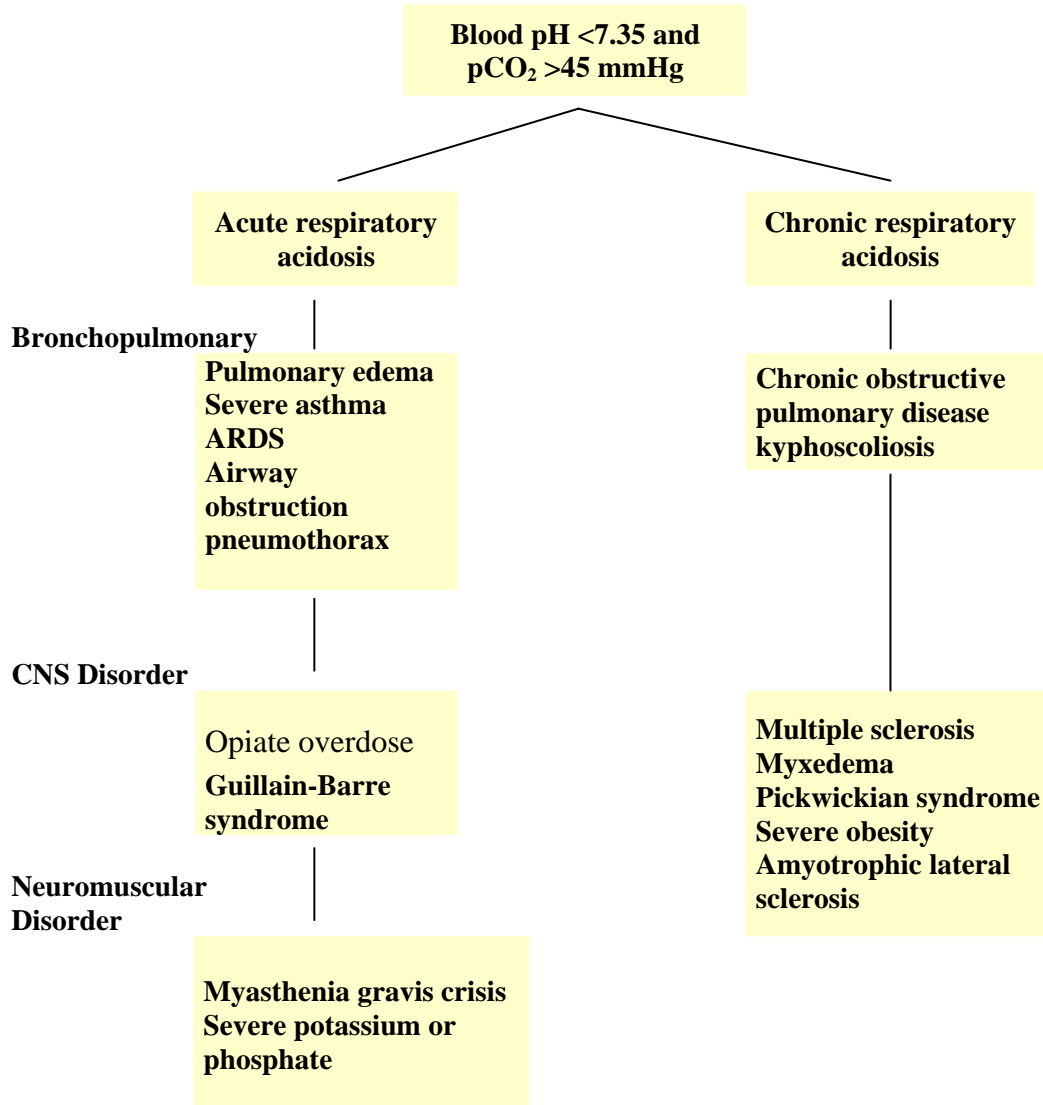



## Respiratory alkalosis

Classification based on whether there is hypoxemia and an increased A-a (alveolo-arterial) oxygen gradient

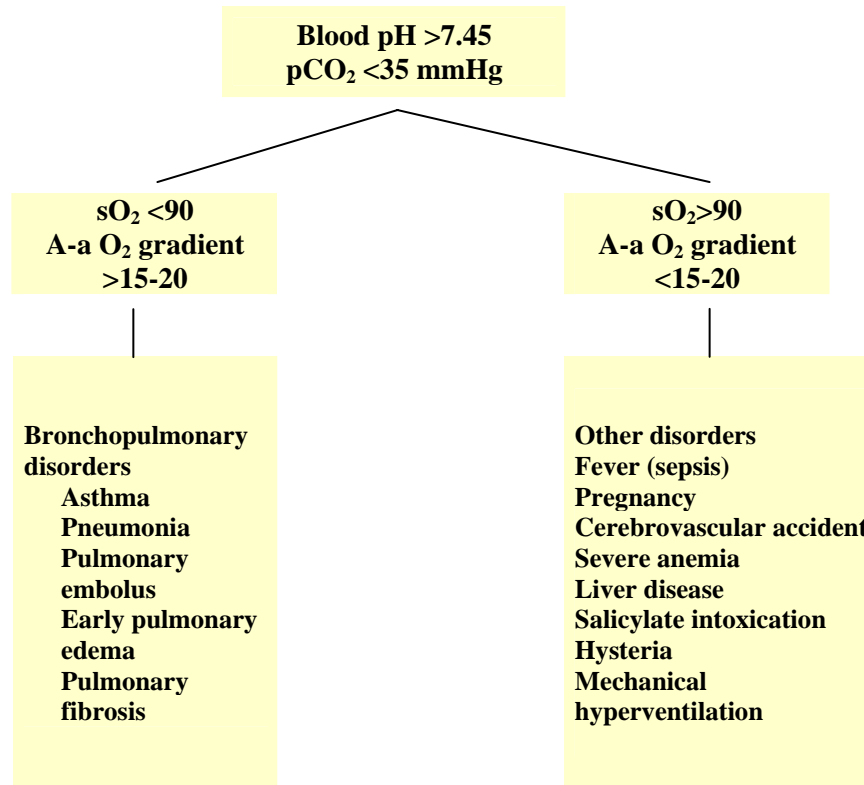

## Mixed acid-base disorders

Classification based on arterial blood pH and CO<sub>2</sub> tension findings

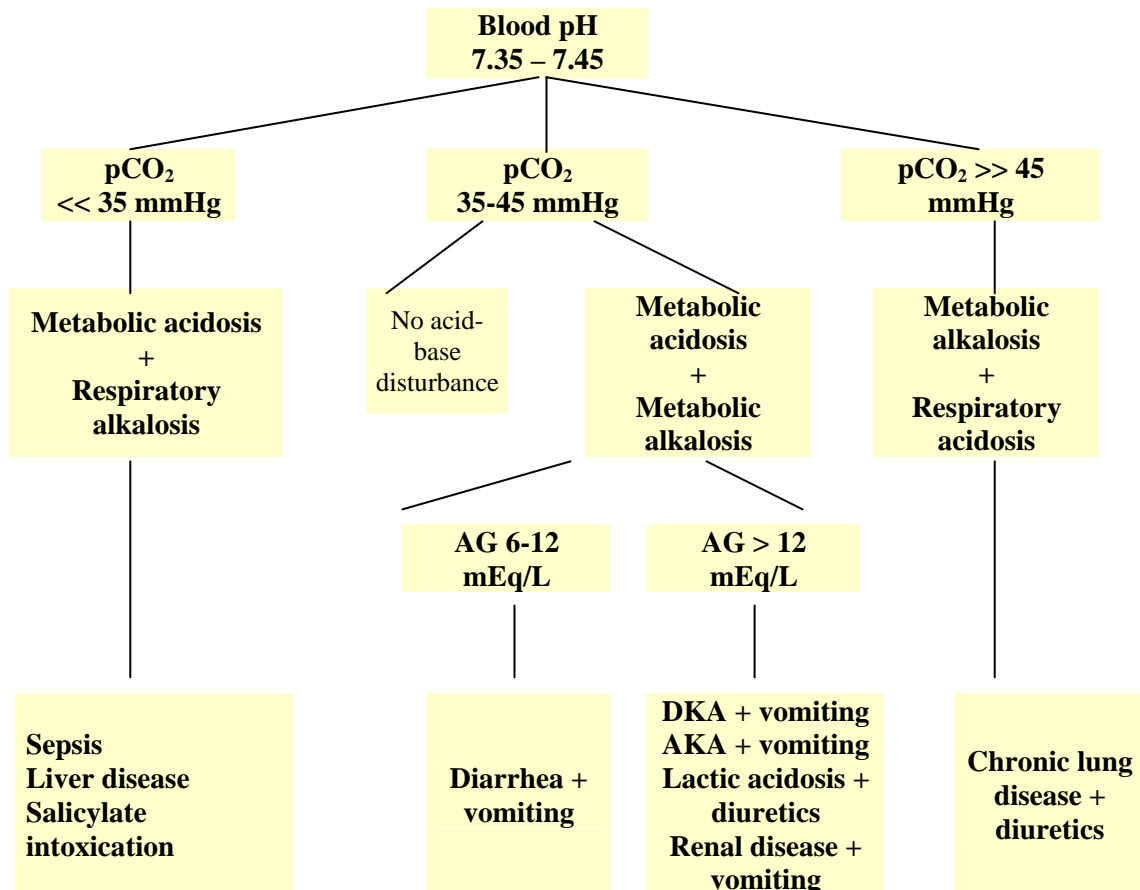

## References:

1. B.D. Rose: *Clinical physiology of acid-base and electrolyte disorders*. McGraw-Hill Health Professions Division 2001
2. Harrison's Principles of Internal Medicine. 14<sup>th</sup> ed. McGraw-Hill. 1998.
3. Henry J.B. *Clinical Diagnosis and Management by Laboratory Methods*. 19<sup>th</sup> ed. W.B. Saunders Company. Philadelphia 1996.
4. Ravel R. *Clinical Laboratory Medicine. Clinical Application of Laboratory Data*. 6<sup>th</sup> ed. Mosby-Year Book. 1995.

## Diagnostic approach to water-electrolyte disturbances

*Waldemar Myszka MD*

**The following are required to assess water and electrolyte status of a patient**

**Past history**

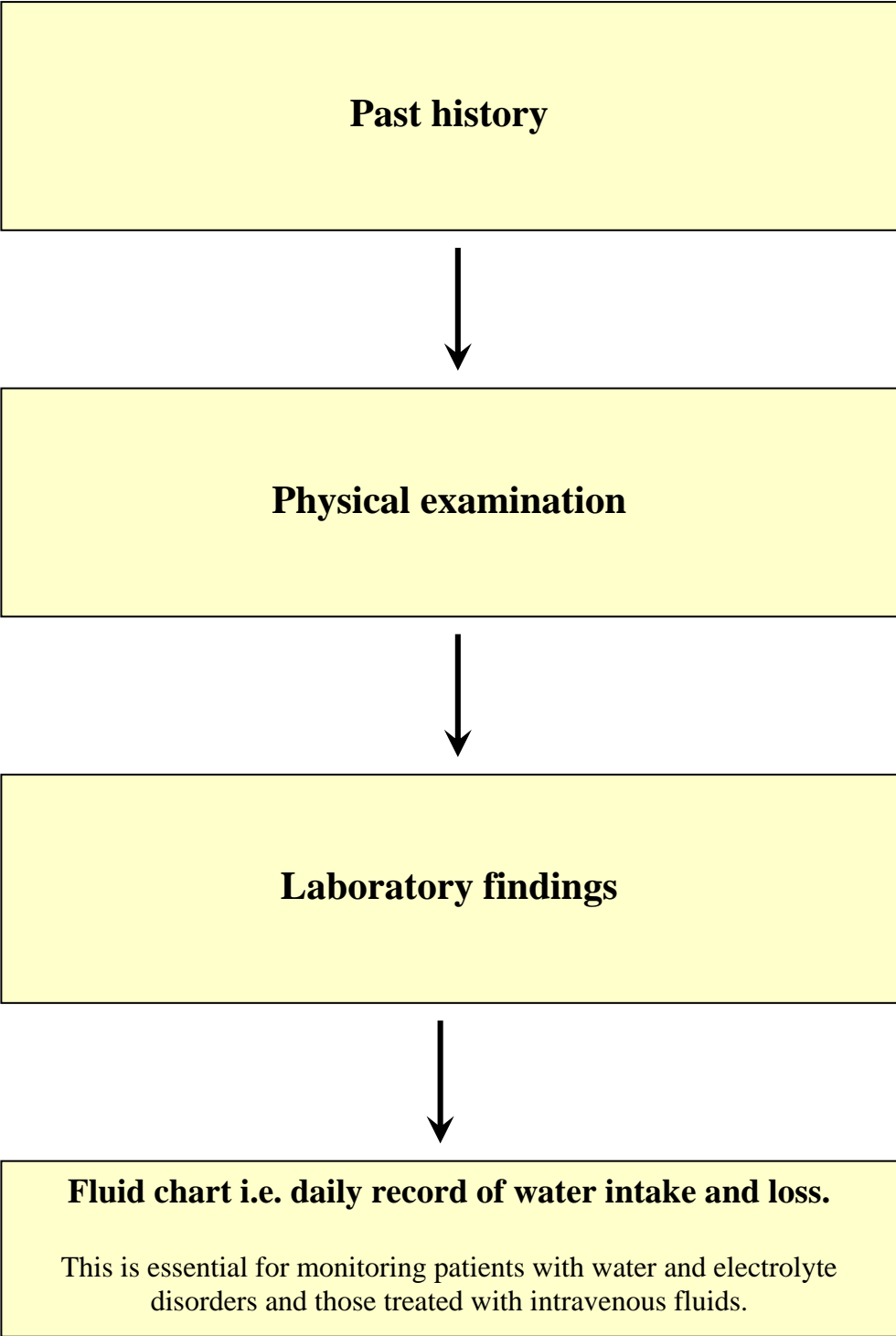

```
graph TD; A[Past history] --> B[Physical examination]; B --> C[Laboratory findings]; C --> D["Fluid chart i.e. daily record of water intake and loss. This is essential for monitoring patients with water and electrolyte disorders and those treated with intravenous fluids."];
```

**Physical examination**

**Laboratory findings**

**Fluid chart i.e. daily record of water intake and loss.**

This is essential for monitoring patients with water and electrolyte disorders and those treated with intravenous fluids.

**Laboratory tests that are useful in the diagnosis of water-electrolyte balance disorders  
– reference values**

<b>Blood (plasma)</b>		<b>Urine</b>
<b>Electrolytes</b>	<b>Na<sup>+</sup></b> – 135-145 mmol/l <b>K<sup>+</sup></b> – 3.5-5.0 mmol/l <b>Cl<sup>-</sup></b> – 98-107 mmol/l <b>HCO<sub>3</sub><sup>-</sup></b> – 21-26 mmol/l <b>Ca</b> – 2.12-2.62 mmol/l (8.5-10.5 mg/dl) <b>Ca<sup>2+</sup></b> – 0.98-1.13 mmol/l <b>Mg<sup>2+</sup></b> – 0.8-1.0 mmol/l (1.9-2.5 mg/dl) <b>PO<sub>4</sub><sup>2-</sup></b> – 0.97-1.45 mmol/l (3.0-4.5 mg/dl)	<b>Electrolytes</b>  <u>Daily excretion</u> <b>Na<sup>+</sup></b> – 80-240 mmol/l <b>K<sup>+</sup></b> – 25-80 mmol/l <b>Cl<sup>-</sup></b> – 110-260 mmol/l
<b>Kidney function</b>	<b>Urea</b> – 2.5-6.4 mmol/l (15-39 mg/dl) <b>BUN</b> – 7-18 mg/dl <b>Creatinine</b> – 62-124 μmol/l (0.7-1.4 mg/dl)	
<b>Acid-base status</b>	<b>pH</b> – 7.35-7.45 <b>pO<sub>2</sub></b> – 8.7-12.7 kPa (65-95 mmHg) <b>pCO<sub>2</sub></b> – 4.8-6.0 kPa (35-45 mmHg) <b>HCO<sub>3</sub><sup>-</sup></b> – 22-26 mmol/l <b>BE</b> – ± 2.5 mmol/l	
<b>CBC</b>	<b>HGB</b> – M: 14-18 g/dl, F: 12-16 g/dl <b>HCT</b> – M: 42-52 %, F: 37-47% <b>RBC</b> – M: 4.7-6.1 x10 <sup>12</sup> /l , F: 4.2-5.4 x10 <sup>12</sup> /l <b>MCV</b> – M: 80-94 fl, F: 81-99 fl <b>MCH</b> – M: 27-31 pg, F: 27-31 pg <b>MCHC</b> – M: 33-37 g/dl, F: 33-37 g/dl <b>WBC</b> – M: 4.8-10.8 x 10 <sup>9</sup> /l, F: 4.8-10.8x 10 <sup>9</sup> /l <b>PLT</b> – 130-400x10 <sup>9</sup> /l	
<b>Other biochemical tests</b>	<b>Protein (total)</b> – 60-80 g/l <b>Albumin</b> – 35-50 g/l <b>Glucose</b> – 65-110 mg/dl	

### Electrolyte content of body fluids

	<b>Na<sup>+</sup> mEq/L</b>	<b>K<sup>+</sup> mEq/L</b>	<b>Cl<sup>-</sup> mEq/L</b>	<b>HCO<sub>3</sub><sup>-</sup> mEq/L</b>
<b>Plasma</b>	142	4.5	102	26
<b>Saliva</b>	33	20	34	0
<b>Gastric juice</b>	60	9	84	0
<b>Bile</b>	149	4.9	101	45
<b>Pancreatic juice</b>	141	4.6	77	92
<b>Small bowel</b>	105	5.1	99	50
<b>Ileal fluid</b>	129	11.2	116	29
<b>Fecal fluid</b>	80	21	48	22
<b>Cerebrospinal fluid</b>	141	2.9	127	23
<b>Sweat</b>	45	4.5	58	0

### Approximate electrolyte content in mEq/L of carbohydrate and saline solutions

Solution	Na <sup>+</sup>	Cl <sup>-</sup>	mOsm/L
<b>Saline solution</b>			
0.45%	<b>77</b>	<b>77</b>	<b>154</b>
0.9%	<b>154</b>	<b>154</b>	<b>308</b>
3%	<b>513</b>	<b>513</b>	<b>1026</b>
<b>Dextrose in water</b>			
5%			<b>253</b>
10%			<b>505</b>
20%			<b>1010</b>
40%			<b>2526</b>
70%			<b>3536</b>
<b>Dextrose in saline</b>			
5% in 0.22%	<b>38</b>	<b>38</b>	<b>330</b>
5% in 0.45%	<b>77</b>	<b>77</b>	<b>406</b>
5% in 0.9%	<b>154</b>	<b>154</b>	<b>559</b>

### Concentration of ions in mEq/L of polyionic solutions

Solution	Na <sup>+</sup>	K <sup>+</sup>	Ca <sup>2+</sup>	Cl <sup>-</sup>	HCO <sub>3</sub> <sup>-</sup> precursor
Ringer's lactated	147	4	5	156	-
Hartmann's	130	4	3	109	28

### Potassium content in 1 mL of chosen potassium preparations

Potassium chloride 1-3 mEq/mL

Potassium acetate 2-4 mEq/mL

Potassium phosphate 2 mEq/mL

### Concentration of ions in alkalizing preparations (in mEq/L)

Solution	Na <sup>+</sup>	HCO <sub>3</sub> <sup>-</sup>
Sodium bicarbonate 1.96%	150	150
Sodium bicarbonate 8.4%	1000	1000

## Disorders of water-sodium balance

### Disorders of water balance

Disorders of water balance are reflected in changes of osmolality

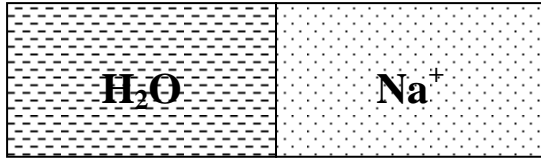

$Na^+$  135 – 145 mmol/l  
 $P_{Osm}$  285 – 295 mOsm/kg $H_2O$

Normally there is such a proportion of water to sodium in the extracellular fluid (ECF) that sodium concentration in that compartment ranges from 135 to 145 mmol/l. As sodium is the most abundant cation in the ECF it is responsible for plasma osmolality which in this case ranges from 285 to 295 mOsm/kg $H_2O$

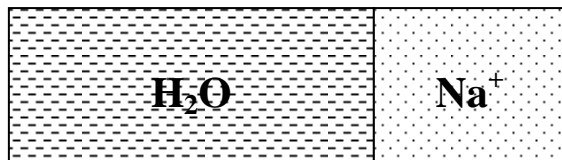

$Na^+ < 135$  mmol/l  
 $P_{Osm} < 285$  mOsm/kg $H_2O$

The relative water excess leads to Na dilution. Sodium concentration decreases and the state of hyponatremia ( $Na < 135$  mol/l) and hypoosmolality ( $< 270$  mOsm/kg $H_2O$ ) develops.

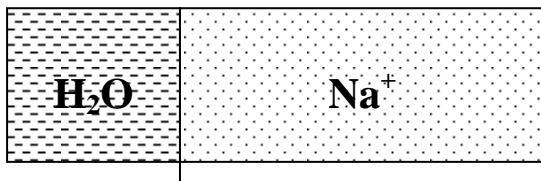

$Na^+ > 145$  mmol/l  
 $P_{Osm} > 295$  mOsm/kg $H_2O$

Water depletion leads to relative excess of sodium. Its concentration rises and the state of hypernatremia ( $Na^+ > 145$  mmol/l) and hyperosmolality ( $P_{Osm} > 295$  mOsm/kg $H_2O$ ) develops.

### Disorders of sodium balance

Disorders of sodium balance are reflected in changes of extracellular fluid (ECF) volume

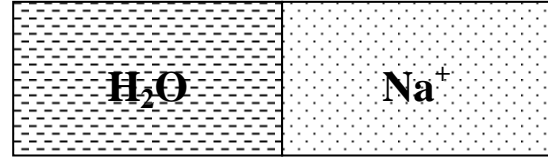

ECF – Normal

Normally there is such an amount of sodium in the organism that ECF volume is normal means a patient is euvolemic

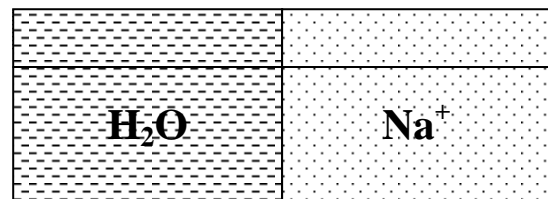

ECF - Expanded

When sodium is retained in the organism (water is also retained concomitantly) the ECF volume rises and oedema develops.

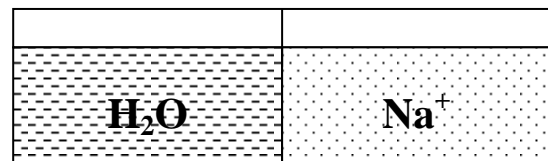

ECF – Decreased

When sodium is lost from the organism (concomitantly with water) the ECF volume decreases and hypovolemia develops.

## Clinical manifestation of water-sodium balance disorders

Symptoms of hypernatremia	Symptoms of hyponatremia
Disorientation	Weakness
Lethargy that progress to coma	Hyporeflexia or hyperreflexia
Increased deep tendon reflexes	Anorexia
Muscle weakness	Muscular twitches
Muscle rigidity	Exhaustion
Tremor	General rigidity
Myoclonus	Headache
Convulsions	Convulsions
	Disorientation
	Nausea
	Lethargy
	Vomiting
	Confusion
	Light-headedness

Low extracellular fluid (ECF) volume (hypovolemia)	Expanded extracellular fluid volume (overhydration)
Dry mucous membranes	Neck vein distention
Decreased skin turgor	Increased central venous pressure
Soft and contracted eyes	Edema
Flattened neck veins	Ascites
Low blood pressure	Congestive heart failure
Postural changes in blood pressure	Basal crepitations
Increased heart rate	
Low central venous pressure	
Dry shrunken tongue with deep furrows	



## Normonatremia with expanded ECF

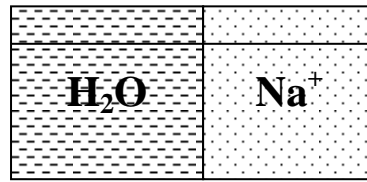

Expanded ECF

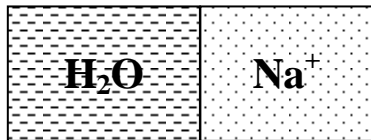

$\text{Na}^+$  135 – 145 mmol/l  
 $P_{\text{Osm}}$  285 – 295 mOsm/kg $\text{H}_2\text{O}$

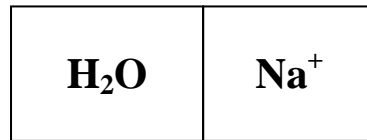

Normal ECF

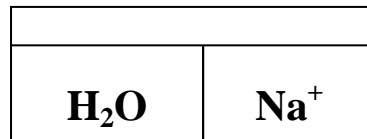

Decreased ECF

$\text{Na}^+$  and water is retained in the organism, but both substances are gained proportionally so the sodium concentration and plasma osmolality doesn't change. Retention of sodium and water in the ECF leads to cardinal manifestation of the disorder – oedema.

### The most common causes (clinical history):

- Congestive heart failure
- Cirrhosis of the liver
- Nephrotic syndrome
- Administration of  $\text{Na}^+$  containing isotonic fluids (in excess)

### Clinical manifestation (physical examination):

- Symptoms of expanded ECF (see above)
- Symptoms of underlying disorder

### Laboratory tests:

- Blood: Plasma sodium concentration, plasma osmolality, BUN, plasma creatinine concentration, CBC.  
(Other specific for the underlying disease)
- Urine: Urine sodium concentration, urine osmolality, urine output.

## Normonatremia with decreased ECF

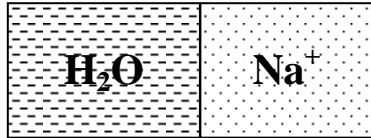

$\text{Na}^+$  135 – 145 mmol/l  
 $P_{\text{Osm}}$  285 – 295 mOsm/kg<sub>H<sub>2</sub>O</sub>

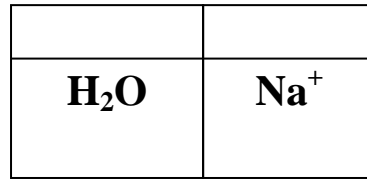

Expanded ECF

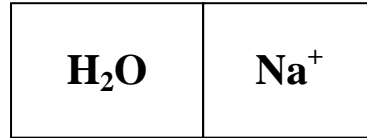

Normal ECF

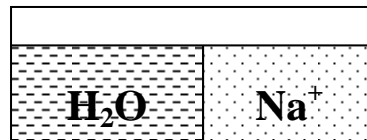

Decreased ECF

$\text{Na}^+$  is lost from the organism with an isotonic fluid so there is no alteration in the plasma osmolality but ECF volume decreases and hypovolemia develops.

### The most common causes (clinical history):

- Bleeding
- Diarrhea

### Clinical manifestation (physical examination):

- Symptoms of underlying disorder
- Symptoms of hypovolemia

### Laboratory tests:

- Blood: Plasma sodium concentration, plasma osmolality, BUN, plasma creatinine concentration, CBC.  
(*Other specific for the underlying disease*)
- Urine: Urine sodium concentration, urine osmolality, urine output.

**Regulation of plasma osmolality – hyperosmolality caused by water loss**

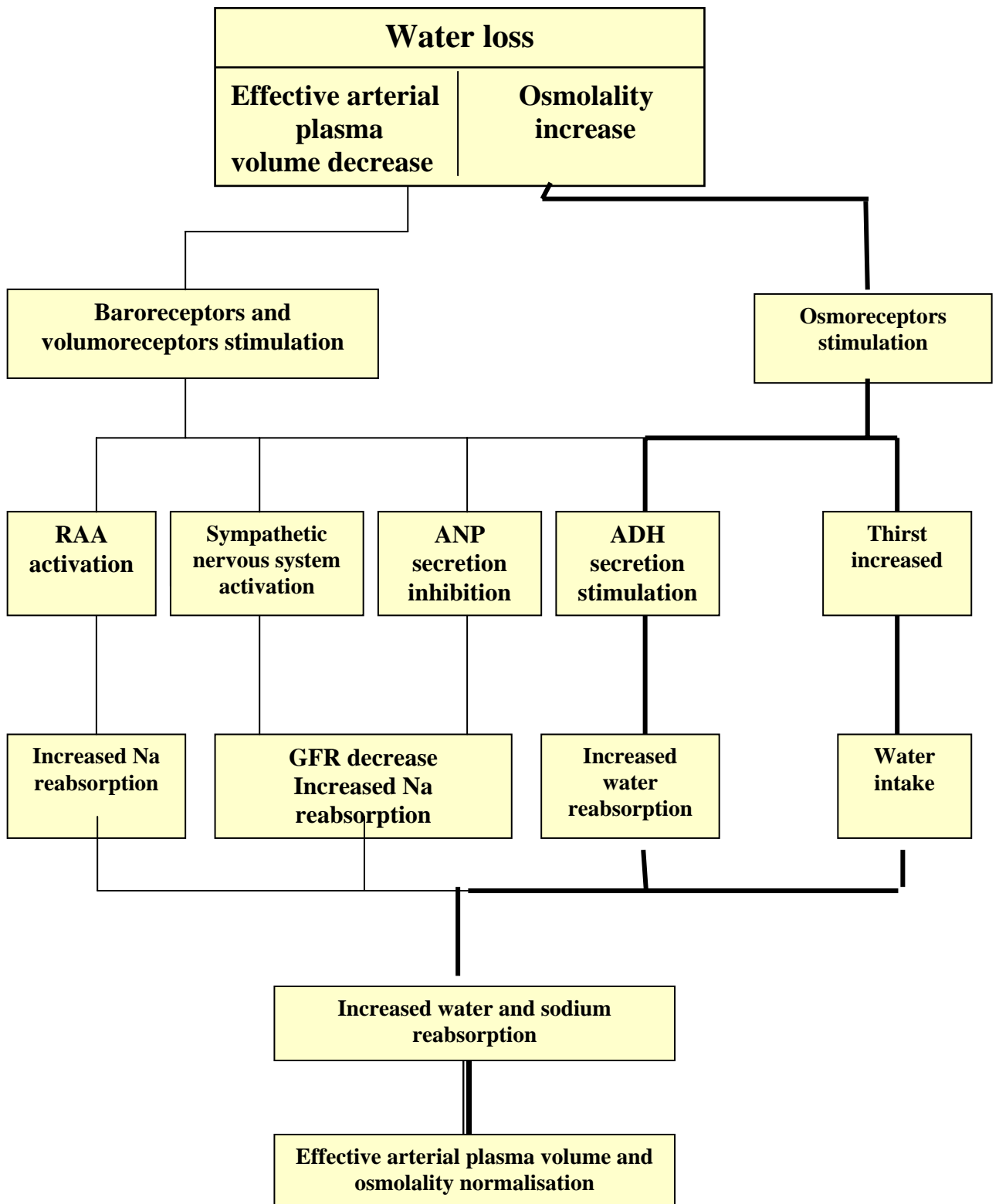

## Hypernatremia with decreased ECF

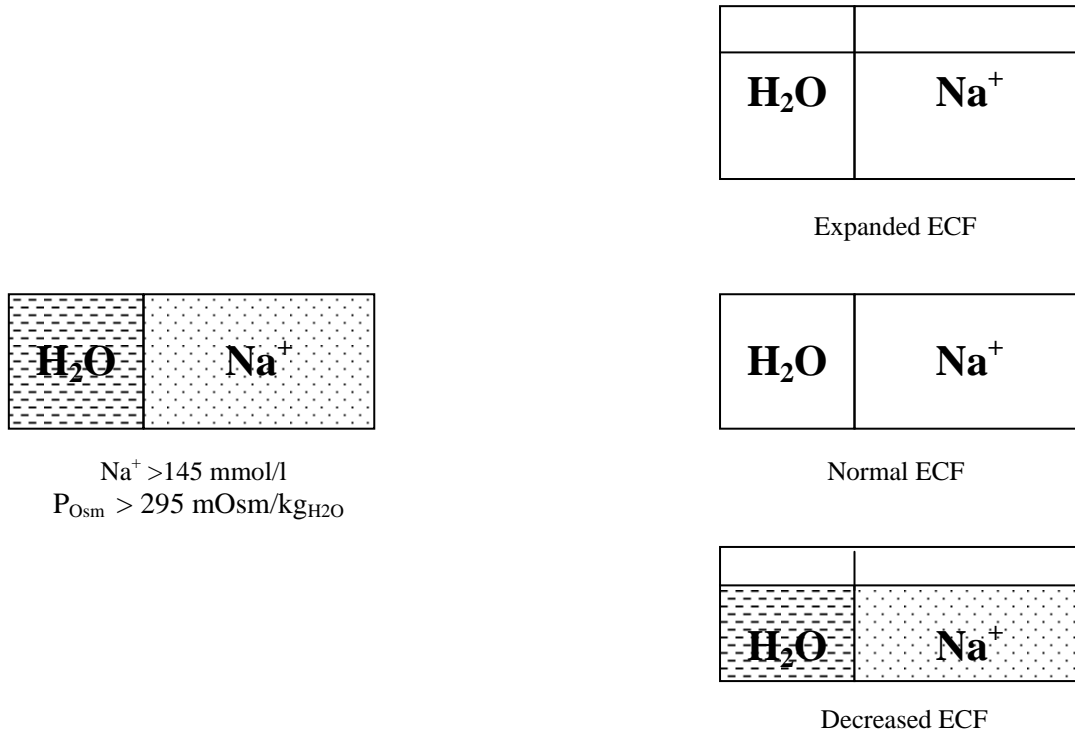

Water and sodium is lost as a hypotonic fluid. Relatively more water than sodium is lost resulting in the rise of the sodium concentration.

### The most common causes (clinical history):

- extrarenal water loss
  - osmotic diarrheas (induced by lactulose, sorbitol, malabsorption of carbohydrate), vomiting, sweating, burns
- renal water loss
  - osmotic diuresis (glucose, mannitol, urea), diuretics

### Clinical manifestation (physical examination):

- Symptoms of the underlying disorder
- Symptoms of hypovolemia
- Symptoms of hypernatremia

### Laboratory tests:

- Blood: Plasma sodium concentration, plasma osmolality, BUN, plasma creatinine concentration, Ht, plasma protein concentration.  
*(Other specific for the underlying disease)*
- Urine: Urine sodium concentration, urine osmolality, urine output.

## Hypernatremia with normal ECF

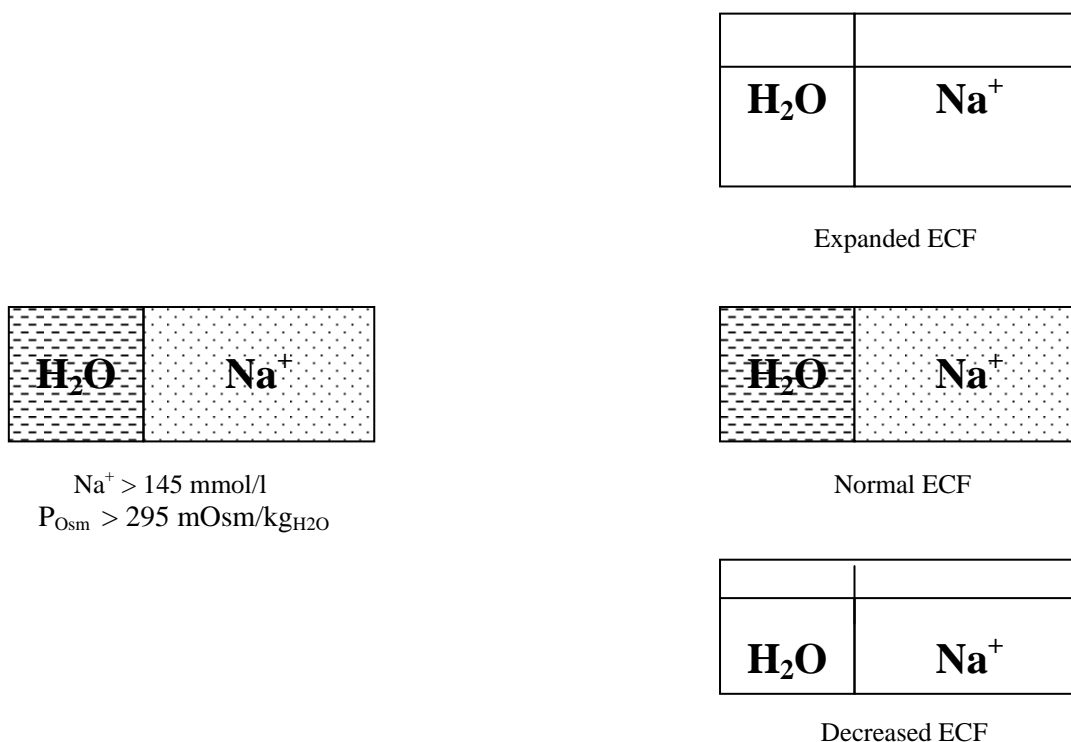

Water is lost from the organism as “pure” water without or with only a small amount of electrolytes, that is why a state of relative excess of  $\text{Na}^+$  develops and its concentration rises. As water flows continuously from cells to the ECF because of osmotic gradient, ECF volume is not decreased for the very long time and the symptoms of hypovolemia are not present.

### The most common causes (clinical history):

- extrarenal water loss
  - increased insensible water loss (fever, hot and dry environment, thyrotoxicosis, hyperventilation)
- renal water loss
  - central or nephrogenic diabetes insipidus

Note: certain believe that there are examples of a state with low ECF because of the fact that dehydration may develop. In fact hypovolemia and dehydration always develops in that case if only a patient doesn't intake sufficient amount of fluid which match the water loss.

### Clinical manifestation (physical examination):

- Symptoms of hypernatremia (usually mild)

### Laboratory tests:

- Blood: Plasma sodium concentration, plasma osmolality, BUN, plasma creatinine concentration, Ht, plasma protein concentration.  
(Other specific for the underlying disease)
- Urine: Urine sodium concentration, urine osmolality, urine output.

## The most common causes of diabetes insipidus

### Causes of hypothalamic diabetes insipidus

Head trauma

Postsurgical (hypophysectomy)

Tumors

Craniopharyngioma, pinealoma, meningioma, germinoma, glioma  
benign cysts, leukemia/lymphoma, metastatic tumors

Infections

Tuberculosis, syphilis, mycoses, toxoplasmosis, encephalitis, basilar meningitis

Granulomatous diseases

Sarcoidosis, histiocytosis X/ eosinophilic granuloma, Wegener's disease

Cerebrovascular disease

Aneurysms, cavernous sinus thrombosis, postpartum pituitary infarction (Sheehan's syndrome), cerebrovascular accident

Idiopathic

Sporadic, familial

### Causes of nephrogenic diabetes insipidus

#### Congenital

Vasopressin  $V_2$  – receptor mutations, aquaporin –2 water channel mutations

#### Acquired

Medications

Lithium, Amphotericin B, Demeclocycline, Methoxyflurane

Obstructive uropathy

Chronic tubulointerstitial diseases

Analgesic abuse nephropathy, sickle cell nephropathy, multiple myeloma, amyloidosis, sarcoidosis, Sjogren's syndrome. Polycystic kidney disease, medullary cystic disease

Electrolyte disorders

Hypercalcemia, potassium depletion

## Hypernatremia with expanded ECF

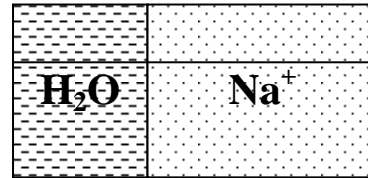

Expanded ECF



$\text{Na}^+ > 145 \text{ mmol/l}$   
 $P_{\text{Osm}} > 295 \text{ mOsm/kg}_{\text{H}_2\text{O}}$

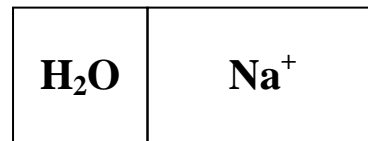

Normal ECF

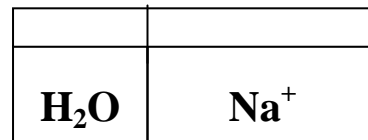

Decreased ECF

### The most common causes (clinical history):

- Administration of concentrated sodium solutions e.g. concentrated sodium bicarbonate
- Ingestion of sea water
- Salt inadvertently used instead of sugar

### Clinical manifestation (physical examination):

- Symptoms of hypernatremia
- Symptoms of hypervolemia– central (pulmonary) oedema. *Hyperosmolality causes water flow from the interstitial space that is why circulating blood volume rises leading to congestive heart failure.*

### Laboratory tests:

- Blood: Plasma sodium concentration, plasma osmolality, BUN, plasma creatinine concentration, Ht, plasma protein concentration.  
(*Other specific for the underlying disease*)
- Urine: Urine sodium concentration, urine osmolality, urine output.

# Hypernatremia

Fluid volume status assessed by physical examination

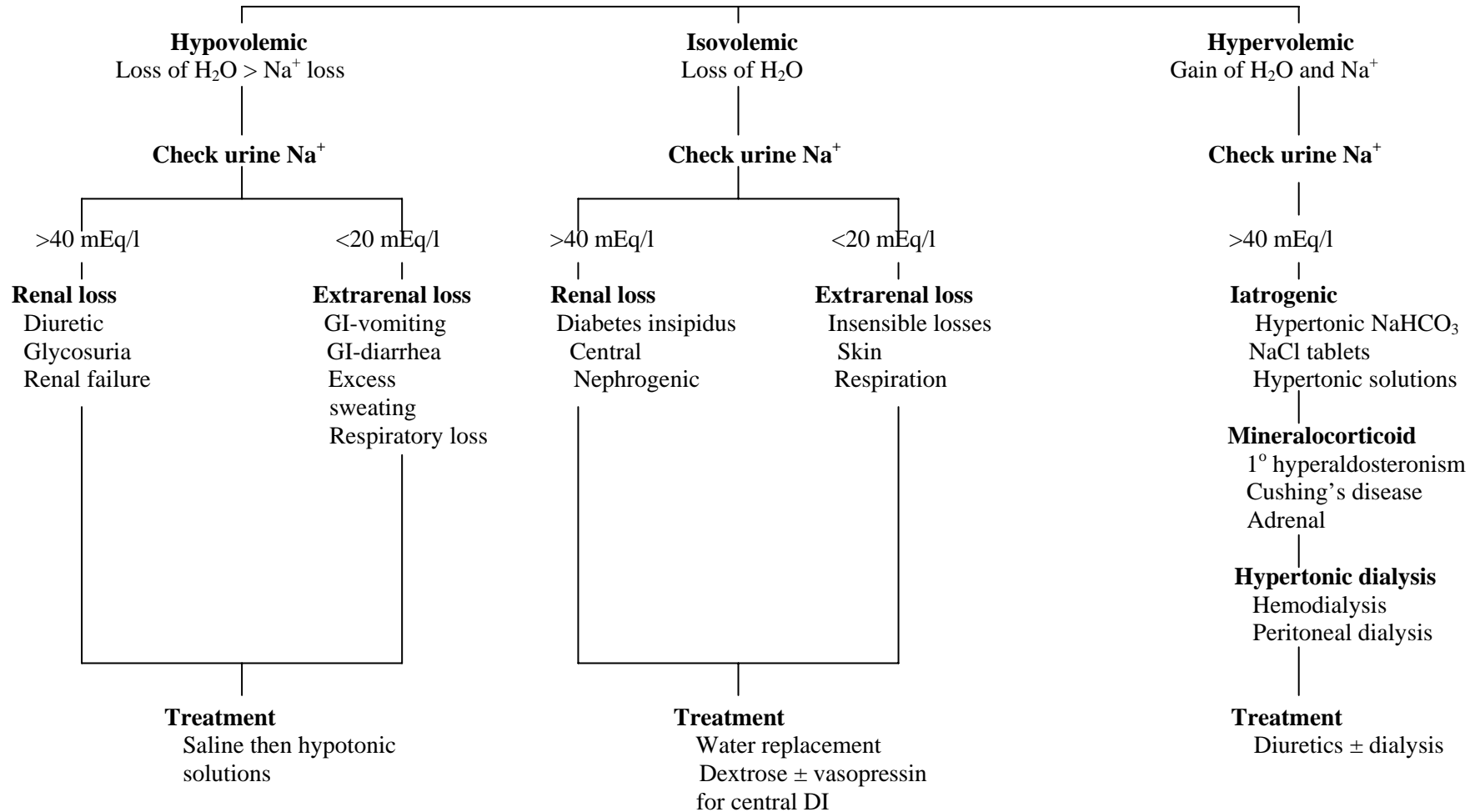



## Principles of treatment of hypernatremia

1. Free water deficit =  $0.5 \times \text{body weight} \times [(\text{plasma sodium}/140) - 1]$
2. In acute hypernatremia, the water deficit can be replaced relatively rapidly. One half of the calculated water deficit can be replaced during the first 12 hours (plasma sodium concentration should then decrease by 1 to 2 mmol/l/h), and then the rate of correction slowed so that the sodium is normalized over the ensuing 24 to 48 h.
3. Although no definitive trials have been performed, in the case of chronic hypernatremia, observations suggest that the maximum safe rate at which the plasma sodium concentration should be lowered is 0.5 mmol/l per hour or 12 mmol/l per day.
4. In addition to replacing the calculated water deficit, ongoing fluid losses and basal requirements must also be replaced. If possible the cause of the increased losses should be addressed.
5. Free water can be given orally or intravenously (as dextrose in water) to patients with hypernatremia due to pure water loss.
6. An infusion of quarter-isotonic saline is preferable if  $\text{Na}^+$  depletion is also present as typically occurs with concurrent vomiting, diarrhea or diuretic use.
7. When using glucose containing solutions, the glucose level should be monitored because hyperglycemia worsens to hyperosmolality and can lead to osmotic diuresis.
8. Deterioration in neurologic symptoms after initial improvement suggests the development of cerebral oedema and requires temporary discontinuation of water replacement.
9. In patients with volume depletion, therapy should aim first at restoring intravascular volume and then at correcting the water deficit. (Normal saline, plasma, whole blood or other volume expanders may be used)
10. In patients with hypernatremia secondary to solute administration, the hypernatremia is acute and can be rapidly corrected. These patients usually are volume overloaded and require both water administration and solute removal. A loop diuretic can be administered along with water to facilitate sodium excretion.
11. In patients with massive volume overload or renal failure, dialysis may be necessary.

## Disorders of water-sodium balance present with hyponatremia

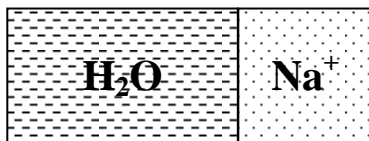

$Na^+ < 135 \text{ mmol/l}$   
 $P_{Osm} < 285 \text{ mOsm/kg}_{H_2O}$

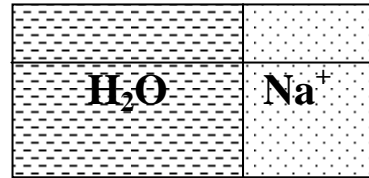

Expanded ECF

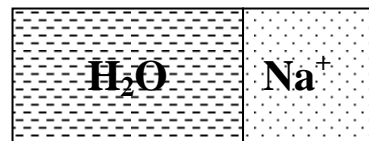

Normal ECF

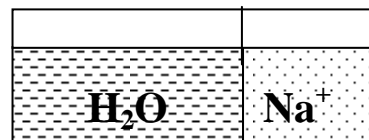

Decreased ECF

**Hyponatremia and hypoosmolality develops as a result of water retention in the organism.**

**Note: the state of hypoosmolality and hyponatremia usually does not develop until two conditions are met:**

- 1. water intake**
- 2. excess of ADH (which unable water excess to be excreted)**

## Regulation of plasma osmolality – hypoosmolality caused by water retention

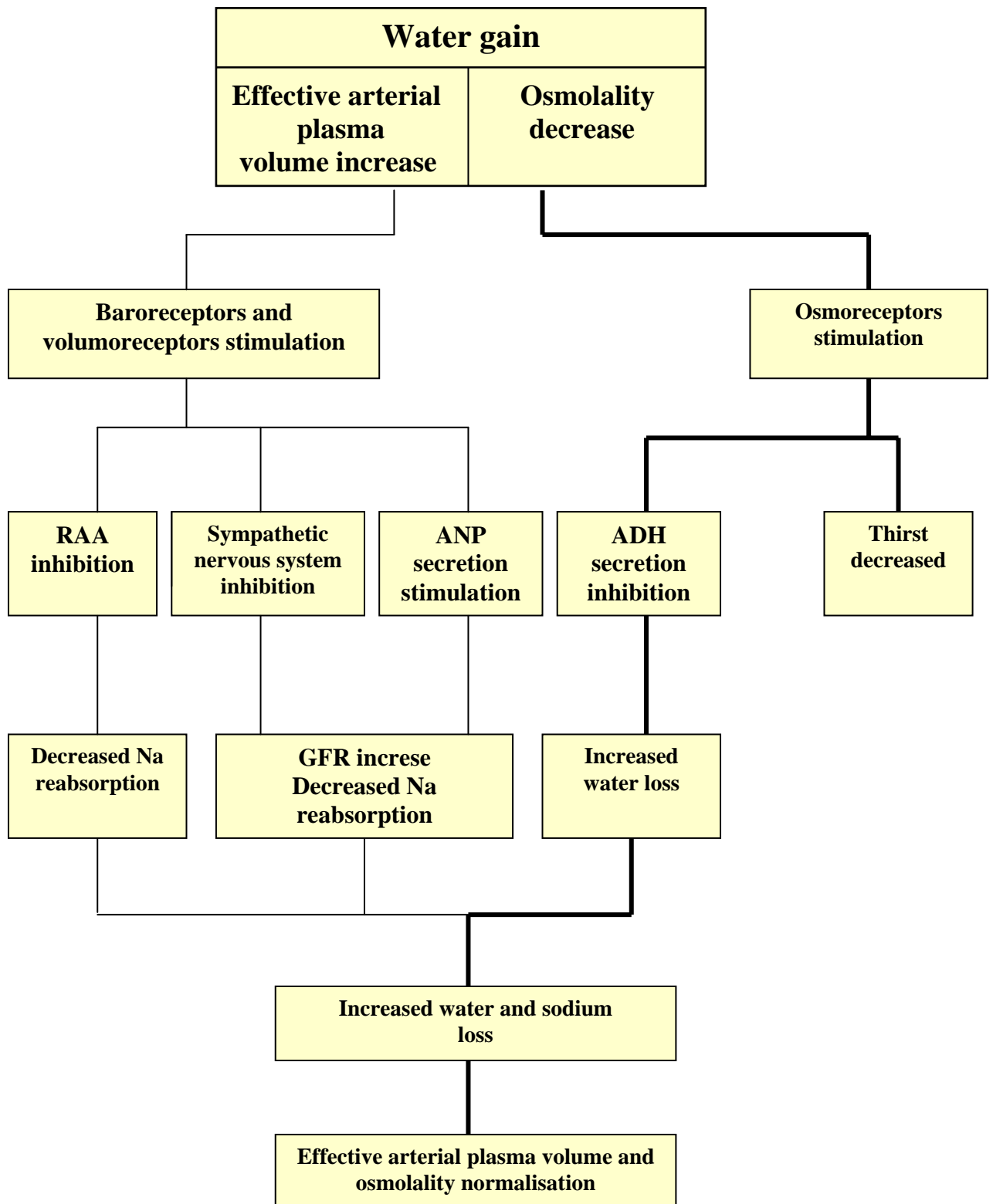

## Hyponatremia and expanded ECF

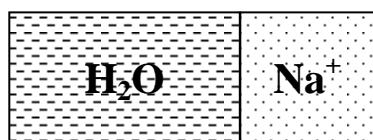

$\text{Na}^+ < 135 \text{ mmol/l}$   
 $P_{\text{Osm}} < 285 \text{ mOsm/kgH}_2\text{O}$

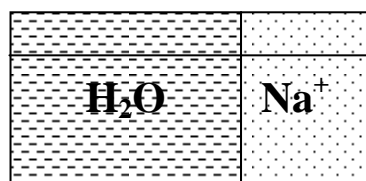

Expanded ECF

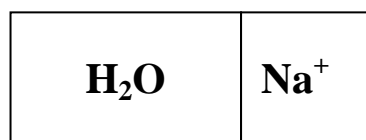

Normal ECF

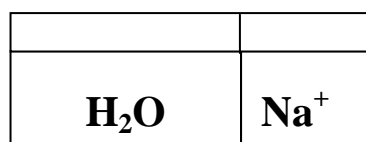

Decreased ECF

Water and sodium is retained (because of underlying disease), but relatively more water than sodium is gained. ECF volume rises as a result of sodium retention, but its concentration decreases as a result of retention of water.

### The most common causes (clinical history):

- Congestive heart failure
- Cirrhosis of the liver
- Nephrotic syndrome

**Note:** in the patients with one of that disease oedema is usually present but  $\text{Na}^+$  concentration is usually normal. The factor responsible for the development of oedema is low ejection fraction (EF) in congestive heart failure and hypoproteinemia in patients with liver and kidney diseases – the disorders leading to low effective circulating blood volume which is a stimulus for ADH secretion. ADH is released but the amount of water retained in the circulation is too low to cause hyponatremia. When the underlying disorder begun more severe decrease of EF or further decrease of protein concentration may lead to enhanced secretion of ADH resulting in water retention and hyponatremia.

### Clinical manifestation (physical examination):

- Symptoms of the underlying disease
- Symptoms of hypervolemia
- Symptoms of hyponatremia

### Laboratory tests:

- Blood: Plasma sodium concentration, plasma osmolality, BUN, plasma creatinine concentration, Ht, plasma protein concentration.  
(Other specific for the underlying disease)
- Urine: Urine sodium concentration, urine osmolality, urine output.

## Hyponatremia with normal ECF

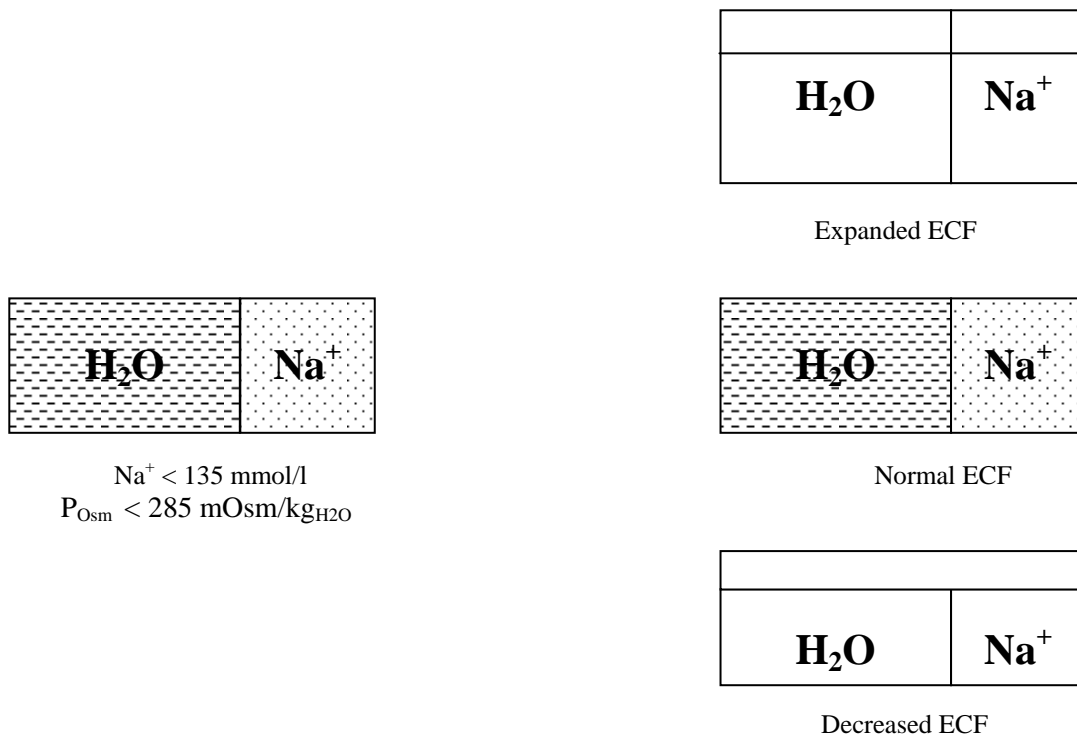

Water is retained in the amount sufficient to cause  $\text{Na}^+$  concentration decrease but ECF volume doesn't rise because sodium metabolism is not altered. Sodium is excreted properly via the kidney, is not retained in the organism that is why clinically important oedema doesn't develop.

As hyponatremia in that situation is usually not severe patients are asymptomatic until enhanced water ingestion or administration take place. As ADH is in excess and water can't be excreted, acute water intoxication may develop.

### The most common causes (clinical history):

- **Acute hyponatremia (Acute water intoxication) – rapid administration of water plus**
  - Acute hypovolemia (e.g. haemorrhage)
  - During early postoperative period
  - During labour and delivery
  - Schizophrenia
  - In the presence of a chronic cause of impaired water excretion (see below)
- **Chronic hyponatremia**
  - Primary polydipsia
  - Decreased solute intake (beer potomania)
  - Antidiuretic drug administration
  - Syndrome of inappropriate AVP secretion (SIADH)
  - AVP release due to pain, nausea, drugs
  - Glucocorticoid deficiency
  - Anterior hypopituitarism
  - Abrupt withdrawal of glucocorticoid drug therapy
  - Severe hypothyroidism
  - Chronic renal insufficiency

**Clinical manifestation (physical examination):**

- Symptoms of the underlying disorder (if present)
- Symptoms of hyponatremia

**Symptoms of acute hyponatremia**

**Mild hyponatremia (sodium > 125 mmol/L) is usually asymptomatic.**

**Sodium < 125 mmol/L**

- weakness
- exhaustion

**Sodium < 120 mmol/L**

- headache
- nausea
- vomiting
- anorexia
- disorientation
- lethargy
- pathological deep tendon reflexes

**Sodium < 110 mmol/L**

- papilledema and other manifestations of increased intracranial pressure
- seizures
- coma

*There is a poor correlation between the severity of symptoms and the degree of chronic hyponatremia, reflecting variable degrees of brain adaptation.*

**Laboratory tests:**

- Blood: Plasma sodium concentration, plasma osmolality, BUN, plasma creatinine concentration, CBC.  
(Other specific for the underlying disease)
- Urine: Urine sodium concentration, urine output, urine osmolality.

## SIADH

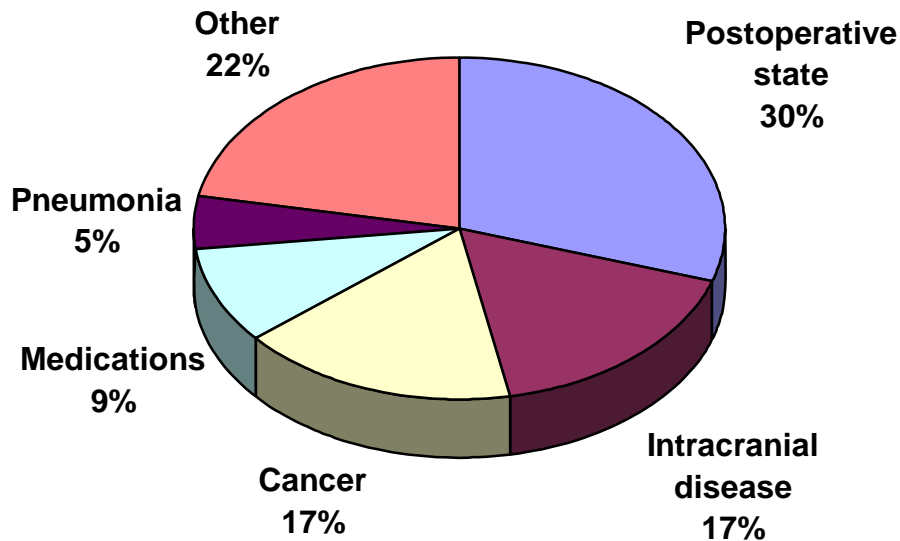

### Diagnostic criteria:

1. Hypotonic hyponatremia
2. Urine osmolality greater than 100 mOsm/kg<sub>H2O</sub>
3. Urine sodium concentration greater than 40 mmol/l (*unless the patient is volume depleted for some other reason*)
4. Absence of extracellular volume depletion or expansion
5. Normal thyroid and adrenal function
6. Normal cardiac, hepatic and renal function

## Hyponatremia with low ECF

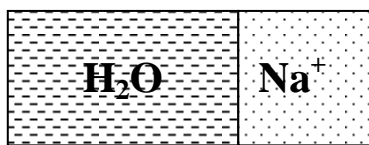

$Na^+ < 135 \text{ mmol/l}$   
 $P_{Osm} < 285 \text{ mOsm/kg}_{H_2O}$

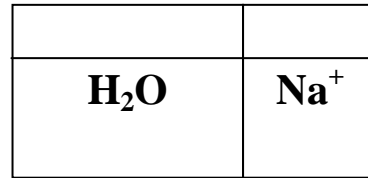

Expanded ECF

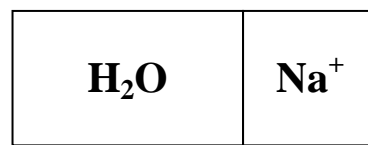

Normal ECF

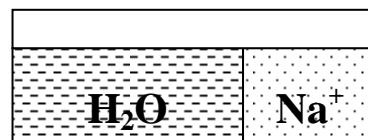

Decreased ECF

That state is usually the result of improper treatment of hypovolemia present with normal or low osmolality. When a patient is losing isotonic or hypotonic fluid is losing water and electrolytes. When fluid losses are replaced only with nonelectrolytes fluids (dextrose solutions) than most water load flows into the cells, with only 1/3 left in the ECF. Administrations of pure water cause decrease of sodium concentration but usually doesn't cause the restoration of the ECF volume that is why hypovolemia is still present.

### The most common causes (clinical history):

- Extensive sweating, burns
- Gastrointestinal loss: vomiting, tube drainage, fistula, obstruction, diarrhoea
- Renal loss: diuretics, osmotic diuresis, hypoaldosteronism, salt-wasting nephropathy, postobstructive diuresis

### Clinical manifestation (physical examination):

- Symptoms of underlying disorder
- Symptoms of hypovolemia (usually mild)
- Symptoms of hyponatremia (usually mild)

### Laboratory tests:

- Blood: Plasma sodium concentration, plasma osmolality, BUN, plasma creatinine concentration, Ht, plasma protein concentration.  
*(Other specific for the underlying disease)*
- Urine: Urine sodium concentration, urine osmolality, urine output.



# Hyponatremia

Serum osmolality

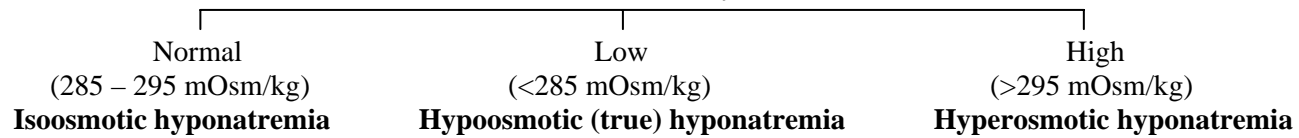

Pseudohyponatremia  
Hyperlipidemia  
Hyperproteinemia  
Isotonic infusions  
Mannitol Sorbitol  
Glycine Ethanol

Hyperglycaemia  
Hypertonic infusions  
Glucose Glycerol  
Mannitol Sorbitol  
Glycine Ethanol

Urine osmolality

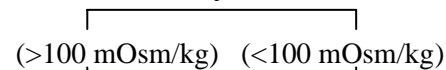

Impaired renal water excretion

Extensive water intake (polydipsia)

Assess extracellular fluid volume state

Low ECF

Normal ECF

Expanded ECF

Urine Na<sup>+</sup>

Urine Na<sup>+</sup>

Urine Na<sup>+</sup>

**< 20 mEq/l**  
Extrarenal  
GI-vomiting  
GI-diarrhea  
Pancreatitis  
Skin losses  
Lung losses

**>40 mEq/l**  
Renal  
Diuretic  
Obstruction  
Renal damage  
Renal tubular acidosis  
Adrenal insufficiency

**< 20 mEq/l**  
H<sub>2</sub>O intoxication

**>40 mEq/l**  
Renal failure  
Hypothyroid  
Pain  
SIADH  
Emotion  
Adrenal insufficiency

**< 20 mEq/l**  
Cirrhosis  
Heart failure  
Renal failure

**>40 mEq/l**  
Acute/Chronic renal failure

## Principles of treatment of severe hypotonic hyponatremia (Sodium < 120 mmol/L)

<b>Acute</b>	- with hypovolemia	0.9% NaCl, rapid correction 1 – 2 mmol/L/h during the first 6-8 hours, subsequently 0.5 mmol/L/h
	-with euvoemia	3% NaCl, rapid correction 1 – 2 mmol/L/h during the first 12 hours subsequently 0.5 mmol/L/h furosemide (monitoring of the serum sodium concentration hourly)
	-with oedema	hemodialysis with ultrafiltration or hemofiltration
<b>Chronic</b>	-with hypovolemia	0.9% NaCl, slow correction 0.5 mmol/L/h, potassium supplementation
	-with euvoemia	water restriction SIADH – demeclocycline potassium supplementation
	-with oedema	water and sodium restriction furosemide angiotensin converting enzyme inhibitors potassium supplementation

- *Acute hyponatremia* – symptomatic

- *Chronic hyponatremia* – asymptomatic

1. Asymptomatic or  $\geq 120$  mmol/l hyponatremia doesn't require aggressive treatment.
2. In acute hyponatremia sodium rise during the first 24-h should be less than 20 mmol/L (optimally 10-12 mmol/24 h).
3. In chronic hyponatremia sodium rise during the first 24-h should be no more than 10-12 mmol/L.
4. Desired sodium concentration during the first 24 h is 120-125 mmol/L (no 140 mmol/L).  
Sodium deficit =  $0.6 \times \text{body weight} \times (125 - P_{\text{Na}})$
5. When sodium concentration is restored to 120-125 mmol/L further normalization should be achieved during the next few days via fluid restriction.

## Causes of Hypokalemia

### Decreased intake

- Starvation
- Clay ingestion

### Redistribution into cells

- Metabolic alkalosis
- Insulin administration
- Beta2 adrenergic agonists (endogenous or exogenous)
- Alpha-adrenergic antagonists
- Vitamin B12 or folic acid (red blood cell production)
- Granulocyte-macrophage colony stimulating factor (white blood cell production)

### Increased loss

#### Nonrenal

- Gastrointestinal loss (diarrhea, vomiting)
- Integumentary loss (sweat)

#### Renal

- Increased distal flow: diuretics, osmotic diuresis, salt-wasting nephropathies
- Increased secretion of potassium
  - Mineralocorticoid excess: primary hyperaldosteronism, secondary hyperaldosteronism

## Symptoms of hypokalemia

Physical examination	ECG changes
<ul style="list-style-type: none"> <li>• Muscle weakness</li> <li>• Muscle cramps</li> <li>• Paresthesias</li> <li>• Muscular pains</li> <li>• Lethargy</li> <li>• Drowsiness</li> <li>• Confusion</li> <li>• Irritability</li> <li>• Postural hypotension</li> <li>• Anorexia</li> <li>• Nausea to vomiting</li> <li>• Abdominal cramps</li> </ul>	<ul style="list-style-type: none"> <li>• Depression of the ST segment</li> <li>• Lowering, flattening, or inversion of the T wave</li> <li>• Presence of an elevated U wave</li> <li>• Increase in P-wave amplitude</li> <li>• Prolongation of PR interval</li> <li>• Severe hypokalemia may prolong the QRS period by 0.1 to 0.3s., without changes in QRS configuration</li> <li>• Arrhythmias</li> </ul>

### Laboratory tests:

- Blood: Plasma potassium concentration, plasma osmolality, BUN, plasma creatinine concentration  
(*Other specific for the underlying disease*)
- Urine: Urine potassium excretion, urine output, urine osmolality.

# Hypokalemia

## Exclude redistribution

Alkalosis  
Insulin  
Periodic paralysis  
Barium poisoning  
Vitamin B<sub>12</sub> therapy

## Extrarenal K losses

Urine electrolytes excretion  
K < 20 mEq/day  
Na > 100 mEq/day  
*(If Na < 100 mEq/day repeat test after increasing dietary Na > 100 mEq/day)*  
Biliary losses  
Lower GI losses  
Fistulla  
Skin losses

## Renal K losses

Urine electrolytes excretion  
K > 20 mEq/day  
Na > 100 mEq/day

## High blood pressure

Plasma renin levels

### High plasma renin

Malignant HTN  
Renovascular disease  
Renin secreting tumor

### Low plasma renin

Aldosterone

#### High

Hyperaldosteronism  
Bilateral hyperplasia

#### Low

Mineralocorticoid ingestion  
Adrenal hyperplasia (congenital)  
Cushing's syndrome

## Normal or low blood pressure

Serum pH

### Low pH

RTA

### High pH

Urine chloride

#### < 10 mEq/day

Vomiting

#### > 10 mEq/day

Barter's syndrome  
Diuretics  
Magnesium deficiency

## Principles of potassium supplementation

1. The quantity of potassium for intravenous therapy may be difficult to ascertain because serum potassium may not reflect total body potassium.
2. A decrement of 1 mmol/L in the plasma potassium concentration (from 4.0 to 3.0 mmol/L) may represent a total body K deficit of 200 to 400 mmol, and patients with plasma levels under 3.0 mmol/L often require in excess of 600 mmol of K to correct the deficit.
  - if the serum potassium is less than 3 mEq/l, an infusion of 200 to 400 mEq of potassium is generally necessary to raise the serum K by 1 mEq/L
  - if serum potassium is between 3 and 4.5 mEq/L an infusion of 100-200 mEq/l will raise the serum potassium by 1 mEq/L.
3. The maximum concentration of administered K should be no more than 40 mEq/L via a peripheral vein or 60 mEq/L via a central vein.
4. The rate of infusion should not exceed 20 mEq/h.
  - If there are indications for urgent therapy, such as serum potassium less than 2.0 mEq/L, abnormal electrocardiogram, or paralysis, potassium may be infused at rates up to 40 mEq/h in concentrations not greater than 60 mEq/L. Up to 400 mEq KCl may be administered i.v. per day.
  - When plasma potassium concentration reaches 2.5 meq/L, the rate of administration should be slowed to 10 mEq/h, and solutions should contain no more than 30 mEq/L.
  - If serum potassium is greater than 2.5 mEq/l and the electrocardiographic disturbances of hypokalemia are absent, potassium should not be administered at rates greater than 10 mEq/h or in concentrations above 30 mEq/L. Not more than 100 to 200 mEq/day should be given.
5. Whenever potassium is infused, it must first be determined that the patient is not hyperkalemic or oliguric, and adequacy of renal function should be established (e.g., by serum creatinine levels)
6. If the patient receives potassium at rates of 120 mEq/day or 20 mEq/h for more than 2h, the ECG should be monitored continuously and the serum potassium measured with each 50-100 mEq infused.
7. With severe hypokalemia, potassium should be infused in saline if there are no contraindications rather than in dextrose and water because infusion of glucose may further depress the serum potassium.
8. Potassium should never be infused as a bolus.
9. When potassium is added to an intravenous container, particularly a plastic nonrigid one, it may not mix well; and during intravenous administration it may enter the blood stream as a bolus and cause potassium intoxication. Better mixing is obtained by administering potassium directly into the container rather than into the injection port. Also, instilling the potassium before the container is inverted seems to promote mixing.

## Causes of hyperkalemia

- I. **Increased intake** (usually in patients with renal failure)
- II. **Redistribution out of cells**
  1. Metabolic acidosis
  2. Insulin deficiency
  3. Hyperosmolality (usually hyperglycaemia)
  4. Beta2 adrenergic antagonists
  5. Alpha-adrenergic antagonists
  6. Cell damage (lysis)
- III. **Decreased potassium secretion**
  1. Renal failure
  2. Primary hypoaldosteronism: adrenal insufficiency, adrenal enzyme deficiency
  3. Secondary hypoaldosteronism: hyporeninemia, drugs ACE inhibitors, NSAIDs)
  4. Resistance to aldosterone: pseudohypoaldosteronism, tubulointestinal disease, drugs (K-sparing diuretics)

## Symptoms of hyperkalemia

Physical examination	ECG changes
<ul style="list-style-type: none"><li>• Usually asymptomatic</li><li>• Muscular weakness</li><li>• Tremor</li><li>• Paresthesias</li></ul>	<ul style="list-style-type: none"><li>• Peaked T waves</li><li>• Prolonged PR interval</li><li>• Disappearance of the P waves</li><li>• Prolongation and decomposition of the QRS complex</li><li>• Ventricular fibrillation</li></ul>

### Laboratory tests:

- Blood: Plasma potassium concentration, plasma osmolality, BUN, plasma creatinine concentration  
(*Other specific for the underlying disease*)
- Urine: Urine potassium excretion, urine output, urine osmolality.

# Hyperkalemia

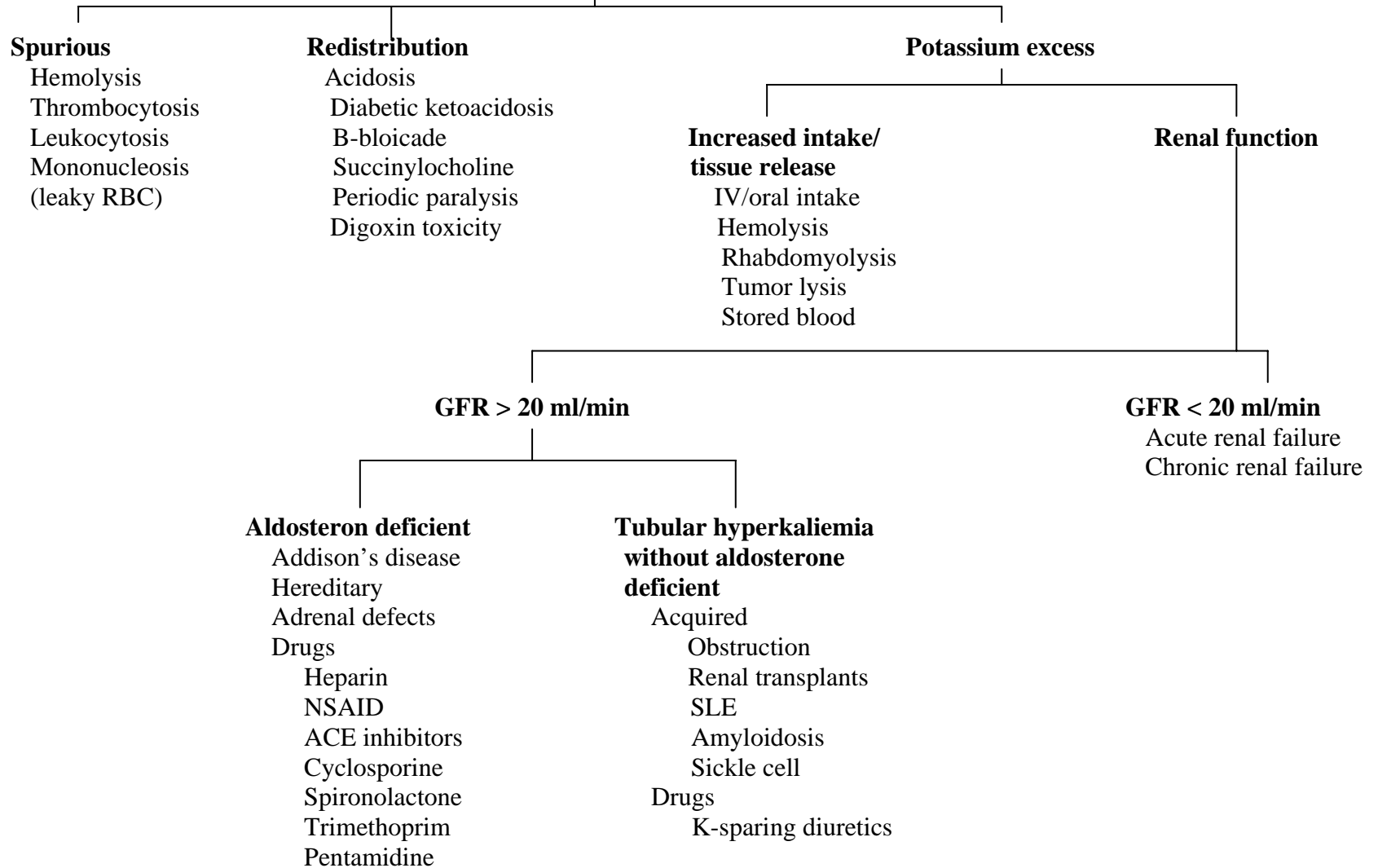

## References:

1. B.D. Rose: *Clinical physiology of acid-base and electrolyte disorders*. McGraw-Hill Health Professions Division 2001
2. Harrison's Principles of Internal Medicine. 14<sup>th</sup> ed. McGraw-Hill. 1998.
3. Henry J.B. *Clinical Diagnosis and Management by Laboratory Methods*. 19<sup>th</sup> ed. W.B. Saunders Company. Philadelphia 1996.
4. Ravel R. *Clinical Laboratory Medicine. Clinical Application of Laboratory Data*. 6<sup>th</sup> ed. Mosby-Year Book. 1995.





## Human chorionic gonadotropin (hCG)

- It is a number of glycoprotein hormone family synthesized and secreted by **trophoblast cells of the placenta**.
- a free  **$\beta$ -subunit of hCG** has been detected in the serum of **pregnant women** and
- in patients with: **gestational trophoblastic disease** (e.g. choriocarcinoma), **testicular carcinoma** (more than 60% of patients with nonseminomas and up to 30% with seminomas) and **rarely** in patients with **other malignancies** such as bladder cancer.

## Alpha-fetoprotein (AFP)

- AFP is the major fetal serum protein and is synthesized by the yolk sac and the fetal hepatocytes, and to a lesser extent by the fetal GI and kidney.
- AFP is also one of the major carcinoembryonic proteins.
- Elevated AFP in patients with primary hepatocellular carcinoma and germ-cell tumors of testicular, extragonadal and ovarian origin.
- In both hepatomas and germ-cell tumors, the AFP level correlates with tumor bulk and frequency of elevated AFP levels increases with disease stage.
- AFP is the most useful serum marker for the management and the diagnosis of hepatocellular carcinoma.

## CA 19-9

- **Increased** levels of **CA 19-9** is found in patients with a **wide range of GI malignancies** and also in a small number of **bladder tumors**.
- Serum **CA 19-9** concentrations are highly and frequently **elevated** in both **gastric and pancreatic carcinomas** and is useful for **monitoring** the success of **therapy** and for **detecting recurrence**
- **Monitoring** the patient **after gastric cancer surgery** with both: **CEA and CA 19-9** is the **gold standard**, now

## CA 125

- It is a carbohydrate antigen normally present during embryonic development of coelomic epithelium and is present in adult structures derived from it.
- **Increased** levels of **CA125** are found in **more than 80% on nonmucinous epithelial ovarian carcinomas at presentation** and **correlate with tumor bulk**. **CA125** is used for **monitoring** possible relapse and **elevated concentrations may precede clinical recurrence by months**.
- **CA 125** is also used clinically for a **follow-up on the uterine tumors and benign tumors including endometriosis**.

## Prostate-specific antigen (PSA)

- PSA is synthesized in the epithelial cells of the prostate gland.
- Usefulness: helpful in diagnosis and management (particularly after surgery) of prostate cancer.
- Lack of cancer specificity and not full cancer sensitivity are the drawbacks of PSA.
- The use of digital rectal examination (or transrectal USG) in combination with PSA as a screening tool for detecting clinically significant prostate cancer was previously recommended

### Methods to improve PSA clinical utility:

- **age-specific** reference ranges,
- **free and complexed PSA**.

### Methods for utilizing PSA if you have a diagnostic problem:

- *PSA velocity*,
- *PSA density*.

## CA 15-3

- It is a number of carbohydrate antigens useful in **the management of breast cancer patients**.
- Levels of **Ca 15-3 are raised in 20%** of women **with localized breast cancer** and up to **80% in metastatic disease**.
- It has a **specificity of 86 % and sensitivity of 30%** and has been a **useful tool in monitoring** the course of **the disease**.
- **Ca 15-3 can rise also in other malignancies**, e.g.: cancer of the **stomach, pancreas, lung and uterus**.

## Tissue polypeptide antigen (TPA) and tissue polypeptide-specific antigen (TPS)

- It is a mixture of **cytokeratin fragments**. Cytokeratins form the protein cytoskeleton of epithelial cells and increase in the circulation in the presence of rapid cell growth. **TPA** appears to be a **measure of cellular proliferation-reflects speed of mitosis**.
- Monoclonal mapping of **TPA** molecule has revealed many different epitopes: one of essential is **TPS**.
- In contrast to other tumor markers related rather to tumor mass, **TPA** and **TPS** are sensitive but nonspecific markers **for discriminating between progressive disease and disease in complete remission**.
- Many reports emphasize **the use of TPA, TPS in combination with other markers, especially CEA, for earlier detection and monitoring a variety of carcinomas**, including breast, colorectal, ovarian, bladder, pancreas and lung.

## Molecular definition of malignant tumor

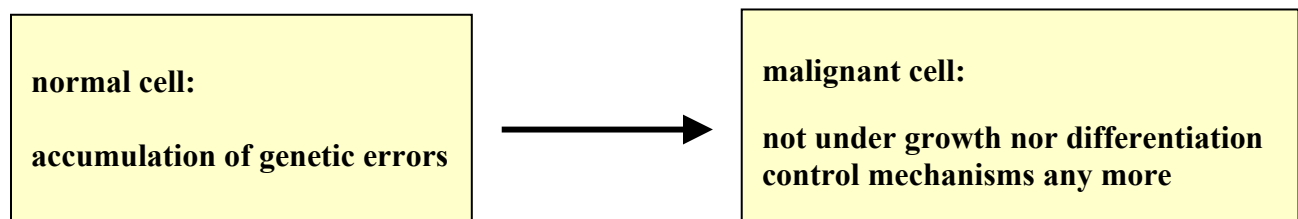

### **ONCOGENES and its protein products are growth inducing.**

**In normal cells** its precursors-**protooncogenes**:

- play important regulatory role of cell proliferation, differentiation and maturation.
- its protein products can act as growth factors, its receptors, signal transmission or transcriptional factors in nucleus

**Activation of protooncogenes** → **oncogenes** can be caused by **implanted viral gene** or **structural changes in cell genome** (point mutation, translocation, amplification of protooncogenes).

**Examples:** **ras** encodes proteins H-ras, K-ras, N-ras (pulmonary ca, ca of pancreas, GI tract ca, prostate ca, AML) → **loosing of contact inhibition**; **myc** (colorectal ca, breast ca) → **immortality**, **bcl-2** → **prevents apoptosis** p53 dependent and p53 independent.

## TUMOR SUPPRESSOR GENES and its protein products are growth-inhibiting.

In normal cells play role in:

- **growth regulation**
- **DNA repair** (when cells sustain DNA damage, cellular „hibernation”, manifested by an arrest at the G1 or G2 checkpoint permits repair to take place and prevents the accumulation of mutant sequences)
- apoptosis/cell survival (**promotion of apoptosis**-programmed cell death→to clear tissues of damaged cells with a high cancer potential)
- **chromosomal stability**
- **cell adhesion**
- **transcription**

**Examples:** **p53** (the encoding gene for p53 has been found to be **mutated in about half of almost all types of cancer**. It can be measured in ether tissue, fibroblast, white blood cell, or serum. The wild-type p53 protein in the blood circulation is not detectable due to its short half life, missense mutations increase the half life and quantity of the p53 protein. A mutant p53 renders cells less likely to undergo apoptosis after cellular stress, with chemotherapeutic agents and gamma irradiation); **BRCA1** and **BRCA2** →**susceptibility to breast and ovarian ca**; **rb** →**retinoblastoma**.

## EXAMPLES OF MOLECULAR TUMOR MARKERS/THERAPEUTIC TARGETS:

breast cancer	Estrogen receptors, HER-2
CML,	bcr/abl fusion gene (Philadelphia chromosome)
CML, GIST	tyrosine kinase
breast, lung, colon cancer	vascular endothelial growth factor
breast, ovarian cancer	BCRA 1, BCRA 2
epithelial cancers expressing CEA	antiCEA mAbs

## HER-2

- HER is a proto-oncogene encoding a transmembrane receptor (EGFR) with tyrosine kinase activity.
- HER-2 has been found to be important for regulating cell growth and differentiation.
- It has been demonstrated that protein overexpression inversely correlates with the estrogen receptor level and predicts resistance to antiestrogen therapy, even in estrogen receptor positive disease. Also it predicts worse answer to classical chth (better to taksons and antracyclins).
- Breast cancer showing HER-2 gene amplification and protein overexpression has a worse clinical prognosis.
- Also, high HER-2 expression is highly associated with androgen independence in prostate cancer and may identify patients more likely to have disease progression.
- MAbs (monoclonal antibodies) to HER-2 can inhibit the proliferation of tumor cells that overexpress this gene and mediate antibody-dependent cellular cytotoxicity. The drug is called Trastuzumab (Herceptin).

## Usefulness of tumor markers

### Monitoring treatment :

- is **one of the most useful applications** of TM,
- the serum level of tumor marker reflects well success of surgery or the efficacy of chemotherapy and radiotherapy,
- levels of tumor marker can be a guide for the selection of the most effective drug for each individual case (e.g. estrogen and progesterone receptors in breast cancer tissue, HER-2 in breast or prostate cancer)
- detecting elevated levels of marker after surgery may indicate incomplete removal of the tumor, the presence of metastases, or recurrence.

### Detection of recurrence:

- is **the second most useful application** of tumor markers,
- the appearance of most tumor markers has a „lead time” of several months prior to the stage at which many of the physical procedures could not detect tumor,
- the specificity of tumor markers is not a problem for this application.

### Prognosis:

- most tumor markers become increasingly elevated when tumor metastasized,
- the detection of tumor markers highly associated with malignancy and metastases usually suggests more aggressive treatment.

### Diagnosis:

The problems with both specificity and sensitivity associated with most tumor markers precludes their measurement for their use in the diagnosis of cancer.

- the frequency of detecting elevated levels of tumor markers in
- non-neoplastic diseases discourages their use in diagnosis,
- the overlap observed between the normal concentrations and the concentrations
- of tumor marker in patients with proven cancer.

**Screening:**

None of the tumor markers discovered have adequate specificity and sensitivity for screening.

**Exceptions:**

- in South Asia and China the screening for primary hepatoma is based on the measurement of serum AFP and abdominal US,
- the feasibility of screening ovarian cancer in women by measuring serum CA 125 is still in the process of investigation,
- BCRA 1 and BCRA 2 for susceptibility of breast and ovarian cancer.

**Recommendations of ordering tumor markers tests**

- ⇒ never rely on the single test ( it is difficult to differentiate between malignant diseases and either benign or non-neoplastic diseases based on the single test)
- ⇒ when ordering serial testing, be certain to order every test from the same laboratory using the same assay kit
- ⇒ be certain that the tumor marker selected for monitoring recurrence was elevated in the patient before surgery
- ⇒ consider the half-life time of the tumor marker when interpreting the test result
- ⇒ consider how the tumor marker is removed or metabolized from the blood circulation (elevated serum tumor markers are frequently detected in patients with a renal or a liver disease depending on whether the tumor marker is removed through glomerular filtration or metabolized by the liver)
- ⇒ consider ordering multiple tumor markers to improve both the sensitivity and specificity
- ⇒ be aware of the presence of ectopic tumor markers.

## **Breast cancer: an example of full spectrum of TM used in clinical practice:**

### **1. Markers of morphological differentiation:**

- H-P type and grading
- ER, Pg receptors in breast cancer tissue (prognostic and predictive factor: +/+ 80% positive answer of therapy , +/- or -/+ 60%, -/- 10%)
- DNA ploide

### **2. Markers of neo invasion:**

- metaloproteinases ( enzymes responsible for degradation of extracellular matrix; e.g. gelatynases, etc)
- cathepsyn D
- growth factors, oncogenes and its protein products (e.g. HER-2)

### **3. Markers of proliferation**

- accumulation of p53, etc.
- TPS, TPA ( sensitivity 95%)

### **4. Serum markers:**

- CEA ( never used alone, for estimation of bone metastases)
- CA 549 (sensitivity rises with advance of the disease)
- CA 15-3 (a STANDARD!, specificity 85-100%, also to follow up!)
- MCA
- Ca 125 ( indicator of pulmonary meta)

**Notice!!!! The best constellation of tests: TPA+TPS+CA 15-3**



## **Hemoccult II (guaiac-based) slide test for fecal occult blood**

In the presence of peroxidase or pseudoperoxidase ( red blood cells) in fecal specimen and with the addition of hydrogen peroxide in the test, the indicator (guaiac) is oxidized to a blue quinone compound.

Because the pseudoperoxidase activity of hemoglobin tends to be altered as it passes though the GI tract, bleeding from the upper GI is less likely to produce a positive result than is lower GI tract bleeding.

The American Cancer Society has made the following recommendations for using the Hemoccult II test:

1. Subjects should avoid ingesting red meat, fish and high peroxidase foods (horseradish, turnips, bananas, black grapes, pears, and plums)for three days before and during testing.
2. Use of vitamin C and other antioxidants, iron tablets and NSAIDs should be avoided.
3. Two samples of each of three consecutive stools should be tested
4. The delay between preparation and lab testing should not exceed six days.
5. Slides should not be dehydrated
6. A single positive smear should be considered a positive test result, even in the absence of dietary restriction.

The sensitivity of FOBT for detecting asymptomatic colorectal ca and adenomas is difficult to estimate. Between 50% and 90 % of tests in patients with known colorectal ca have been reported to yield positive results with Hemoccult II. The positive predictive value of the test in two controlled trials was reported to be 10 % for carcinoma and 30 % for adenomas for the initial screening test.

**Immunochemical stool tests for human hemoglobin** have a 97 % sensitivity for colorectal ca and 76 % sensitivity for adenomas of larger than 1 cm. Estimated specificity was 98%. The major advantage of the immunochemical tests is the absence of a need for dietary modification.

## References

1. Perry M.C. Annual Meeting May 15-18, 1999, Atlanta, GA. 35<sup>th</sup> ed. American Society of Clinical Oncology, Educational Book, Aleksandria 1999
2. DeVita V.T., Hellman S., Rosenberg S.A. Cancer Principles & Practice of Oncology. 3<sup>rd</sup> ed. J.B. Lippincott Company, Philadelphia 1989.
3. Cecil Essentials of Medicine. 3<sup>rd</sup>.ed. W.B. Saunders Company. Philadelphia 1993.
4. Kasper, Braunwald, Fauci, Hauser, Longo, James (ed): Harrison's principles of internal medicine. (16<sup>th</sup> ed.). McGraw-Hill 2005
5. Henry B J (ed.): Clinical Diagnosis and Management by Laboratory Methods. (20<sup>th</sup> ed.). W.B. Saunders Company 2001

## Plasma proteins and laboratory diagnosis of inflammation and infectious diseases

*Miłostawa Zowczak-Drabarczyk MD*

### Causes of hypoproteinemia:

<p>With hypoalbuminemia:</p> <p>I. <u>Impairment of liver protein synthesis:</u></p> <ul style="list-style-type: none"> <li>– malnutrition, malabsorption</li> <li>– hepatocellular disease, primary or metastatic tumor to the liver</li> </ul>	<p>III. <u>Changes in the extracellular space volume→changes in protein distribution:</u> (pseudohypoproteinemia!)</p> <ul style="list-style-type: none"> <li>– overhydration</li> <li>– prolonged bed-rest</li> </ul>
<p>II. <u>Increased protein loss:</u></p> <ul style="list-style-type: none"> <li>– through kidney→nephrotic syndrome</li> <li>– through gastrointestinal tract→protein-losing enteropathies (e.g. GI malignancies, Crohn’s disease, ulcerative colitis, celiac sprue)</li> <li>– through skin→extensive skin damage (e.g. burns, dermatosis)</li> <li>– with blood→haemorrhage</li> <li>– with exudates (e.g. peritoneal, pleural)</li> <li>– in catabolic states (e.g. sepsis, end-stage neoplastic disease, extensive injury)</li> </ul>	<p>IV. <u>Dilution of the sample with the infusion fluid without protein</u> (pseudohypoproteinemia!)</p> <p>Without hypoalbuminemia</p> <p>V. <u>Severe immunoglobulin deficiency</u> (congenital and acquired)</p>

### Causes of hyperproteinemia:

<p>I. <u>Hypergammaglobulinemia:</u></p> <p>1. Monoclonal gammopathies:</p> <ul style="list-style-type: none"> <li>– multiple myeloma</li> <li>– Waldenström’s macroglobulinemia</li> <li>– heavy-chain diseases</li> <li>– monoclonal gammopathies of undetermined significance</li> <li>– other diseases of lymphatic system</li> </ul>	<p>2. Polyclonal gammopathies, e.g.:</p> <ul style="list-style-type: none"> <li>– chronic inflammation</li> <li>– autoimmune diseases</li> <li>– chronic liver disease</li> </ul>
<p>II. <u>Dehydration</u> (pseudohyperproteinemia!)</p>	<p>II. <u>Prolonged use of tourniquet</u> (pseudohyperproteinemia!)</p>

## Serum albumin

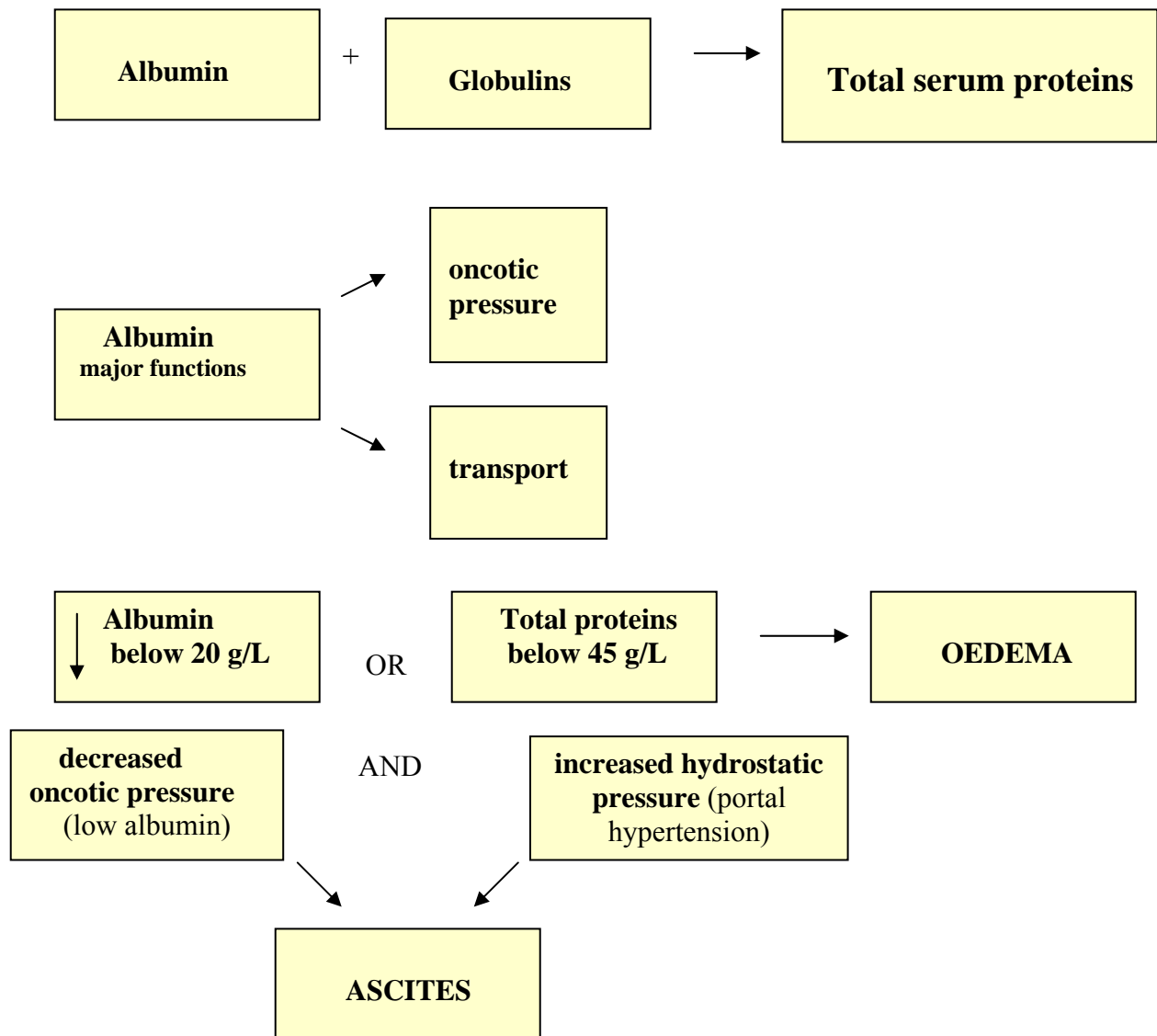

## Normal electrophoretic pattern, reference values

Albumin	35-55 g/L	50 – 60%
Globulin	20-35 g/L	40-50%
$\alpha_1$	2-4 g/L	2,5-5%
$\alpha_2$	5-9 g/L	7-13%
$\beta$	6-11 g/L	8-14%
$\gamma$	7-17 g/L	12-22%

*Diagrams: serum protein electrophoresis pattern 1. and 2.*

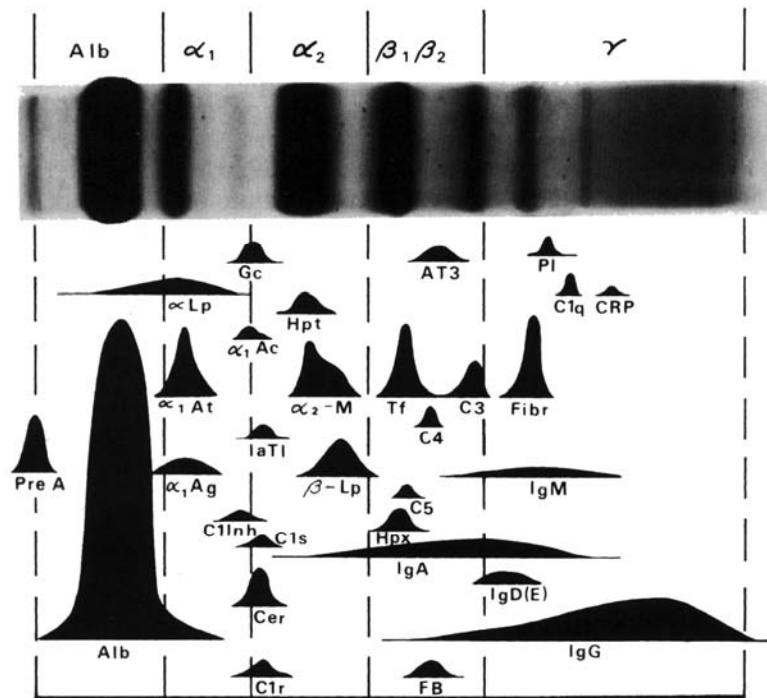

$\alpha_1$ Ac =  $\alpha_1$ -Antichymotrypsin  
 $\alpha_1$ Ag =  $\alpha_1$ -Acid glycoprotein  
 $\alpha_1$ At =  $\alpha_1$ -Antitrypsin  
 $\alpha_2$ -M =  $\alpha_2$ -Macroglobulin  
 $\alpha$ -LP =  $\alpha$ -Lipoprotein  
 Alb = Albumin  
 AT3 = Antithrombin III  
 $\beta$ -Lp =  $\beta$ -Lipoprotein

Complement components:  
 C1q, C1r, C1s, C3, C4, C5 = As designated  
 C1Inh = C1 esterase inhibitor  
 Cer = Ceruloplasmin

CRP = C-reactive protein  
 Gc = Gc-globulin (vitamin D-binding protein)  
 FB = Factor B  
 Fibr = Fibrinogen  
 Hpt = Haptoglobin  
 Hpx = Hemopexin  
 Immunoglobulins:  
 IgA, IgD, IgE, IgG, IgM = As designated  
 IaTI = Inter- $\alpha$ -trypsin inhibitor  
 Pl = Plasminogen  
 Pre A = Prealbumin  
 Tf = Transferrin

**Serum protein electrophoresis pattern** (after: Henry J.B.: *Clinical Diagnosis and Management by Laboratory Methods*, 20<sup>th</sup> ed. W.B. Saunders Company, Philadelphia 2001., modified)

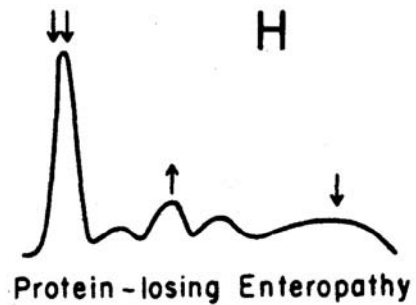
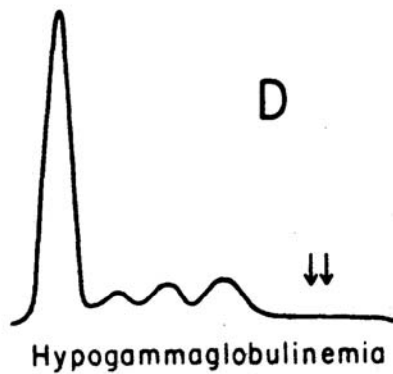
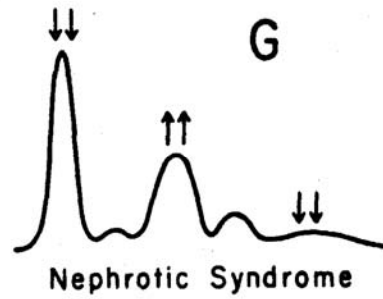
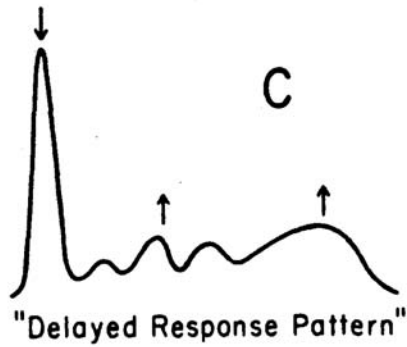
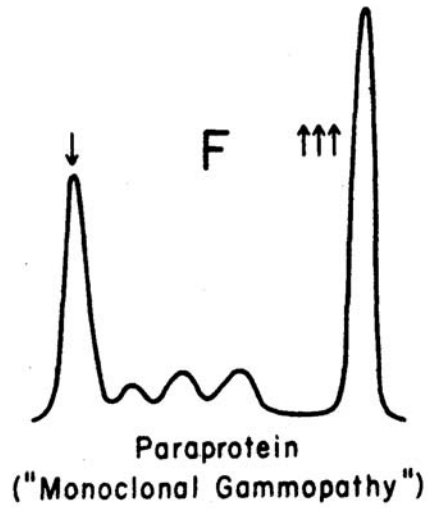
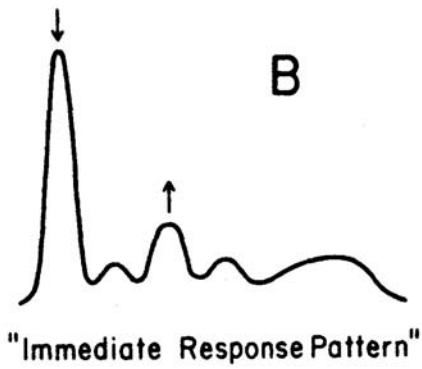
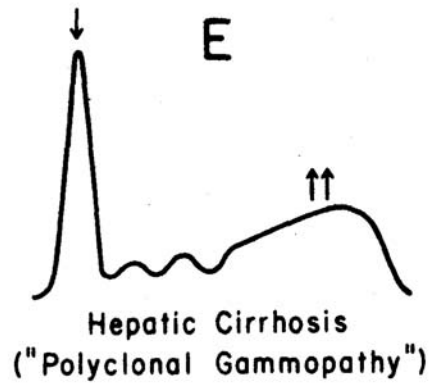
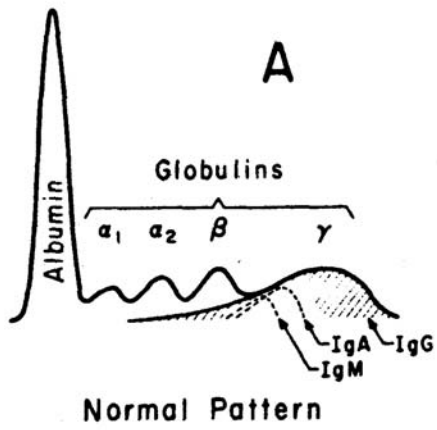

**Typical serum protein electrophoresis patterns** (after: Henry J.B.: *Clinical Diagnosis and Management by Laboratory Methods*. 20<sup>th</sup> ed. W.B. Saunders Company. Philadelphia 2001., modified)

## Protein concentrations in urine, reference values

Total protein	< 150 mg/ 24 h collection
Albumin	<30mg/ g of creatinine
Light chains	< 10 mg/ 24 h collection

Microalbuminuria: 30-300 mg of albumin/ g of creatinine in 2 out of 3 consecutive tests

Macroalbuminuria: > 300 mg of albumin/ g of creatinine in 2 out of 3 consecutive tests

## Erythrocyte sedimentation rate (ESR), reference values

	Men	Women
Newborns	0-5 mm/1 h	0-5 mm/1 h
Infants	17 mm/1 h	17 mm/1 h
Below age 50 years	15 mm/1 h	20 mm/ 1 h
Above age 50 years	20 mm/1 h	30 mm/1 h
Above age 85 years	30 mm/1 h	42 mm/1 h

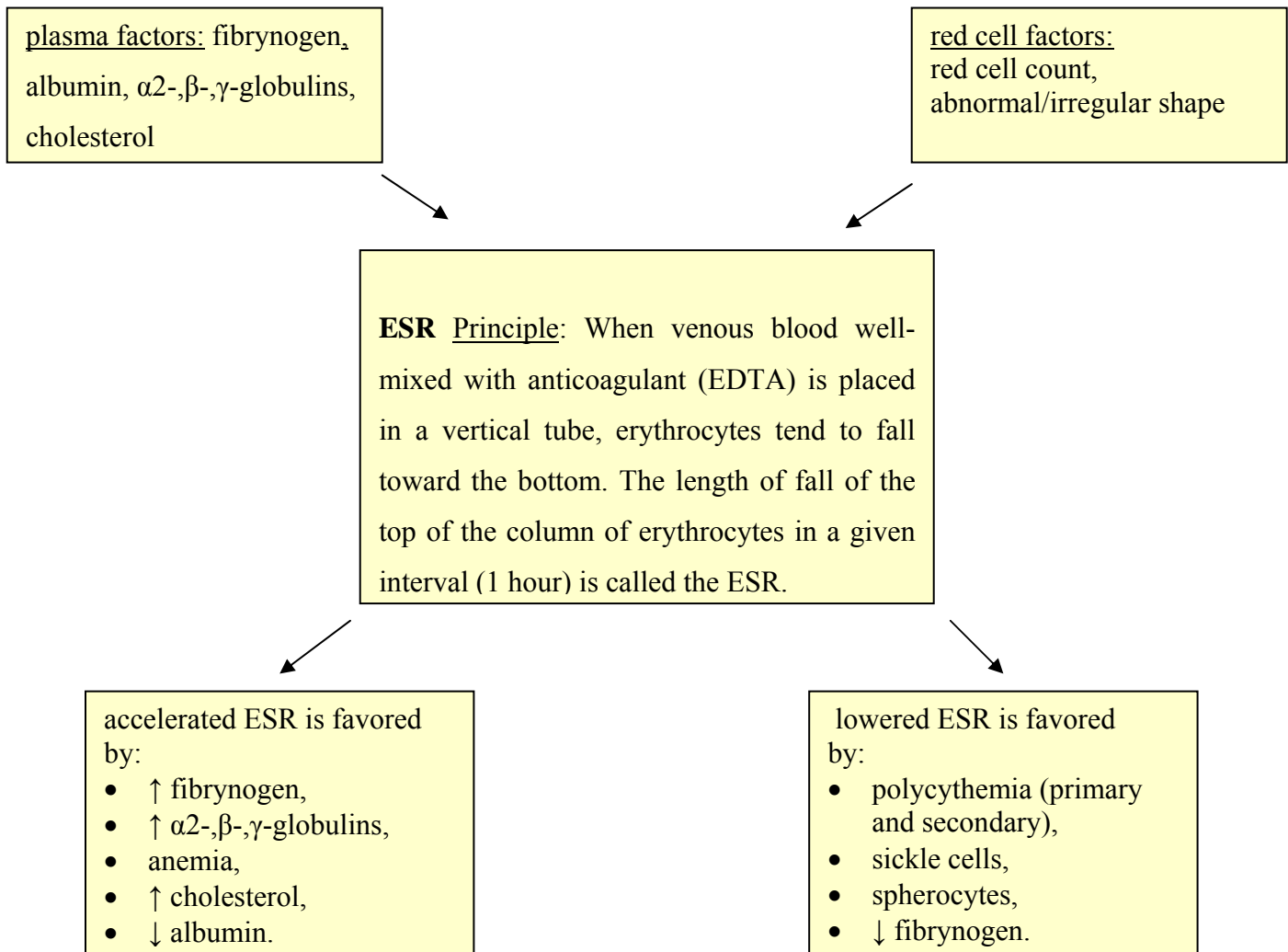

Interpretation: —→ *Physiologically*, the ESR *increases* moderately during *menstruation*, in *pregnancy* (beginning at the tenth to twelfth weeks, and return to normal about one month postpartum), and with aging (*above 50 years*).

—→ The ESR tends to be markedly elevated in monoclonal blood protein disorders, in severe polyclonal hyperglobulinemias due to inflammatory disease or cancer and in hyperfibrinogenemia.

—→ **Moderate elevations of ESR** are common in **active inflammatory diseases** such as rheumatoid arthritis, **infections (especially bacterial)**, **collagen disease**, and **malignancy**. ESR has little diagnostic value in these disorders, but it can be useful in monitoring disease activity.

—→ *ESR normal does not exclude any pathology.*

## C- Reactive Protein (CRP)

CRP is generally useful acute phase reactant for diagnosing and monitoring inflammatory response. CRP is the fastest rising acute phase protein and one that returns to normal quickly following successful therapies: it begins to rise 4-6 hours after onset of inflammation and its T<sub>1/2</sub> is only 5-7 hours.

Classical CRP assay methods: CRP is frequently applied to the detection and preliminary classification of occult infection because bacterial infection can stimulate much higher CRP levels than viral ones. It is also widely used for assessing disease activity in autoimmune disorders (e.g. in very active phase of rheumatoid arthritis it can rise 20-fold). The normal serum concentration of CRP is up to 10 mg/L (in some laboratories up to 5 mg/L).

Ultrasensitive CRP assay methods: CRP is an independent prognostic factor of acute cardiac incident (ACI) in primary and secondary prevention. Low risk of ACI when CRP < 1mg/L, increased risk of ACI when CRP 1-3 mg/L, high risk of ACI when CRP >3 mg/L.



## Production of acute phase proteins

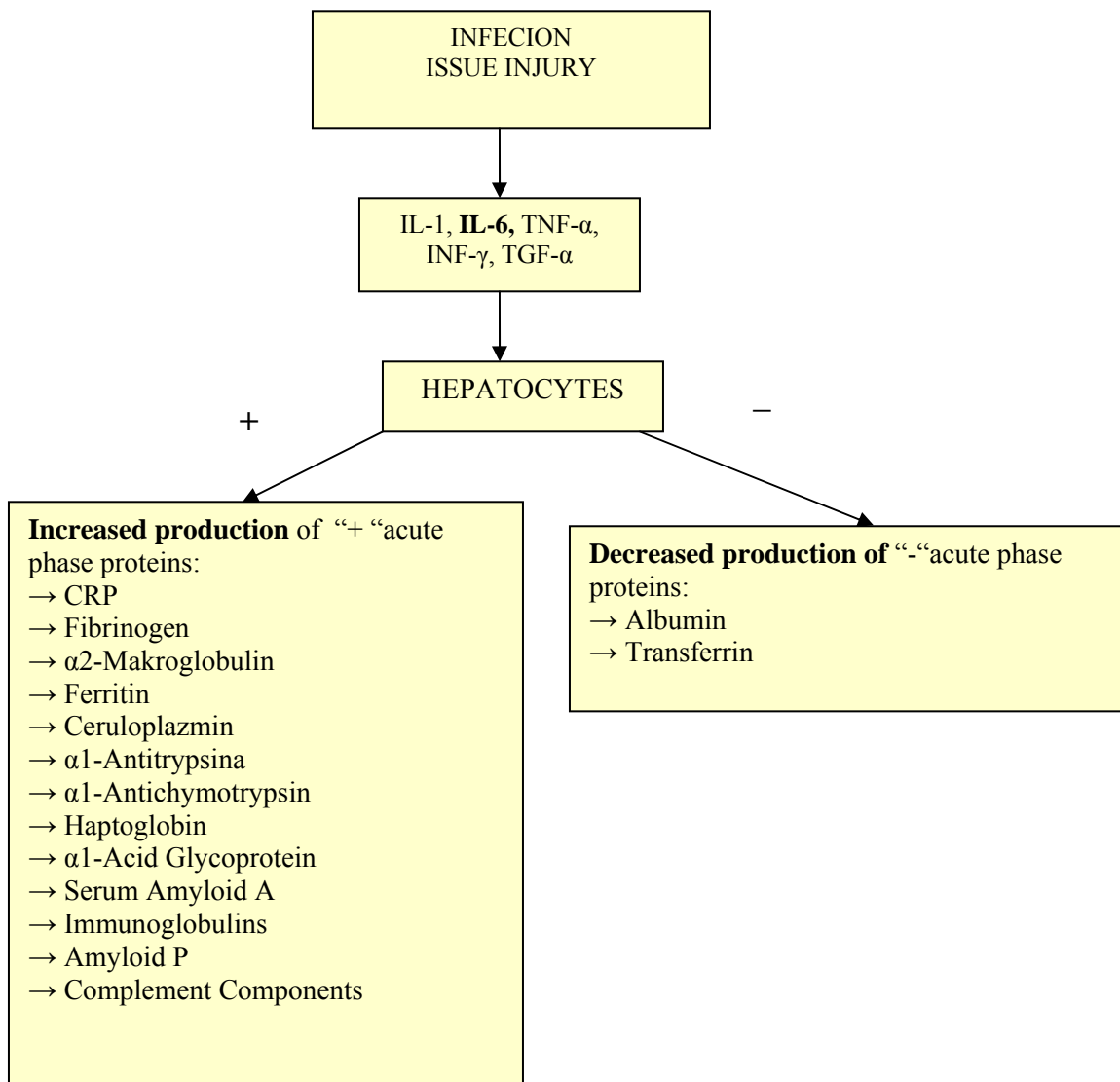

### **PROCALCITONIN:**

- **better marker than CRP for discrimination of SIRS from sepsis and for the monitoring of patients with sepsis**
- **better correlates with outcomes of antibiotic therapy than CRP**

# Urinalysis and other laboratory procedures in the diagnosis of the urinary tract disorders

Hanna Kara-Perz MD, Dorota Formanowicz MD

## URINE EXAMINATION

Quantity of urine excretion:

**Normal urine:** 1000-1500 ml of urine per day

**Oliguria:** <500 ml of urine per day (is present when the urine flow rate is less than the minimum required to allow excretion of daily solute load)

**Anuria:** <100 ml of urine per day or the complete absence of urine flow

- in general, the causes of anuria and oliguria are the same as those of acute renal failure

**Polyuria:** is a term, indicating passage of large volume of urine, but implying nothing about the appropriateness (or otherwise) or cause of the high urine flow rate

- causes: excessive water intake (psychogenic polydipsia), osmotic diuresis (diabetes mellitus (glucose), chronic kidney disease (urea), abnormal tubular water handling)

## Physical evaluation

Urinary pH - mean 6,2 (4,6-8,0)

Alkaline urine suggests:	Acid urine suggests:
<ul style="list-style-type: none"><li>• vegetarian diet</li><li>• alkali ingestion (sodium bicarbonate, potassium citrate)</li><li>• infection with urea-splitting organisms</li><li>• metabolic alkalosis</li><li>• respiratory alkalosis (acute)</li><li>• renal tubular acidosis (type I)</li><li>• water diuresis</li></ul>	<ul style="list-style-type: none"><li>• high protein diet</li><li>• acid ingestion (ascorbic acid, ammonium chloride)</li><li>• potassium depletion</li><li>• metabolic acidosis</li><li>• respiratory alkalosis (acute)</li><li>• hyperaldosteronism</li><li>• water deprivation</li><li>• intoxication of methyl alcohol</li></ul>

## Colour

**Normal urine** - pale, straw-yellow colour (due to the presence of the pigment urochrome), it may also appear deep amber or almost colourless

**Discoloration** (as a result of pathology or secondary to the presence of drug or food)

- **orange urine:** bile pigments, nitrofurantoin, phenothiazines, rhubarb, carrot, senna
- **yellow urine:** bile pigments, rhubarb, carrot, nitrofurantoin, phenacetin
- **green:** biliwerdin, methylene blue, nitrofurans, vitamin B complex
- **blue-green, blue urine:** nitrofurans, methylene blue
- **red urine:** RBC, myoglobin, hemoglobin, porphyrins, bromsulphophthalein, phenytoin, senna, beetroots
- **brown or black urine:** biliary pigments, hematin, myoglobin, iron salts, nitrofurans, sulphadiazine

## Odour

- **ammonia odour:** break-down of urea in the urine
- **pungent aroma:** UTI, high ammonia conc., failure to deliver the specimen to the laboratory in the fresh state
- **other very characteristic odours:** maple syrup urine disease, phenylketonuria, isovaleric acidemia

## Turbidity (phosphates, leukocyturia, bacteriuria, chyluria)

## Specific gravity

- The **normal** spectrum of urinary specific gravity results for random specimens ranges from **1.003 to 1.040**
- The specific gravity of a **first-morning specimen** should be greater than **1.015**
- **Very high values**- presence of glucose or protein
- **Dilute urine** – high fluid intake, tubular disorders, diuretics administration, early glomerular disease
- **Very dilute urine (between 1.001 and 1.005)**- extremely high fluid intake, diuretics administration, diabetes insipidus

## Chemical evaluation

### Protein

**Normal urine:**  $\leq 150$  mg per day, with exception of *orthostatic proteinuria*

The protein excretion rate is generally increased in the up-right posture, and, on occasion, this may lead to abnormally high protein measurements in timed collections or spot measurements in normal ambulant subjects. This is termed *orthostatic proteinuria* and the diagnostic difficulty may be resolved by demonstrating that an-early-morning urine specimen is normal while a specimen taken later in the day with the subject ambulant contains excess protein

### **Proteinuria: >150 mg per day**

DEGREE OF PROTEINURIA	DIAGNOSTIC IMPLICATIONS
<b>MILD (up to 500 mg/day)</b>	<ul style="list-style-type: none"><li>• fever</li><li>• benign hypertensive nephrosclerosis</li><li>• renal tumour</li><li>• obstructive nephropathy</li><li>• chronic pyelonephritis</li><li>• early diabetic nephropathy</li><li>• orthostatic proteinuria</li></ul>
<b>MODERATE (up to 3 g/day)</b>	<ul style="list-style-type: none"><li>• urinary tract infection (UTI)</li><li>• chronic pyelonephritis</li><li>• acute tubular necrosis</li><li>• acute/chronic glomerulonephritis</li><li>• obstructive nephropathy</li><li>• accelerated phase hypertension</li><li>• orthostatic proteinuria</li></ul>
<b>HEAVY (more than 3 g/day)</b>	<ul style="list-style-type: none"><li>• pre-eclampsia</li><li>• myeloma</li><li>• acute/chronic glomerulonephritis</li><li>• diabetic nephropathy</li><li>• all causes of nephrotic syndrome</li></ul>

## Categories of proteinuria:

### 1. Prerenal proteinuria

- the first type - abnormal low molecular weight protein easily passes through the glomerulus into the urine
- the second type - change in hydrostatic pressure in the kidney glomerulus

### 2. Glomerular proteinuria

- in the **earliest stages** of glomerular damage proteinuria is *selective* and the urinary proteins are the lowest molecular weight proteins found in the bloodstream
- in the **advanced stages**, if glomerular damage progresses, all of the proteins found in the blood may appear in the urine (*non-selective proteinuria*)

### 3. Tubular proteinuria

- generally mild, low molecular weight
- usually secondary to: tubular damage, heavy metal intoxication, vitamin D intoxication, galactosemia, pyelonephritis, acute tubular necrosis, polycystic kidney disease

### 4. Mixed proteinuria

- $\beta_2$  microglobulin is mainly excreted (glomerular and tubular damage)

### 5. Lower urinary tract proteinuria

- exudation of protein through the mucosal layer of the lower urinary tract
- secondary to UTI

### 6. Asymptomatic proteinuria - orthostatic

## Albumin

- **normal urine:** urinary albumin excretion less than 30 mg/24h, urine albumin concentration less than 20 mg/l
- **microalbuminuria** – urinary albumin excretion rate from or **30-300 mg/24h** (urine albumin concentration ranges from **20 to 200 mg/l**) – predicts the later development of clinical diabetic nephropathy
- **macroalbuminuria** - urinary albumin excretion rate **>300 mg/24h** (urine albumin concentration **> 200 mg/l**)

## Glucose

- glucose is filtered through the glomerulus
- body reclaims this filtered glucose in order to prevent the loss of carbohydrate energy ( active transport reabsorptive mechanism)
- when the plasma glucose conc. exceeds 10 mmol/l the reabsorptive capacity of the tubules is exceeded

## Ketones

Increased fat metabolism leading to ketoacidosis occurs in:

- **starvation**
- **insulin-deprivation**

## Hemoglobinuria

Causes:

- **intravascular hemolysis:** when the capacity of haptoglobin or hemopexin to bind and remove haemoglobin is exceeded, the free haemoglobin passes through the glomerulus into the urine
- **glomerular disease:** hemoglobinuria may be associated with the presence of red cells and red-cell casts in the urine
- **bleeding from the lower urinary tract:** it may be accompanied by red cells, but never red-cell casts

## Myoglobinuria

### Causes:

- crush injuries
- heavy exercise
- grand mal seizures
- coma
- myopathies

## Bilirubinuria

- appearance of conjugated bilirubin in the urine is strong evidence for obstruction lesion in the liver or biliary system

<b>prehepatic jaundice</b> (↑ unconjugated bilirubin)	absence
<b>hepatic jaundice</b> (↑ unconjugated and conjugated bilirubin)	presence
<b>posthepatic jaundice</b> (↑ conjugated bilirubin)	presence

## Urobilinuria

- increased urobilinogen can be found in the urine of those suffering from hepatocellular liver disease or hemolytic process

<b>prehepatic jaundice</b>	↑
<b>hepatic jaundice</b>	↑/↓
<b>posthepatic jaundice</b>	↓

## Leukocyte esterase

- presence of this esterase → presence of white cells in the urine

## Nitrite

### For the test to be positive:

- patients must have nitrate in the urine (production associated with the consumption of vegetables)
- only certain bacteria have the ability to produce nitrate-nitrite conversion
- **presence of nitrite** → presence of bacteria in the urine
- **negative test** → does not exclude the presence of UTI

## Microscopic examination: *Formed elements of the urine*

1. red blood cells
2. white blood cells
3. epithelial cells
4. microorganisms
5. crystals
6. casts

## 1. Hematuria - more than 5 RBC/1 $\mu$ l of urine

- **microhematuria (erythrocyturia)**- >5 RBC/1 $\mu$ l of urine or >3000 RBC/1ml of urine, these amounts of RBC are insufficient to cause visible discoloration of urine
- **macrohematuria** - more RBC than in microhematuria, with visible discoloration of urine

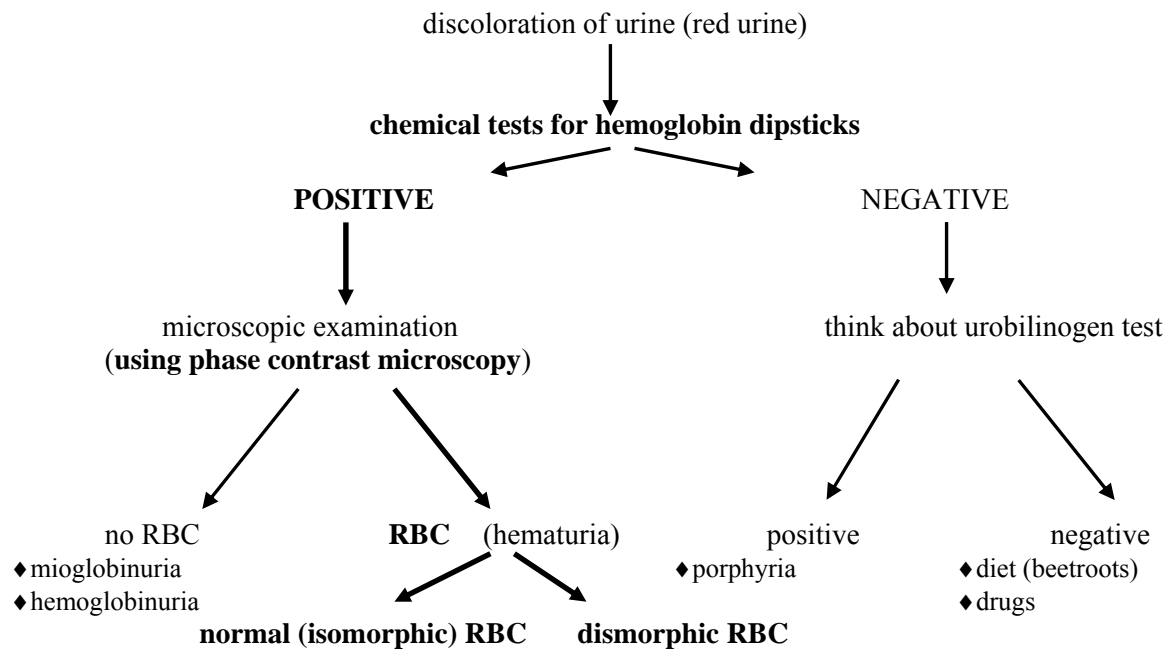

A positive test for hemoglobin should always be followed by microscopic examination for RBC (using phase contrast microscopy)

This will distinguish hematuria from hemoglobinuria and also may indicate whether RBC are derived from:

- the renal parenchyma - **dismorphic RBC** (are usually indicators of glomerular bleeding)
- the collecting systems, ureters, bladder – **normal (isomorphic) RBC**

**The causes of hematuria include:**

- **lower urinary tract lesions:** tumours, trauma, **calculi**, infection, congenital malformations, prostatic disease, stricture
- **upper urinary tract lesions:** tumours, trauma, calculi, infection, congenital malformations, renal arterial or venous disease, certain interstitial diseases, **glomerulonephritis**
- bleeding disorders associated with haematological disease or due to anticoagulant drugs disease adjacent to and impinging on the urinary tract

## 2. Leukocyturia more than 10 WBC/1 $\mu$ l of urine

- ◆ usually present in UTI
- ◆ **pyuria** – cloudiness of urine caused by the large amounts of WBC

## 3. Epithelial cells

Three major types of epithelial cells in the urine

- squamous
- transitional
- renal tubular cells

presence of moderate numbers of epithelial cells → no medical significance

presence of large numbers of epithelial cells → poor specimen collection

#### 4. Microorganisms

- although **bladder urine should be sterile, voided urine is not**, and interpretation of bacteriological studies of urine must take account of this
- contamination is minimized (though not eliminated) by use of the midstream urine (MSU), in which the initial part of the voided stream is discarded and the mid- portion of the stream collected in a sterile container
- the likelihood of significant infection is high if:
  - a pure growth of single organism is obtained (multiple organisms often indicate contamination)
  - the number of bacteria **exceeds  $10^5$ /ml**
  - leucocytes are present in the spun deposit of fresh urine

#### 5. Crystals

They form as a result of precipitation of inorganic salt contained in the urine

- cystine crystals – hereditary cystinosis
- leucine and tyrosine crystals
  - serious hepatic damage
  - hereditary metabolic disorder
- drug crystals (sulfa crystals, ampicillin crystals)
- uric acid crystals – acidic urine
- phosphates and calcium carbonate crystals – alkaline urine

#### 6. Casts (*collection of protein and cellular debris*)

- urinary casts consists of Tamm-Horsfall protein derived from the tubular epithelium
- formed in the distal nephron
- Tamm-Horsfall protein is alkali-soluble, so **there is no casts in alkaline urine**

#### Types of casts

- **hyaline** casts
  - theirs origin is tubular secretion of Tamm-Horsfall protein
  - presence may be nonspecific or may be due to glomerulonephritis, pyelonephritis, chronic renal disease, congestive heart failure, stress, exercise
- **red blood cells** casts
  - any conditions that damage the glomerulus, tubules or renal capillaries
- **white blood cells** casts
  - are rarely true cast
  - UTI
- **epithelial** casts
  - acute inflammatory process (glomerulonephritis, pyelonephritis)
- **granular** casts
  - chronic disorder, rarely seen in acute inflammation
  - may represent evolution of epithelial casts in which the cells themselves have degenerated
- **waxy** casts
  - severe chronic renal disease
  - advanced stage of hyaline casts
- **fatty** casts
  - severe renal disease, nephrotic syndrome
  - breakdown product of epithelial casts that contain fat bodies
- **broad** casts
  - ”renal failure casts”
  - all types of casts may be present in broad form
- **pseudo** casts
  - epithelial cells, WBC, RBC, bacteria may coalesce together, giving the appearance of a cast

## Blood examination

### UREA - 15 – 40 mg/dl

- major nitrogen-containing metabolite from the degradation of protein
- the **concentration** of urea in blood-stream depends on several factors:
  - **urea production** (**protein intake**, protein and blood in gastrointestinal tract, catabolic states, liver function)
  - **volume of body water** (in which urea is distributed)
  - **rate of urea elimination**

Ethiology of elevated urea level can be categorized as:

- **prerenal** (increased production of urea or decreased renal perfusion)
- **renal** (loss of functioning nephrons)
- **postrenal** (obstruction of the urinary tract)

**Blood urea nitrogen (BUN) = uric acid [mg/dl] × 0.46**

<b>BUN/creatinine serum concentration ratio</b>	<b>15:1 [mg: mg]</b> reference range
	<b>&gt;20:1</b> in acute renal failure (prerenal) and in partial obstruction of urinary tract
	<b>&lt;5-10:1</b> in liver diseases, malnutrition, rhabdomyolysis

**If GFR is below 25% of normal values → the serum concentration of urea exceeds its upper bound of normal values**

### CREATININE - 0,7 – 1,2 mg/dl

#### **Creatine:**

- synthesis in the liver
- muscle- total body stores of creatine
- degraded to creatinine

#### **Creatinine**

- excretion from the body by glomerulofiltration and secretion (slight) through the tubule
- The **concentration** of creatinine in blood-stream depends on several factors:
  - **creatinine production** (**muscle diseases**, high-meat diet, anabolic steroid use, severe exercise)
  - **volume of body water** (in which creatinine is distributed)
  - **rate of creatinine elimination**

Ethiology of elevated creatinine level can be categorized as:

- **prerenal** (increased production of creatinine or decreased renal perfusion)
- **renal** (loss of functioning nephrons)
- **postrenal** (obstruction of the urinary tract)

**If GFR is below 50% of normal values → the serum concentration of creatinine exceeds its upper bound of normal values**

### URIC ACID - 4,0-8,5 mg/dl (adult male) - 2,7-7,3 mg/dl (adult female)

- major end product of purine metabolism
- hyperuricemia:
  - increased production of uric acid (increased de novo synthesis- gout, rapid proliferation of cells, increased catabolism of purines)
  - decreased renal excretion of uric acid (renal failure, diuretics, aspirin <2 g/day, metabolic acidosis, toxemia, pregnancy)



## Renal function test

### GFR

- the most useful index of overall renal function
- amount of plasma ultrafiltered across the glomeruli per unit time (expressed in milliliters per minute)
- calculation of GFR requires a test substance that is freely filtrated at the glomerulus, but neither reabsorbed nor secreted by the tubules
- measured indirectly by estimating the clearance from urine of a plasma-borne substance (creatinine)

$$C=U \times V/P$$

C- clearance of creatinine

U- urine concentration of the creatinine (mg/dl)

V- urine flow rate (ml/min)

P- plasma concentration of the creatinine (mg/dl)

- the evaluated clearance of creatinine is usually 10% higher than actual GFR

#### Normal values:

- men 100-150 ml/min
- women 85-125 ml/min
- first week of life 30 ml/min/1,73 m<sup>2</sup>
- up to age 9 months mature levels

GFR declines slowly after age 40 (1ml/minute per year)

↑GFR: during pregnancy, high protein diet, hyperglycemia

↓GFR: limit of fluids intake, excessive loss of fluids (skin, lungs, kidneys, gastrointestinal tract), after using non-steroids anti-inflammatory drugs

**If calculated clearance of creatinine amount to  $\geq 10$  ml/min → this method for GFR estimation should be avoided, because of measurement error, which may be equal to 100%**

#### Relationship between creatinine clearance and plasma creatinine concentration:

##### Renal blood flow (RBF) and renal plasma flow (RPF)

not commonly measured in clinical medicine

RBF is high: about **25% of the resting cardiac** output, or 1300 ml/min, this corresponds to a RPF of 700 ml/min, of which **25% is ultrafiltered at the glomeruli**, giving GFR

### Fractional excretion of sodium (FE<sub>Na</sub>)

$$FE_{Na} = U_{Na} \times P_{Cr} / U_{Cr} \times P_{Na}$$

U<sub>Na</sub>- urine sodium concentration

P<sub>Cr</sub>- plasma creatinine concentration

U<sub>Cr</sub>- urine creatinine concentration

P<sub>Na</sub>- plasma sodium concentration

(as a percentage of filtered sodium can be determined from single blood and urine samples)

FE<sub>Na</sub> >1%

- acute tubular necrosis

FE<sub>Na</sub> <1%

- prerenal azotemia

# DISEASES

## SYMPTOMS AND SIGNS OF RENAL AND URINARY TRACT DISEASE

<b>renal pain</b>	<b>hematuria</b>	macroscopic microscopic
<b>anuria/oliguria</b>	<b>proteinuria</b>	asymptomatic symptomatic (nephritic syndrome)
<b>polyuria frequency</b>	<b>hypertension oedema</b>	peripheral pulmonary
<b>dysuria incontinence</b>	<b>uraemia</b>	

### 1. Urinary tract infections (UTI)

a working definition of UTI is the presence, in an appropriately collected mid-stream specimen of urine, of **more than  $10^5$  colony** forming units per ml of urine → this is merely an arbitrary limit above which significant infection is likely and below which infection is less likely

**SIGNIFICANT BACTERIURIA means  $\geq 10^{4(5)}$ / 1ml of midstream, clean-catch urine sample**

•**Enterobacteriaceae**

- bacterial counts  $< 10^4$ /1ml – usually contamination
- bacterial counts  $\geq 10^5$ /1ml in asymptomatic female-two specimens should be obtained to confirm the diagnosis

•**Gram-positive, fungi, bacteria with fastidious growth requirements**

- bacterial counts  $\geq 10^4$ /1ml may indicate UTI

#### Microscopic examination (nonspecific changes):

- **pyuria** (many patients with symptomatic UTI have pyuria)
  - **sterile pyuria** is defined as white cells in the urine in the absence of significant bacterial growth

#### Causes of sterile pyuria

- recently treated urinary infection
- tuberculosis
- acute interstitial nephritis
- chronic interstitial nephritis (including analgesic nephropathy)
- chronic pyelonephritis

- **white cells cast** (especially in pyelonephritis)
- **mild proteinuria**
- **hematuria** (hemorrhagic cystitis or other disorders such as calculi, glomerulonephritis, renal tuberculosis)

#### Predisposing factors to development of UTI:

1. **Female sex**
2. Failure of complete bladder emptying (e.g. prostatic hypertrophy, neurological disease)
3. Anatomical disorders of bladder (e.g. bladder diverticulum)
4. Vesicoureteric reflux (reflux of urine into ureters or kidney during micturition)
5. Pregnancy (the ureters and renal pelvis dilate during normal pregnancy)
6. Diabetes mellitus (only in patients with long standing disease)
7. Tumours (! **UTI may be the first sign of an underlying bladder tumour**)
8. Stones (the presence anywhere in the urinary tract makes infection more likely)

UTI include

- **urethral syndrome** (the combination of dysuria, frequency, urgency and strangury)
- **the clinical entities of cystitis** (symptoms are those of the urethral symptoms and are accompanied by pyuria and significant bacteriuria; the urine is usually cloudy, and may be foul-smelling) → the infection may ascend leading to acute pyelonephritis
- **acute pyelonephritis** (usually results from ascending infection, diabetics, and subjects with obstruction of the urinary tract are at particular risk)
- **asymptomatic bacteriuria**  
 in adults, the incidental finding of significant bacteriuria is generally of little consequence (antibiotic therapy is not value) - with exception:
  - pregnant women **showing a propensity for the asymptomatic bacteriuria to progress to cystitis and acute pyelonephritis**
  - **children with vesicoureteric reflux**

UTI may occur as a single event or may be recurrent as relapses or reinfections  
 Chronic UTI means persistent urinary tract infection

### Localization of infection

- invasive techniques
- non-invasive technique (bacteria in urine of renal origin are coated with antibody)

## 2. Urolithiasis (urinary stone)

The most important **constituents of urinary stones** are:

The most important **constituents of urinary stones** are:

	frequency (%)	radio-opaque
- calcium oxalate + hydroxyapatite	45	++
- calcium oxalate	35	++
- magnesium ammonium phosphate + calcium phosphate ( <b>struvite</b> )	10	++
- uric acid	5	<b>0</b>
- calcium phosphate	1-3	++
- cystine	1-2	+

### Laboratory examination:



- **chemical examination** (stone's composition - usually connected with individual features of metabolism)
- **daily urinary excretion of substances which may be constituents of urinary stones:**

the upper limit of normal

calcium	5 mmol/d	(200 mg/d)
oxalate	0,45 mmol/d	(40 mg/d)
uric acid	4,75 mmol/l	(800 mg/d)
phosphate	38,0 mmol/l	(1,2 g/d)
cystine		(400 mg/d)

other indexes concerning calcium and oxalate excretion:

**calcium/creatinine ratio < 0,69 mmol/mmol (0,21 mg/mg)**

**magnesium/calcium ratio > 0,8 mg/mg**

- **blood concentration of substances which may be constituents of urinary stones:**

calcium	2,25-2,65 mmol/l	
uric acid	180-420 $\mu$ mol/l	(3-7 mg/dl)
phosphate	0,9-1,6 mmol/l	(3-5 mg/dl)
oxalate	33-77 $\mu$ mol/l	(0,3-0,7 mg/dl)

- **urinalysis** (nonspecific abnormalities)

- **erythrocyturia**
- **leukocyturia**-presence of stones in the urinary tract may -maintain UTI, and UTI is one of the contributing factors for stone's precipitation
- **crystals**
- **urine pH**- calcium phosphate and magnesium-ammonium phosphate stones- crystallize in alkaline urine, uric acid and cystine- acid urine
- **specific density**- indirect information about patient's fluid intake

### 3. Nephrotic syndrome

clinical syndrome of diverse etiology characterized by the triad:

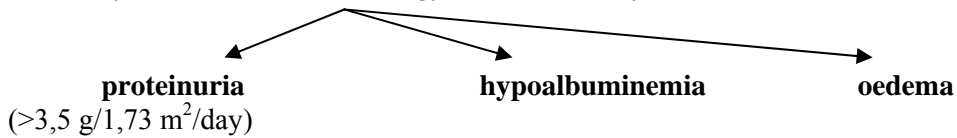

#### Proteinuria

- due to **increase in glomerular permeability**
- proteinuria is influenced by: GFR, plasma conc. of albumin, dietary protein intake

#### Hypoalbuminemia

- due to:
  - proteinuria
  - inadequate hepatic synthesis of albumin
  - increased renal catabolism of proteins

#### Oedema

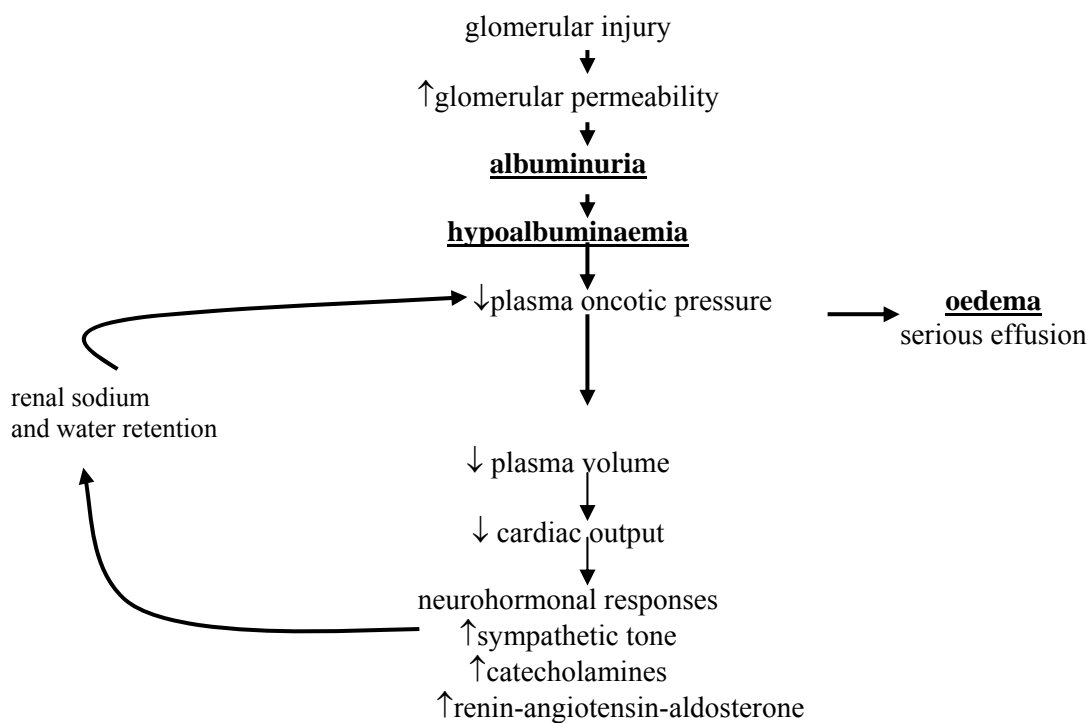

## Hyperlipidemia

characteristic changes observed in serum lipids include:

- increase in low-density lipoproteins (LDL)
- increase in very low-density lipoproteins (VLDL)
- decrease in high-density lipoproteins (HDL)

decreased plasma oncotic pressure and/or the hypoalbuminemia stimulate hepatic lipoprotein synthesis

## Lipiduria

lipid-containing epithelial cells (oval fat bodies)

## Hypercoagulability

is attributed to several factors:

- hypoalbuminemia may induce increased hepatic synthesis of fibrinogen and procoagulant factors and increased platelet aggregation
- high alpha-2-macroglobulin concentration and low plasminogen concentration, which result in a decrease in the plasma fibrinolytic activity
- the presence of hypovolemia and hemoconcentration
- antithrombin III loss

## 4. Glomerulonephritis

mechanisms of immunological renal injury

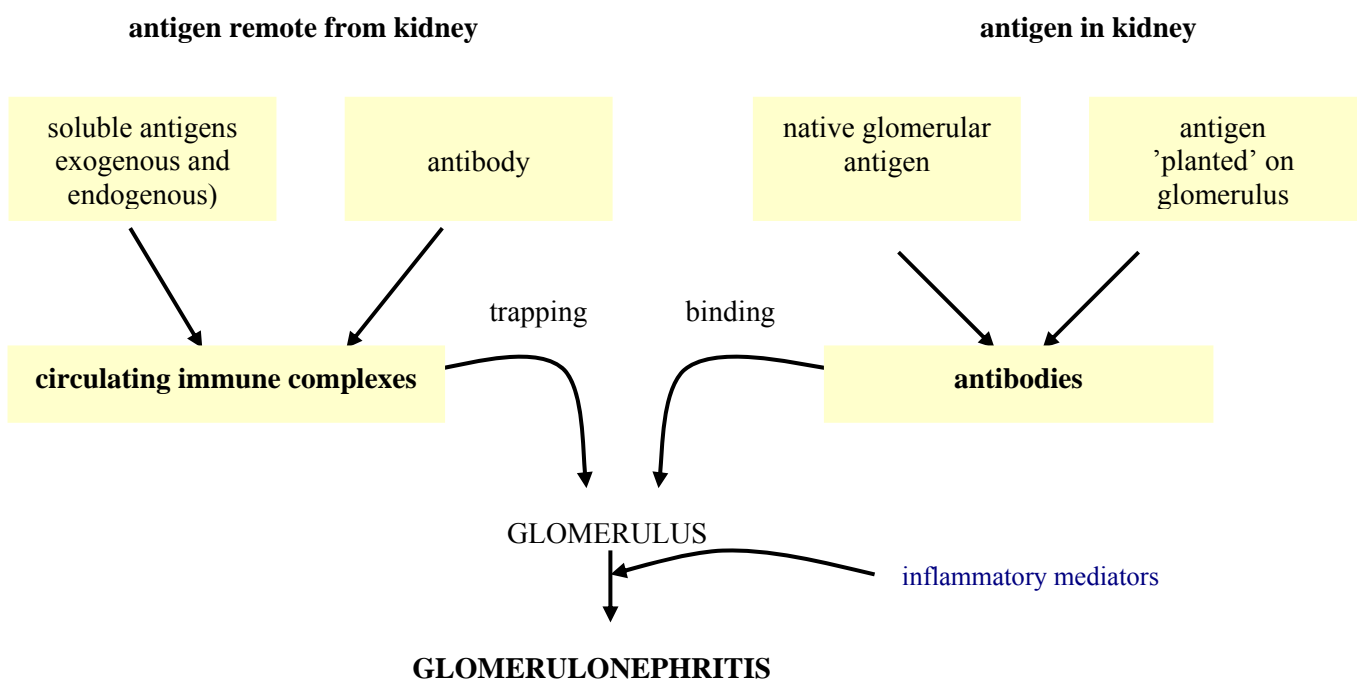

### specific glomerular disease

- acute nephritic syndrome
- rapidly progressive glomerulonephritis (RPGN)
- chronic glomerulonephritis → chronic kidney disease (CKD)
- nephrotic syndrome
- asymptomatic haematuria and-or proteinuria
- recurrent macroscopic haematuria
- acute glomerulonephritis

● **acute nephritic syndrome**

- characterised by:

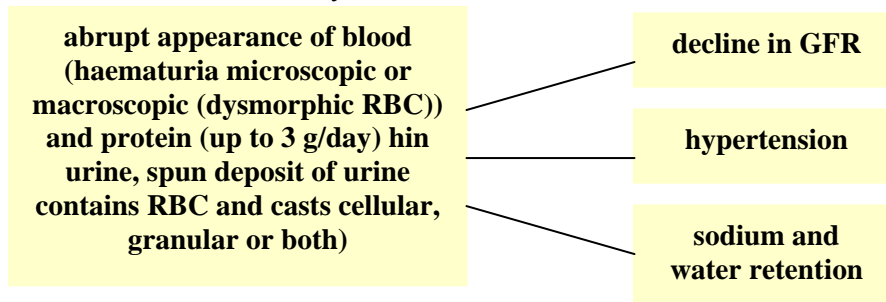

- causes:

<b>Primary postinfectious</b>	<b>Secondary with underlying multisystem disease</b>
<b>Bacterial</b> <i>Streptococci</i> <i>Meningococci</i> endocarditis	SLE Goodpasture's syndrome Henoch-Schonlein purpura Polyarteritis Wegener's granulomatosis
<b>Viral</b> <i>CMV, HBV, EBV</i>	<b>Other</b> idiopathic rapidly progressive glomerulonephritis

● **rapidly progressive glomerulonephritis (RPGN)**

- renal function deteriorates **progressively** over days, weeks or months (usually within the period of 3 months), with urine containing many casts, RBC and proteins, decline in GFR
- causes: multisystem diseases (see above) or infective endocarditis

● **recurrent macroscopic hematuria**

- most frequently affects boys and young males
- is dominated by recurrent episodes of macroscopic hematuria
- sometimes associated with loin pain
- with tendency to exacerbations following intercurrent viral upper respiratory infections or strenuous exercise
- microscopic hematuria persists between attacks and proteinuria is less than 1.5 g/24 hours.
- it is caused by mesangial deposition of IgA in the glomeruli (it is termed IgA nephropathy)

● **acute glomerulonephritis** is suggested by:

- a sudden appearance of hematuria
  - edema
  - hypertension
- sometimes also:
- variable degree of proteinuria
  - renal failure
  - leukocyturia (not connected with UTI)

**Diagnosis:**

evaluation of freshly voided **urine** sample:

- erythrocytes (significant numbers, dysmorphic RBC)
- erythrocyte casts
- proteinuria (mild or nephrotic)

**blood test:**

- BUN, serum creatinine
- serum electrolytes
- complete blood count (RBC- hypochromic-microcytic or normochromic-normocytic anemia, WBC-  $\uparrow/\downarrow$ , PTL $\uparrow/\downarrow$ )
- immunological examination: serum complement components, serologic test for antinuclear antibody, ASL
- bacteriological examination (according to suspected place of infection)

## Kidney failure and clinical basics of hemodialysis

*Dorota Formanowicz MD*

### **ACUTE RENAL FAILURE (ARF) – prerenal, renal, postrenal**

the rapid reduction or cessation of renal function over a period of hours or days causes:

#### **PRERENAL**

- any cause of shock (a low cardiac output)
  - hypovolaemia
  - sepsis
  - cardiogenic
- renal arterial or venous disease: renal artery stenosis, renal vein thrombosis
- inappropriate renal vasoconstriction

#### **RENAL**

- acute tubular necrosis, acute glomerulonephritis, acute tubulointerstitial disease, exo/endogenous nephrotoxins

#### **POSTRENAL**

- any causes of obstruction (stone, pelvic malignancy, retroperitoneal disease)

### **1. PRERENAL - decrease in blood flow → reabsorption of salt and water**

- **urine sodium concentration <10-25 mEq/l**
- **FE<sub>Na</sub> <1%**
- **the urine osmolality > 500 mOsm/l**
- **no parenchymal damage**
- **urinalysis is normal** (sometimes only granular or hyaline casts, minimal proteinuria, high specific gravity)
- urine creatinine concentration rise → **high urine/plasma creatinine ratio**
- urine urea concentration rise → **high urine/plasma urea ratio**
- during low flow conditions, more urea is reabsorbed → **high plasma urea/creatinine ratio**

feature	favors prerenal cause	favors renal cause
◆ identifiable prerenal factor (shock, hypovolaemia)	yes	no
◆ urine	•protein	+
	•RBC	0
	•WBC	0
	•casts	0/+
	osmolality (mosmol/kg/H <sub>2</sub> O)	>500
	sodium (mmol/l)	<20
◆ urine/blood urea nitrogen (BUN) ratio	>8	<3
◆ urine/plasma creatinine ratio	>40	<20
◆ FE <sub>Na</sub>	<1%	>1%



## 2. RENAL

### Acute tubular necrosis (ATN)

- Urinalysis- granular casts, renal tubular epithelial cells, small amounts of protein
- **BUN** - rate of rise of BUN is about 10-20 mg/dl/day (in states associated with increased synthesis or decreased elimination of BUN it may exceed 100 mg/dl/day)
- **Serum creatinine** - rate of rise of serum creatinine is about 0.5-1.0 mg/dl/day
- **Metabolic acidosis** - retention of hydrogen ions (in the form of sulphuric and phosphoric acids) results in a decrease in the serum bicarbonate conc.
- **Hyperkalemia** - serious and life-threatening complication of ARF, may be aggravated by exogenous potassium load (potassium-containing antibiotics, salts substitutes), drugs that impair renal or extrarenal potassium handling, metabolic acidosis, tissue breakdown
- **Hyponatremia** - result of excessive water ingestion
- **Hypocalcemia** - reasons: hypoalbuminemia, hyperphosphatemia, resistance to parathyroid hormone, reduction in active component of vit. D
- **Hypermagnesemia** - rarely clinically significant
- **Hyperuricemia** - may accompany ATN
- **Hematologic alterations:**
  - **anemia** (decreased erythropoiesis, hemolysis, shortened RBC survival, blood loss)
  - **bleeding diathesis** (in ATN alterations in platelet aggregation and adhesiveness)
  - **alteration in the immune system** (lymphopenia, impaired cellular immunity)

### 3. POSTRENAL ARF- similar laboratory like during prerenal failure are found

#### Diagnostic features distinguishing between ACUTE RENAL FAILURE AND CHRONIC KIDNEY DISEASE

##### Favors ACUTE

- known recent onset
- known precipitating factors
- near normal hematology
- normal size kidneys (ultrasound, X-rays)

##### Favors CHRONIC

- history of nocturia
- pigmentation
- normochromic anemia
- small kidneys
- bone disease (radiographic and biochemical)

## CHRONIC KIDNEY DISEASE (CKD), CHRONIC RENAL FAILURE (CRF)

### National Kidney Foundation (NKF) definition of CKD:

**GFR < 60 ml/min/1.73 m<sup>2</sup> for ≥ 3 months, with or without kidney damage**

or

**kidney damage for ≥ 3 months, as defined by structural or functional abnormalities of the kidney, with or without decreased GFR, manifested by either**

- pathologic abnormalities
- markers of kidney damage, including abnormalities in the composition of the blood, or urine abnormalities in imaging tests

## Causes of CKD:

- vascular (**hypertensive nephrosclerosis**, renal artery stenosis, systemic sclerosis, vasculitis)
- glomerulopathy
- tubulointerstitial nephropathy
- infection and/or reflux (chronic pyelonephritis, renal tuberculosis)
- cystic disease
- obstructive nephropathy
- diabetic nephropathy**
- amyloid
- renal dysplasia, hypoplasia, agenesis

assessment of the patient who appears to have CKD

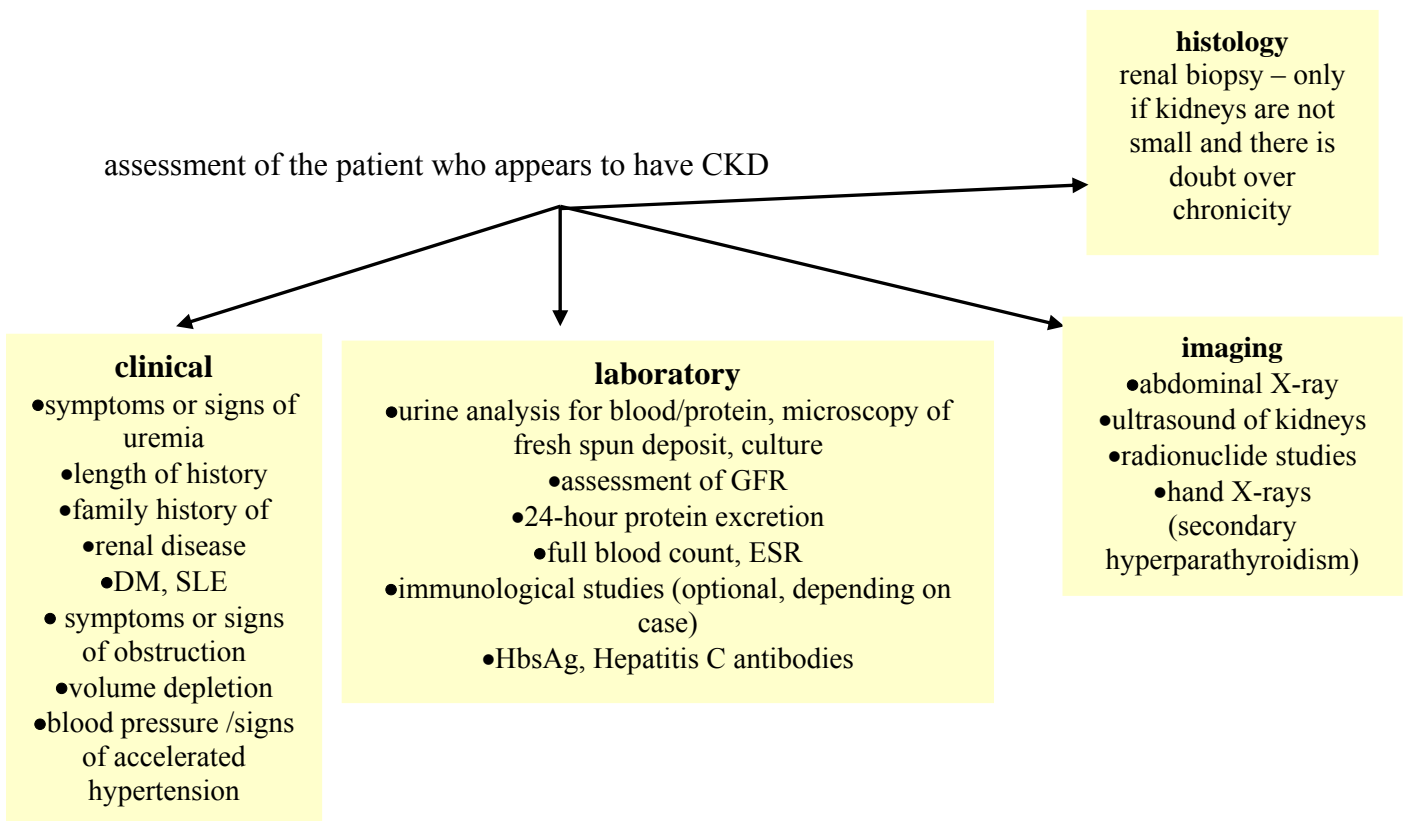

**Staging and management of CKD (according to Kidney Disease Improving Global Outcomes (KDIGO, 2005))**

Stage	Description	GFR ml/min/1.73 m <sup>2</sup>	Classification of CKD by severity	Related terms	Action
			Clinical presentation		
1	kidney damage with normal or ↑ GFR	≥ 90	markers of damage (nephritic syndrome, nephritic syndrome, tubular syndromes, urinary tract symptoms, asymptomatic radiologic abnormalities, hypertension due to kidney disease)	albuminuria proteinuria hematuria	<ul style="list-style-type: none"> <li>◆ diagnosis and treatment</li> <li>◆ treatment of comorbid conditions</li> <li>◆ slowing progression</li> <li>◆ cardiovascular disease risk reduction</li> </ul>
2	kidney damage with mild ↓ GFR	60-89	mild complications	albuminuria proteinuria hematuria	◆ estimating progression
3	moderate ↓ GFR	30-59	moderate complications	chronic renal failure, early renal insufficiency	◆ evaluating and treating complications
4	Severe ↓ GFR	15-29	severe complications	chronic renal failure, advanced renal insufficiency, pre-ESRD (end-stage renal disease)	◆ preparation for renal replacement therapy
5	Kidney failure	<15 or dialysis	uremia, cardiovascular disease (CVD)	renal failure, uremia, ESRD	◆ renal replacement (if uremia present)

**STAGES 1-4 of CKD** → conservative management

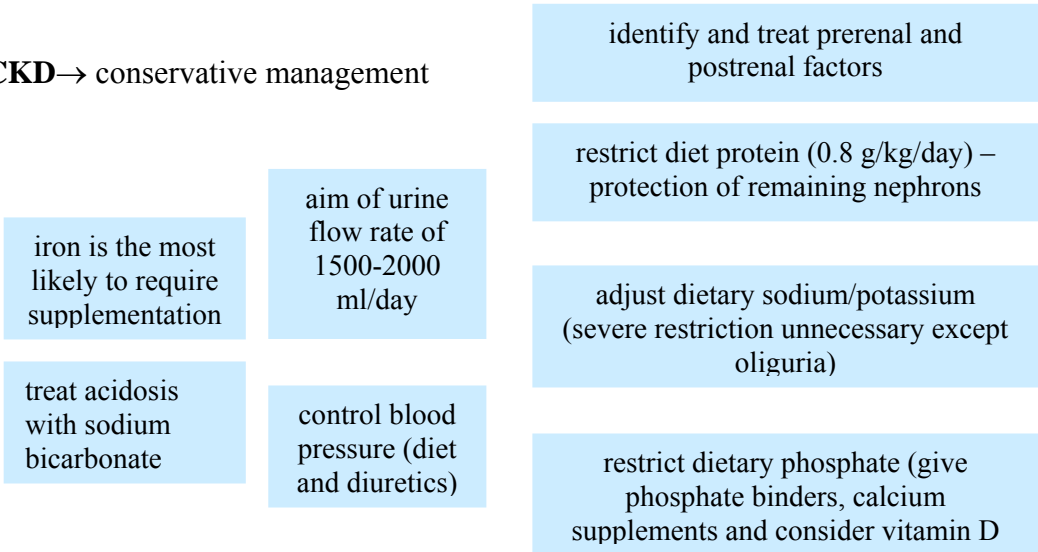

**STAGE 5 of CKD** → dialysis treatment (see below)

**Creatinine serum concentration is increased (>1.2 mg/dl) only when GFR ranges between 59 and 15 ml/min/1.73 m<sup>2</sup> (in stages 3 –5 of CKD)**

## Uremia (uremic syndrome) – stage 5 of CKD

- it is a group of symptoms and signs, some or all are found in patients with serious reduction of excretory capacity (i.e. GFR), from any cause
- it rarely manifests itself clinically until the GFR has fallen to 20% of normal value or less
- symptoms and signs of uremic syndrome results (mainly) from toxic accumulation of waste products, depletion of essential compounds and failure of biosynthetic function of kidneys:
- biochemical features:
  - usually GFR < 10 (15) ml/min
  - usually serum creatinine > 8(12) mg/dl
  - usually BUN > (60) 100 mg/dl

●**nervous system**: fatigue, malaise, depression, involuntary movements, nausea, fits, coma, priuritus, paraesthesiae, neuropathy

●**cardiopulmonary**: pericarditis, pleurisy, dyspnoea, Kussmaul breathing

●**dermatological**: priuritus, purpura, pallor, pigmentation, urea frost

●**gastrointestinal**: anorexia, nausea, vomiting, GI bleeding, constipation, diarrhoea, peptic ulceration, angiodysplasia, colitis, foetor

●**hematological**: anemia (normochromic, normocytic), bleeding (disordered platelet function)

- ◆ **uraemic toxins** (PTH, gastrin, glucagon, calcitonin, purine metabolites, aliphatic and aromatic amines, phenols and indoles (so-called ‘middle molecules’ – compounds of molecular weight 500-5000 Da)

### Haematopoietic system in uremia

- **normochromic normocytic anemia**

- the following contribute to the **anemia**

decreased production of erythropoietin by the decreased kidney

direct marrow suppression by uremic toxins

iron and folic acid deficiency

shortened red blood cell survival

bleeding from capillaries and due to abnormal platelet function

decreased production of erythropoietin by the decreased kidney



## ANEMIA DIAGNOSIS IN PATIENTS WITH CKD

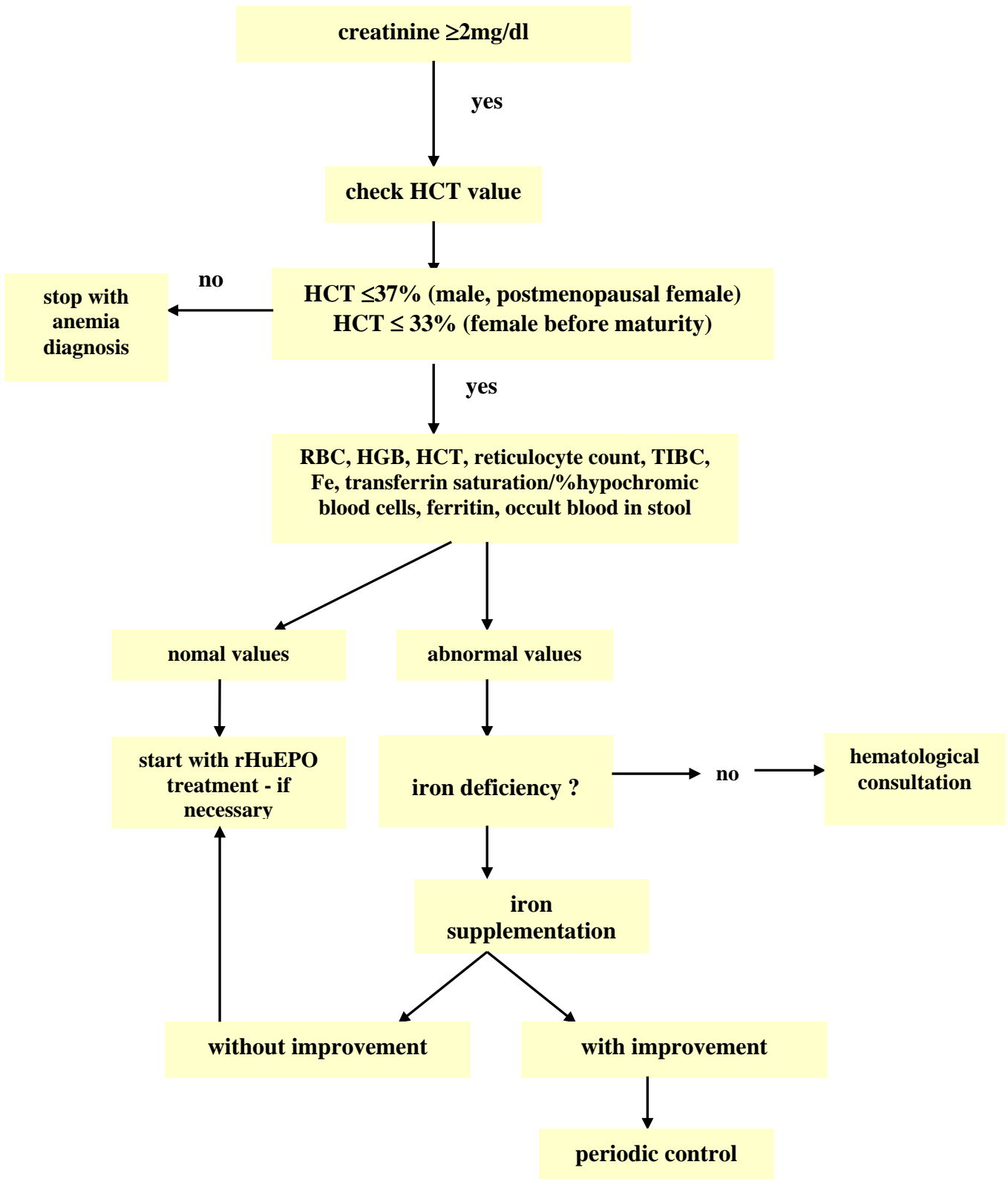

## Cardiovascular system in uremia

- the most common cause of death in patient with renal failure, regardless of whether they are treated by hemodialysis, peritoneal dialysis or transplantation

## Skeletal and mineral metabolism in uremia

**Hyperphosphatemia** due to marked decrease in GFR

**Hypocalcemia** secondary to:

- hyperphosphatemia – phosphate retention – a consequence of decreasing filtered load of phosphate
  - decreased ability of PTH to mobilize calcium from bone
  - decreased serum levels of 1,25(OH)<sub>2</sub>vit. D<sub>3</sub>
  - decreased calcium absorption from gastrointestinal tract
- metabolic acidosis present tends to increase the fraction of ionized calcium

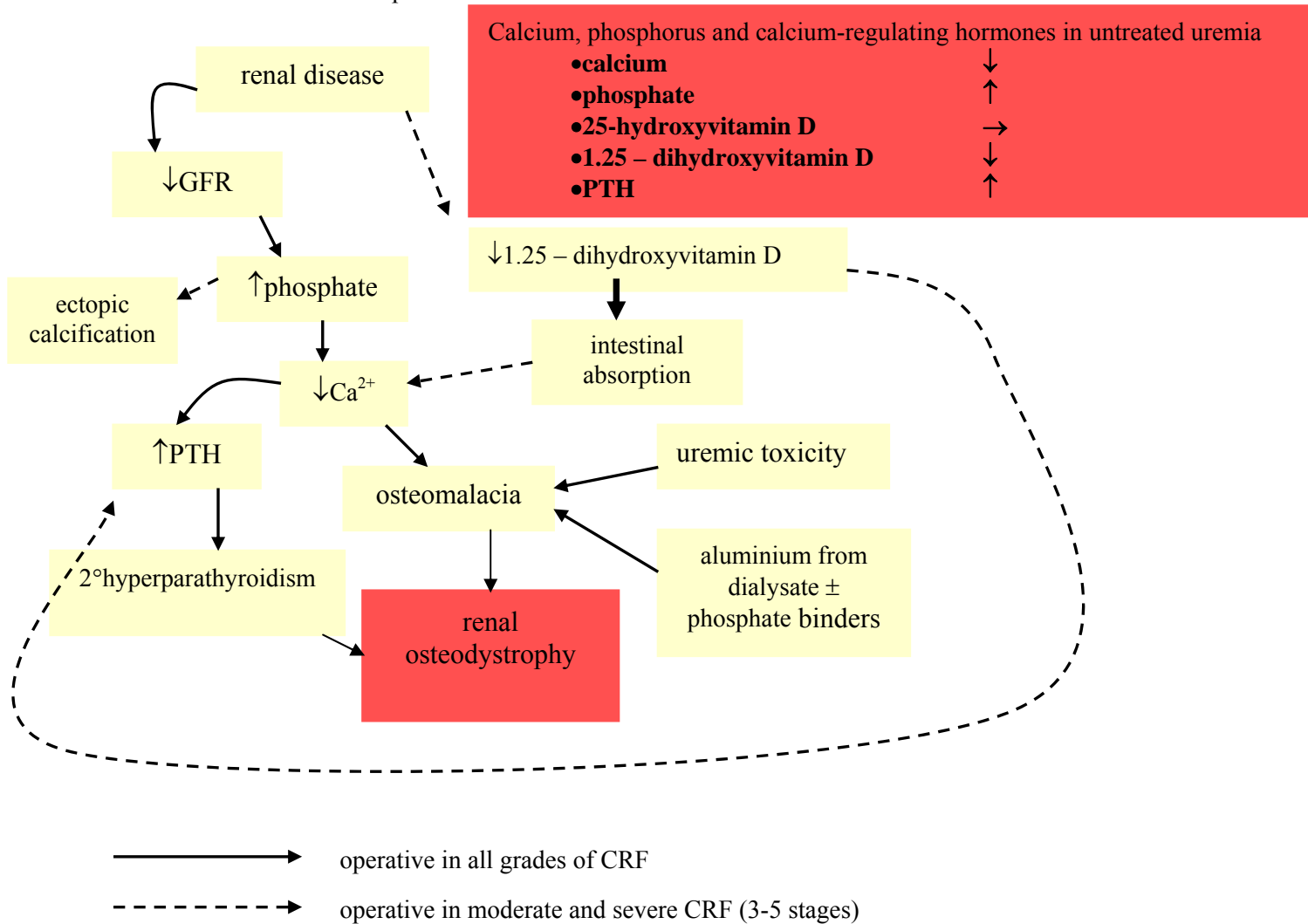

## Acid-base balance :

- hydrogen ion synthesis **increased**
- hydrogen ion excretion **decreased**

Two types of acidosis in CKD:

- hyperchloremic acidosis
- metabolic acidosis

## Metabolic alteration

### •disorders of **nitrogen** metabolism- **hipoproteinemia**

- protein intake **decreased**
- protein catabolism **increased**
- protein losses **increased**

### •disorders of **carbohydrate** metabolism

- in fasting state **glucose normal or slightly elevated**
- after oral or intravenous administration of glucose loads **carbohydrate tolerance is impaired (mild)**
- factors responsible for these abnormalities:
  - resistance of skeletal muscle to insulin
  - increased gluconeogenesis
  - increased hepatic glucose release
  - tendency of uremia per se to inhibit insulin secretion

### •disorders of **lipid** metabolism

- plasma cholesterol level **normal**
- plasma triglycerides and VLDL level **elevated**
- plasma HDL and LDL **decreased**

### ◆ **Magnesium**

**normal or elevated**

- serum magnesium level rises in response to acidosis, tissue trauma, administration of vit. D or antacids containing magnesium

### ◆ **Potassium excretion**

- increase in potassium excretion per nephron
- increase in potassium excretion per intestine

Hyperkalemia observed in CKD may be due to:

- acidosis
- $\beta$ - blockers
- ACE-I administration
- oliguria
- increase in potassium intake



## CLINICAL BASICS OF HEMODIALYSIS

### Physical principles of dialysis treatment

#### Hemodialysis (HD)

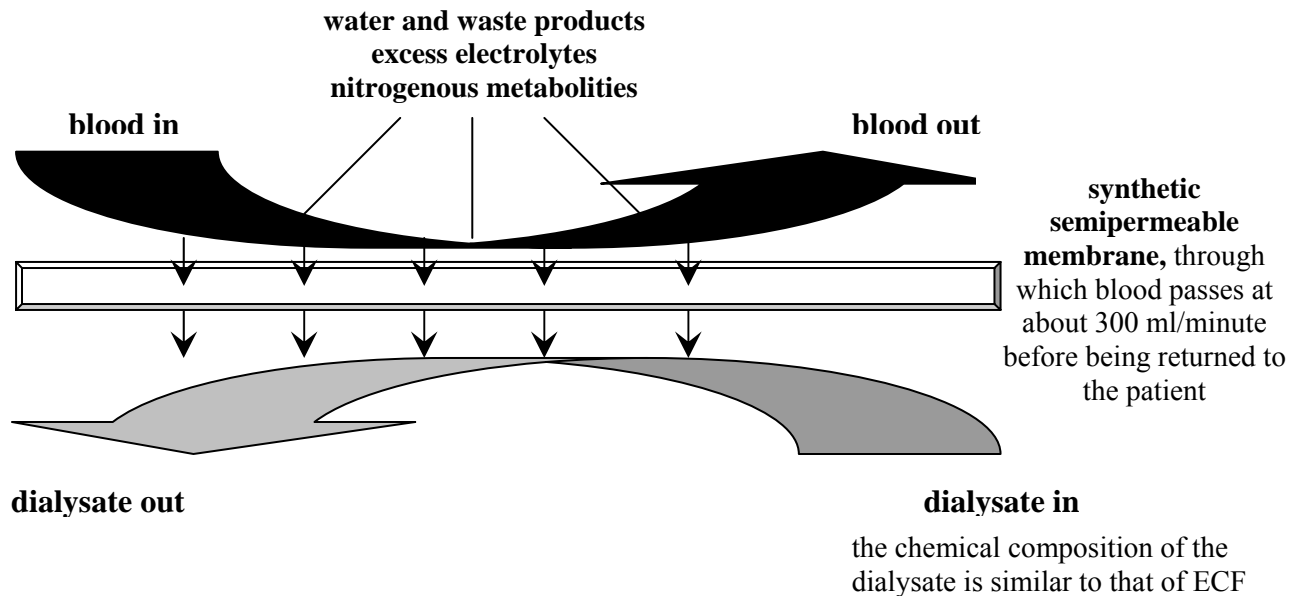

- urea (so-called ‘small molecule’), and other waste products (so-called ‘middle molecule’ (see above)), which are present only in plasma, diffuse down a concentration gradient across the membrane into the dialysate
- changes in the composition of the dialysate and in the hydrostatic pressure gradient across the membrane allow “tailoring” of the rate of removal of a variety of substances according to the patient’s needs
- adequate access to the circulation is a prerequisite – percutaneous placement of large-bore central venous catheters (short-term treatment only), or by creation of arteriovenous fistula (usually at the wrist), thus increasing forearm blood flow and allowing large-bore needles to be placed in forearm veins (long-term treatment)
- treatment is intermittent, typically three sessions of 4 hours each per week

#### Peritoneal dialysis

- the dialysate is fed into peritoneal cavity via a flexible tube, and the peritoneum itself acts as a semi-permeable membrane
- the dialysate is replaced with fresh fluid when chemical equilibrium is reached
- it usually takes the form of continuous ambulatory peritoneal dialysis (CAPD) in which 2-litre exchanges are performed four times a day
- the technique is simple to learn and the vast majority of patients can carry out and supervise their own treatment at home

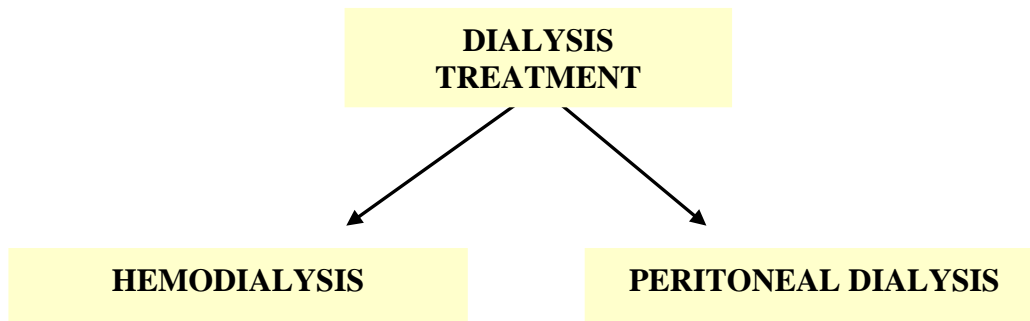

## INDICATIONS FOR DIALYSIS TREATMENT

### 1. UREMIC SYNDROME:

- ◆ **neurological:** coma, stupor, fatigue, abnormal mentation, fits, myoclonus, asterixis, peripheral neuropathy
- ◆ **cardiovascular/pulmonary:** pericarditis, pleurisy, volume overload unresponsive to conservative measures
- ◆ **skin:** pruritus
- ◆ **gastrointestinal:** anorexia, nausea, vomiting, unremitting diarrhoea
- ◆ **metabolic:** unremitting acidosis

### 2. CHEMISTRY

- ◆ **plasma urea more than 100-150 mg/dl**
- ◆ **severe symptomatic metabolic acidosis ( $\text{HCO}_3^- < 13 \text{ mmol/l}$ ,  $\text{pH} < 7.2$ )**
- ◆ **hyperkalemia (potassium concentration  $> 6.5 \text{ mmol/l}$ )**
- ◆ **creatinine clearance  $< 10\text{-}12 \text{ ml/min}$**
- ◆ **serum creatinine  $> 9 \text{ mg/dl}$ , and if CKD is caused by diabetic nephropathy  $> 5 \text{ mg/dl}$**

### 3. SEVERE HYPOVOLAEMIA WITH HYPERTENSION AND/OR PULMONARY OEDEMA

3. **THE NEED TO REMOVE FLUID** to allow intensive feeding with high energy/high nitrogen diets or total parenteral nutrition

The optimum time to convert patient with CKD from conservative management to dialysis is judged clinical decision and is reached just before the development of uremic complications

**Contraindications to dialysis treatment** (especially in case of long-term treatment)

- malignant neoplastic diseases with metastases
- deep mental handicap

**Limitations of dialysis treatment**

1. The *average* clearance of urea or creatinine achieved by hemodialysis (12 hours treatment per week) is only 6 ml/minute, and by CAPD 7 ml/minute, compared with approx.100-120 ml/minute by normal kidneys.
2. The permeability characteristics of the artificial membrane in HD and, the peritoneum CAPD are inferior to those of the physiological glomerular sieve.
3. Dialysis has no equivalent of ‘tubular action’; the dialysis membrane should be permeable enough to allow waste products to cross and not so permeable that excess loss of physiologically important compounds – in practice, the membrane fails on both counts
4. The dialysis has essentially no adaptive capability.
5. Endocrine functions of the kidney are not provided by dialysis. The anemia (erythropoietin) and osteodystrophy (1.25 dihydroxyvitamin D) continue.

**Minimal spectrum of assessed parameters during one-year period of HD treatment**

- HCT	}	<b>once a week-once a month</b>
- sodium, potassium		
- Ca <sup>2+</sup> , phosphate	}	<b>once a week</b>
- blood cell count		
- serum urea (before and 30 minutes after HD)	}	<b>once a month</b>
- glucose		
- GOT, GPT	}	<b>4 times a year</b>
- lipids		
- proteinogram		
- coagulogram		
- HBs, anty-HBs, HCV, HIV		
- bilirubin		
- CRP		
- ferritin		
- PTH	}	<b>twice a year</b>
- chest X-ray		
- urine culture	}	<b>once a year</b>
- densitometry		

# Clinical enzymology and liver function disorders

Miłoslawa Zowczak-Drabarczyk MD

## Serum aminotransferases

Alanine aminotransferase ( **ALT**):

- is an enzyme **predominantly found in liver** (significant amounts are also present in kidney, with lesser amounts in heart and skeletal muscle),
- is **exclusively cytoplasmic**.

Aspartate aminotransferase ( **AST**):

- is an enzyme primarily found in **heart, liver, skeletal muscle, kidney and RBCs**,
  - both **mitochondrial (60-80%)** and **cytoplasmic (20-40%)** forms of AST are found in all cells
- approximately 80% of AST in hepatocytes appears to be located in mitochondrial membrane

### Factors affecting AST and ALT activity, other than liver injury:

factor	AST	ALT	comments
Time of day		45% variation during day, highest in afternoon, lowest at night	Similar in liver disease and health
Day-to-day	5-10% variation from one day to next	10-30% variation from one day to next	Similar in liver disease and health
Race/gender	15% higher in African-American men		
BMI	40-50% higher with high BMI	40-50% higher with high BMI	Direct relationship between weight and AST,ALT
exercise	Threefold increase with strenuous exercise	20% lower in those who exercise at usual levels than in those who do not exercise or exercise more strenuously than usual	Effect of exercise seen predominantly in men; minimal differences in women(<10%), enzymes increase more with strength training
Hemolysis, hemolytic anemia	Significant increase	Moderate increase attributable to release from red cell	Dependent on degree of hemolysis, usually severalfold lower than increases in LDH
Muscle injury	Significant increase	Moderate increase	Related to amount of increase in CK
Renal failure	Significantly lower	Significantly lower	

- **ALT** has been **used** predominantly to help **confirm liver origin of an AST increase**.
- **ALT** is more specific for **detecting liver disease in nonalcoholic, asymptomatic patients**
- **Pyridoxine deficiency**, common in **alcoholics**, **decreases hepatic ALT** activity

- Patients who chronically abuse alcohol, regardless of the extent of their underlying liver disease, had more consistent mitochondrial AST elevations than other patients (alcohol induces release of mitochondrial AST); values dropped more than 50% in abstinence for more than one week.
- AST is used for monitoring therapy with potentially hepatotoxic drugs

- **ALT and AST increase 10 times the upper reference limit**, or more, in **acute viral hepatitis**
- Chronic elevation of ALT/AST in asymptomatic patients may have several causes including alcohol or medication use, chronic viral hepatitis, primary hemochromatosis or nonalcoholic fatty liver disease.
- **ALT** is constantly **higher than AST** with all causes of acute and chronic **hepatocellular injury** (AST/ALT ratio<1) **with exception of alcoholic** liver injury and **liver cirrhosis** (AST/ALT>1)

## Alkaline phosphatase (ALP)

- Is found (in decreasing order of abundance) in **placenta**, ileal mucosa, kidney, **bone and liver**. The bulk of serum ALP of normal patients is made up of liver and bone ALP.
- **ALP** in the liver exists predominantly **in the biliary tract** and is therefore a **marker for biliary dysfunction**
- Cholestasis stimulates synthesis of ALP and release from cell membranes
- The three liver conditions most frequently associated with **ALP elevation** are: **extrahepatic** (common bile duct) **biliary tract obstruction**, **intrahepatic biliary tract obstruction** due to acute liver injury, and **liver space-occupying lesions** (e.g. tumor, abscess, granuloma).
- **Common bile duct obstruction**, **metastatic tumor to the liver**, and uncommon condition of **primary biliary cirrhosis** are the most frequent etiologies for persistent **ALP elevation more than three times** upper reference limit.
- Elevation less than three times the upper limit is some evidence against complete extrahepatic obstruction.

## Factors affecting ALP activity, other than liver injury

factor	change	comments
Day-to-day	5-10%	Similar in liver disease and health
Food ingestion	Increases as much as 30 IU/L	Attributable to intestinal isoenzyme
Race/gender	10-15% higher in African-American women and men	
BMI	25% higher with increased BMI	
pregnancy	Increases up to two- to three-fold in third trimester	Attributable to placental isoenzyme
smoking	10% higher	
Oral contraceptives	20% lower	
other	High in bone disease, tumors producing ALP	Can be separated from liver causes by ALP isoenzymes and/or normal GGT

## Gamma-glutamyl transferase (GGT)

- GGT enzyme is located mainly in liver cell membranes.
- **GGT activity in serum** comes predominantly from **liver**
- **GGT** is affected by both acute **liver cell damage** and **biliary tract obstruction**.
- Its major use is to discriminate the source of elevated ALP ( i.e., **if ALP is elevated, measurement of GGT activity is a good indicator of liver source but does not rule out coexisting bone disease**).
- **GGT** is **increased** an average of **10-12-fold** above the upper reference limit in **cholestasis**
- GGT appears to increase in cholestasis by the same mechanisms as does ALP
- **GGT** is **often increased in alcoholics** (70-80%) even without liver disease, in some obese people, in the presence of high concentrations of therapeutic drugs such as **acetaminophen**, and even in the absence of any apparent liver injury.

## Factors affecting GGT, other than liver injury

factor	change	comments
Day-to-day	10-15%	Similar in liver disease and health
race	Approximately double in African Americans	
BMI	25% higher with mild increase in BMI; 50% higher with BMI>30	
Food ingestion	Decreases after meals	
drugs	Increased by furosemide, heparin, methotrexate, phenobarbital, phenytoin, carbamazepine, oral contraceptives	Values up to 2 times reference limits are common, may be up to 5 times, especially with phenytoin
smoking	10% higher with 1 pack/day; approximately double with heavier smoking	
other	Patients with DM, hyperthyroidism, rheumatoid arthritis and obstructive pulmonary disease often have increased GGT activity	The reasons are largely obscure
Alcohol consumption	Direct relationship between alcohol intake and GGT	May remain increased for weeks after cessation of chronic alcohol intake

## Lactate dehydrogenase (LD)

- LD can be fractionated into five isoenzymes using various methods (e.g. electrophoresis).
- **LD5** is found predominantly **in liver and skeletal muscle**.
- Total LD activity is significantly elevated in acute hepatocellular damage (e.g. hepatitis).
- the **large increase of total LD to levels of 500 IU/L** or more **combined with an increase in alkaline phosphatase (ALP) to levels above 250 IU/L** in the absence of other dramatic abnormalities in other liver function enzyme levels indicates space-occupying lesions of the liver, most often **metastatic carcinoma**

## Lipoprotein LpX:

- **Lp X** is a normal **component of bile**,
- its **presence in serum** is an abnormal finding and indicates **obstructive biliary disease**,
- one possible explanation for the origin of LpX is regurgitation of biliary lipids.

## Classification of jaundice

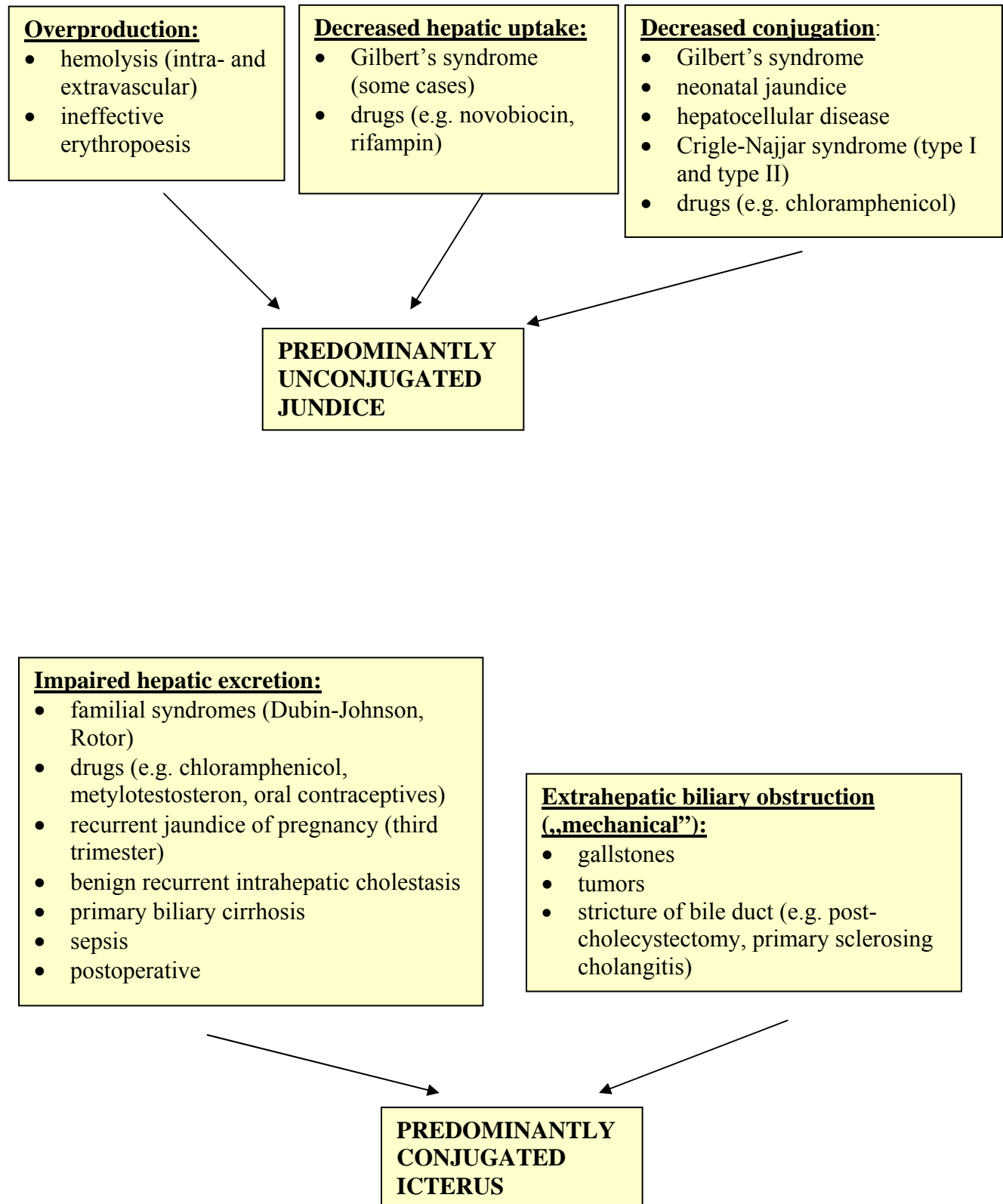



## Most suitable laboratory markers of liver disorders

### HEPATOCELLULAR INJURY:

- AST and ALT
- bilirubin in serum
- urobilinogen in urine
- serum albumin
- prothrombin time
- GGT,
- LDH
- Viral Ab/Ag

### BILIARY OBSTRUCTION:

- ALP
- GGT
- bilirubin in serum
- bilirubin in urine
- Lp X
- 5'-Nucleotidase

### TOXIC INJURY e.g. ALCOHOL, DRUGS:

- AST
- GGT

## Hemochromatosis

- An increase in the quantity of iron storage in the body is called ***hemosiderosis*** (e.g. alcoholic liver disease, chronic HCV infection, non-alcoholic steatohepatitis).
- ***Hemochromatosis(ph)*** is an increase in total body iron stores with iron deposition in parenchymal tissues that ultimately leads to functional impairment of most severely affected organs: liver→cirrhosis, pancreas→diabetes mellitus, heart→cardiomyopathy, joints→arthritis, etc.
- Signs and symptoms of ph usually develop between the ages of 40 and 60.

### Hemochromatosis:

————→ **acquired**- exogenous iron overload due to repeated blood transfusions or excessive dietary iron ingestion)

————→ **hereditary, primary (ph)**- frequent genetic disorder (1/200- 1/400) and the most frequent metabolic liver disease with multisystem involvement.

### First-line screening tests:

- *percent of transferrin saturation and*
- *serum ferritin concentration*

### Definitive tests:

- ***genetic testing*** (autosomal recessive trait: C282Y mutation of the HFE gene in over 90% of ph cases) and
  - ***liver biopsy*** but ***magnetic resonance imaging*** can also be alternatively used to estimate liver iron content

## Iron indices in normal subjects and in patients with symptomatic hemochromatosis:

	Normal	Symptomatic hemochromatosis:
<b>Plasma iron (ug/dL)</b>	50-150	180-300
<b>Total iron binding capacity (ug/dL) TIBC</b>	250-375	200-300
<b>Percent of transferrin saturation</b>	20-40	50-100
<b>Serum ferritin (ng/mL)</b>	10-200	400-6000
<b>Urinary iron after 0,5 gm desferrioxamine</b>	0-2	9-23
<b>Liver iron (ug/100mg dry weight)</b>	30-140	600-1800

## References

1. Cecil Essentials of Medicine. 3<sup>rd</sup>.ed. W.B. Saunders Company. Philadelphia 1993.
2. Harrison's Principles of Internal Medicine. 16<sup>th</sup> ed. McGraw-Hill Health Professions Division. 2004.
3. Henry J.B. Clinical Diagnosis and Management by Laboratory Methods. 20<sup>th</sup> ed. W.B. Saunders Company. Philadelphia 2001.
4. Dominiczak M.H. Seminars in Clinical Biochemistry
5. Ravel R. Clinical Laboratory Medicine. Clinical Application of Laboratory Data. 6<sup>th</sup> ed. Mosby-Year Book. 1995.
6. Dufor R.D., Lott J.A., Nolte F.S., Gretch D.R., Koff R.S., Seeff L.B. Diagnosis and monitoring of hepatic injury.I. Performance characteristics of laboratory tests. Clinical Chemistry 2000, 46: 2027-2049.
7. Dufor R.D., Lott J.A., Nolte F.S., Gretch D.R., Koff R.S., Seeff L.B. Diagnosis and monitoring of hepatic injury.II. Recommendations for use of laboratory tests in screening, diagnosis, and monitoring. Clinical Chemistry 2000, 46: 2050-2068.

# The application of laboratory methods in the diagnosis and management of ischemic heart disease

Hanna Kara-Perz MD

## Myocardial ischemia

**Ischemia refers to lack of oxygen due to inadequate perfusion, which results from an imbalance between oxygen supply and demand.**

### Causes of myocardial ischemia:

- Atherosclerotic obstructive coronary artery disease
- Collagen vascular disease
- Congenital coronary artery anomalies
- Hereditary disorders
- Dissection
- Coronary artery embolism
- "Functional causes" in the absence of anatomic coronary artery disease
  - increased myocardial oxygen demand
  - decreased myocardial oxygen supply

### Some factors that influence myocardial metabolism

#### Oxygen demand

- heart rate
- afterload
- contractility
- wall tension

#### Oxygen supply

- oxygen content of the blood
- volume of blood flowing through the coronary arteries per unit of time

## Coronary artery disease (CAD)

### Stable angina pectoris

### Unstable angina pectoris

- new onset (<2 months) angina that is severe and/or frequent ( $\geq 3$  episodes per day)
- accelerated angina
- angina at rest (with pain lasting more than 20 min)
- variant angina (episodic focal spasm of coronary artery)
- non-Q myocardial infarction
- unstable angina post MI (after more than 24 h after MI)

**The diagnosis is made on the basis of the medical history, ST-segment changes, and absence of increased serum cardiac markers.**

### Standard laboratory test

**Lipid profile and carbohydrate tolerance** should be considered in patients with CAD

## Myocardial infarction (MI)

MI generally occurs when there is abrupt decrease in coronary blood flow following a thrombotic occlusion of coronary artery previously narrowed by atherosclerosis

### Clinical presentation

- **frequency is highest in the morning** within a few hours of awaking
- **pain** is the most common presenting complaint (features of pain: heavy squeezing, crushing, stabbing, burning)

- pain is often accompanied by weakness, sweating, nausea, vomiting, anxiety, and sense of impending doom
- pain of MI can simulate pain from acute pericarditis, pulmonary embolism, acute aortic dissection, costochondritis
- **SBP** usually declines 10-15 mmHg from the preinfarction state

## Typical serum cardiac markers

### Creatine kinase (CK)

- Composed of two **subunits: B (brain) and M (muscle)**
- **3 isoenzymes:** (localized in cytoplasm, or connected to myofibrils)

**CK-BB (CK-1)** – brain, prostate, intestine, lungs

**CK-MB (CK-2)**- heart, skeletal muscle

**CK-MM (CK-3)**- skeletal muscle, heart

**CK-Mt** - isoenzyme localized in mitochondria

- **macromolecular forms of CK**
  - makro CK-type 1** has been identified to be CK-BB linked with IgG
  - makro CK-type 2** has been identified as CK-Mt oligomer
- **CK isoforms**
  - Subunits B and M contain lysine on the C-end, but only the M subunit may be hydrolyzed by carboxypeptidase in blood
  - CK-3<sub>2</sub>, CK-3<sub>1</sub>, CK-2<sub>1</sub>- serum isoforms
  - CK-3<sub>3</sub>, CK-2<sub>2</sub>- tissue isoforms (genetically determined)

### Creatine kinase activity

Increased CK activity is also observed in:

- skeletal muscle disorders (including damage secondary to trauma, **intramuscular injections!**, prolonged immobilization, surgery)
- after physical effort
- after electric cardioversion, cardiac catheterization
- hypothyreosis

### CK-MB activity

Enzyme	Activity [IU/L]	Increase	Onset of increase	Peak value	Return to the normal range
<b>CK-MB</b>	<b>25</b>	<b>2-10 x</b>	<b>4-8 h</b>	<b>1-2 day</b>	<b>2-3(4) day</b>

- "gold standard"
- **specificity** is very high, but not 100%
- activity may be increased in:
  - skeletal muscle diseases
  - renal failure
  - some neoplasms

- **CK-MB index = CK-MB act/CK act x 100%**

We calculate this index to increase specificity as for myocardium

- **Diagnostic sensitivity**  
30% in the 4<sup>th</sup> h from the first symptoms
- **Subsequent measurement** of CK-MB activity increases both sensitivity and specificity

## CK-MB mass

- Evaluation of CK-MB mass should replace CK-MB activity

onset	4 (3,5-5,5) h
peak value	14 (11,5-15,5) h
decrease to normal range	87 (68-96) h

CK-MB mass **is not useful in late stage of MI**, because increased results may be observed only for about 30 h

- **specificity**- very high, but not 100%  
CK-MB mass may be increased in:  
skeletal muscle diseases

- **diagnostic sensitivity**

in the 4<sup>th</sup> h of MI - 50%

after 6 h -75%

after 8 h -90%

- CK-MB mass has **great effectiveness in excluding of MI** (when there is no increase of CK-MB mass within 8 h from the first stenocardial symptoms it allows to exclude MI in 93-95%)
- CK-MB mass is **useful in evaluation of effectiveness of fibrinolytic therapy**

## Myoglobin

- The first serum cardiac marker that rises above the normal range after MI (early diagnosis of MI)

onset	3,3 (2,5-4,3) h
peak value	6,0 (4,0-8,5) h
decrease to normal range	20 (15,5-39,9) h

Myoglobin **is not useful in late stage of MI**, because increased results may be observed only for about 12-15 h

- **specificity**- lack of cardiac specificity
- Myoglobin conc. may be increased in:  
-skeletal muscle diseases and injury  
-renal failure  
-after physical effort

Evaluation of myoglobin should be connected with evaluation of the other cardiac-specific markers

- **diagnostic sensitivity**

after 2,5 h after the first symptoms of MI – 30%

in the 4<sup>th</sup> h of MI- 50%

- Myoglobin has **great effectiveness in excluding of MI** (when there is no increase of myoglobin within 4 h from the first stenocardial symptoms it allows to exclude MI in 90-100%)
- Myoglobin is **useful in evaluation of effectiveness of fibrinolytic therapy**

## Troponin

Troponin is a protein complex located on the thin filament of striated muscles and consists of three isotypes:

**Troponin T (TnT)**- binds the troponin complex to tropomyosin

**Troponin I (TnI)**- functions to inhibit actomyosin ATP-ase

**Troponin C (TnC)**- regulates TnI activity by binding calcium

TnI and TnT have diagnostic value in the MI

TnI and TnT occur in 3 isoforms:

- cardiac isoform (cTnI and cTnT)
- fast myofibril isoform
- slow myofibril isoform

	TnI	TnT
<b>onset</b>	- 4,5 (4-6,5) h	5,0 (3,5-8,1) h
<b>peak value</b>	- 19,0 (12,8-29,8) h	18,0(12,8-75,0)h
<b>decrease to</b>		
<b>normal range</b>	- 168,0 (105-168) h	172 (147-296) h

- **specificity to myocardium**
  - cTnI reveals **absolute** specificity to myocardium
  - cTnT high, but not 100% specificity to myocardium
  - \*increased value of cTnT may be observed in:
    - chronic renal failure
    - muscular dystrophy
    - polymyositis
- **diagnostic sensitivity**
  - after 4 h from the first symptoms of MI- 50%
  - after 6 h from the first symptoms of MI- 70%
- measurement of TnT and TnI is **useful in evaluation of minor myocardial injury** (two cut-off values)
- measurement of TnT and TnI is **useful in evaluation of risk of complications of unstable angina pectoris**

## Myocardial infarction – cardiac markers

### \* early diagnosis

- MYOGLOBIN
- CK-MB isoforms

### \* definitive diagnosis

- CK-MB
- TROPONIN

### \* late diagnosis

- TROPONIN
- LDH

## Brain natriuretic peptide (BNP) and N-terminal pro-B-type natriuretic peptide (NT-proBNP)

**I. BNP and NT-proBNP production** within the heart ventricles as a result of increased pressure and diastolic overload

**II. Main effects** of BNP and NT-proBNP

- a) reduction of blood pressure by arterial and venous vasodilatation
- b) natriuretic and diuretic effects by increasing GFR and decreasing sodium reabsorption within the nephrons
- c) inhibition of sympathetic system and renin-angiotensin-aldosterone system

**III. Significance** of BNP and NT-proBNP evaluations in **congestive heart failure (CHF)**

- a) **diagnostic** value (threshold value - 80 pg/ml, increased levels in CHF)
- b) **prognostic** significance (higher values associated with poor prognosis)
- c) **therapeutic** value (nesiritid - recombinant human BNP used in decompensated CHF)

**IV. Significance** of BNP and NT-proBNP evaluations in **acute coronary syndromes (ACS)**

- a) diagnostic value (ischaemia induces BNP and NT-proBNP releasing, but the diagnostic importance has not been established so far, according some authors these peptides may be used as a substitutive ischaemic marker)
- b) **prognostic** significance (higher levels are associated with increased early/late mortality and progression of heart failure independently of troponin and CRP elevation; this linear correlation is especially observed in NSTEMI, threshold value has not been established)
- c) influence on therapeutic strategy (some data indicate beneficial effects after early applying invasive methods among patients with ACS and increased NT-proBNP levels, but it requires further evaluation)

## The differential diagnosis of disorders of lipid metabolism

Ewa Wysocka MD

### THE MOST IMPORTANT RISK FACTORS FOR THE DEVELOPMENT OF CORONARY HEART DISEASE (CHD)

LIFESTYLE	BIOCHEMICAL AND PHYSIOLOGICAL SIGNS <i>Submitting modification</i>	INDIVIDUAL SIGNS <i>Not submitting modification</i>
<ul style="list-style-type: none"><li>• Diet abounding with saturated fatty acids, cholesterol and calories</li><li>• <u>Smoking *</u></li><li>• Excessive alcohol consumption</li><li>• Small physical activity</li></ul>	<ul style="list-style-type: none"><li>• <u>↑ serum T-C *</u> (LDL-C) conc.</li><li>• ↑ serum TG conc.</li><li>• <u>↓ serum HDL-C conc. *</u></li><li>• <u>↑ blood pressure*</u></li><li>• obesity</li><li>• <u>hyperglycemia/diabetes *</u></li><li>• prothrombotic factors</li><li>• ↑ serum homocystein conc.</li></ul>	<ul style="list-style-type: none"><li>• <u>age *</u>: man <math>\geq 45</math> women <math>\geq 55</math></li><li>• <u>premature menopause*</u></li><li>• <u>early onset of CHD or other artery disease caused by atherosclerosis (familial history)*:</u> in men <math>&lt; 55</math> yr in women <math>&lt; 65</math> yr</li><li>• <u>symptoms of CHD or other artery disease caused by atherosclerosis *</u></li></ul>



## THE RISK CATEGORIES OF CHD'S INCIDENT (1)

### MILD RISK

1 or 2 of the mild risk factors

#### MILD RISK FACTORS

- LDL-C 130-159 mg/dL  
(3,4-4,1 mmol/L)  
T-C : 200-239 mg/dL  
(5,2-6,2 mmol/L)
- Blood pressure :  
SBP 140-159 mmHg  
and/or  
DBP 90-99 mmHg

### MODERATE RISK

1 moderate risk factor

#### MODERATE RISK FACTORS

- smoking
- LDL-C 160-210 mg/dL  
(4,1-5,4 mmol/L)  
T-C : 240-300 mg/dL  
(6,2-7,8 mmol/L)
- HDL-C : men  $\leq$  35 mg/dL  
(0,9 mmol/L)  
women  $\leq$  40 mg/dL  
(1,0 mmol/L)
- SBP 160-179 mmHg  
and/or  
DBP 100-109 mmHg
- Age: men  $\geq$  45  
women  $\geq$  55
- Premature menopause
- early onset of CHD or other  
artery diseases caused by  
atherosclerosis in first-relative:  
men  $<$  55  
women  $<$  65

## THE RISK CATEGORIES OF CHD'S INCIDENT (2)

### HIGH RISK

- 1 strong risk factor
- 2 moderate risk factors

### STRONG RISK FACTORS

- smoking 20 or more cigarettes /day
- LDL-C > 210 mg/dL  
(5,4 mmol/L)
- T-C > 300 mg/dL  
(7,8 mmol/L)
- SBP  $\geq$  180 mmHg  
and/or  
DBP  $\geq$  110 mmHg

### VERY HIGH RISK

- 1 very strong risk factor at least (especially CHD), or
- 2 strong risk factors at least, or
- 3 moderate risk factors at least

### VERY STRONG RISK FACTORS

- CHD already diagnosed
- other artery diseases caused by atherosclerosis, clinically documented
- familial hyperlipoproteinemia
- diabetes mellitus

## PRIMARY PREVENTION OF CORONARY HEART DISEASE (1)

1. Estimate the risk factors such as the lifestyle, individual signs, biochemical and physiological signs in person above 20 yr.
2. If one doesn't smoke and doesn't have risk factors such as his individual signs (not submitting modification), and his :

T-C < 230 mg/dL

(6,0 mmol/l)

glucose conc. < 126 mg/dL

(7,0 mmol/L)

blood pressure < 160/100 mmHg

## MILD RISK

- information about healthy lifestyle and rational feeding
  - the next control for :
    - T-C in 5 years
    - body weight – in 2 years
    - blood pressure (if normal) – in 2 years
  - if arterial hypertension is present, obtain BP < 140/90 mmHg
  - if overweight is diagnosed, encourage to lose weight.
3. If one has at least one of the following risk factors : smoking, T-C  $\geq$  230 mg/dL, SBP  $\geq$  160 mmHg, DBP  $\geq$  100mmHg, BMI  $\geq$  30,0 kg/m<sup>2</sup>, plasma glucose concentration  $\geq$  126 mg/dL, CHD or other artery disease caused by atherosclerosis, it is necessary to determine full lipid profile in serum, than estimate the category of general CHD' risk and perform proper proceeding

## PRIMARY PREVENTION OF CORONARY HEART DISEASE (2)

### MODERATE RISK

- recommend changing of the life style (diet in particular)
- obtain LDL-C < 160 mg/dL  
(4,1 mmol/L)
- obtain TG < 180 mg/dL
- obtain BP < 140/90 mmHg
- if significant overweight or obesity, recommend losing weight about at least 10%.

3. continued

### HIGH RISK

- recommend changing of the way of life (diet in particular)
- obtain LDL-C < 130 mg/dL(3,4 mmol/L)
- obtain TG < 180 mg/dL(2,0 mmol/L)
- control BP < 140/90 mmHg
- if significant overweight or obesity, recommend losing weight about at least 10%.

### VERY HIGH RISK

- recommend changing of the life style (diet in particular)
- obtain LDL-C < 100 mg/dL (2,6 mmol/L)
- obtain TG < 180 mg/dL (2,0 mmol/L)
- obtain HDL-C > 35 mg/dL (0,9 mmol/L) in men  
> 40 mg/dL (1,0 mmol/L) in women
- control BP < 140/90
- in diabetics : obtain well-controlled glycemia and/or serum LDL-C conc. < 100 mg/dL(2,6 mg/dL), TG conc. < 150 mg/dL (1,7 mmol/L), control BP < 130/85 mmHg
- if significant overweigh or obesity, recommend losing weight at least about 10%.

## SECONDARY PREVENTION OF CORONARY HEART DISEASE

### RISK FACTORS

- smoking
- lipids
  - LDL-C < 100 mg/dl (2,6 mmol/l)
  - TG < 180 mg/dl (2,0 mmol/l)
  - HDL-C : men > 35 mg/dl, women > 40 mg/dl
- BP control < 140/90 mmHg
- body weigh control
- physical activity
- drugs

### RECOMMENDATION

Lipids determination – according to myocardial infarction in 4-6 weeks

(it's possible during first 24 hours of acute coronary incident)

Goals: LDL-C < 100 mg/dL , TG < 180 mg/dL (without drugs)

LDL-C 100-130 mg/dL , TG 180-300 mg/dL

LDL-C >130 mg/dL , TG >300 mg/dL (drugs are necessary)

## HYPERHOMOCYSTEINEMIA

<b>mild</b>	<b>10(16) – 30 <math>\mu\text{mol/l}</math></b>
<b>moderate</b>	<b>30 - 100 <math>\mu\text{mol/l}</math></b>
<b>severe</b>	<b>&gt;100 <math>\mu\text{mol/l}</math></b>

## HYPERHOMOCYSTEINEMIA - MECHANISM OF DISEASE

The vascular lining has a limited capacity to metabolize homocystein (HCY).

### HCY as atherogenic factor

- auto-oxidation of HCY results in the production of :

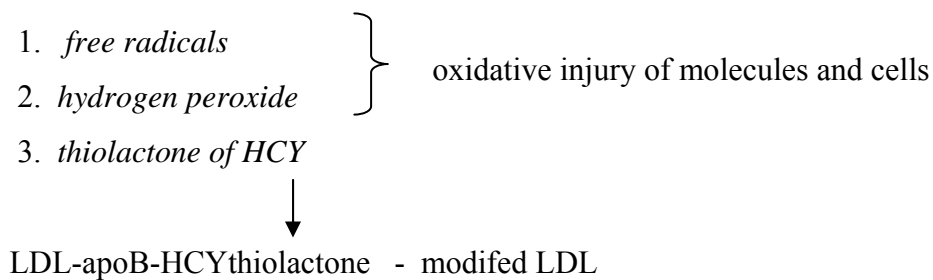

- limitation of biological access of NO (EDRF) for endothelial cells → impaired vasodilatation

### HCY as prothrombotic factor

- increases V and VII plasma factors activities
- decreases activity of protein C
- promotes the binding of Lp(a) to fibrin
- decreases the thrombomodulin expression
- increases expression of tissue factor
- lowers level of the natural cell surface anticoagulant (heparan sulfate)

## CAUSES OF HYPERHOMOCYSTEINEMIA

1. Congenital defects – deficiency of enzymes involved in HCY metabolism.
2. Acquired deficiency of folic acid, vit.B<sub>6</sub>, vit.B<sub>12</sub>.
3. Secondary causes: chronic renal failure  
neoplastic diseases  
hypothyroidism.
4. Drugs and substances:  
antagonized folic acid (methotrexate, phenytoine)  
antagonized vit.B<sub>6</sub> (theophylline, coffee).

## APPROACHES TO MANAGEMENT OF THE HYPERHCY-PATIENT

1. Screening for hyperHCY in selected high-risk patients:
  - Familial history of CHD  
(50% of patients with CHD had one or more first-degree relatives with hyperHCY)
  - Thromboembolic disease
  - Hypothyroidism
  - Chronic renal failure
  - Treatment with certain medications
2. Try to change HCY level by diet. Reassessment of the one month diet's results.
3. Verify the possibility of secondary causes (neoplastic disease!).
4. Folic Ac. 400 µg daily.

If HCY level is still elevated:

5. Folic Ac. 1 mg + Vit.B<sub>6</sub> 25 mg + Vit.B<sub>12</sub> 500 mg  
daily.

## Secondary dislipoproteinemias (1)

CLINICAL DISORDER	↑ PLASMA LIPOPROTEIN	LIPOPROTEIN TYPE	PROPOSED MECHANISM
DIABETES MELLITUS	VLDL (chylomicrons)	4 (rarely 5)	<ul style="list-style-type: none"> <li>• ↑secretion of VLDL</li> <li>• ↓catabolism of VLDL and Chylo due to ↓ LPL act.</li> <li>• glycation and oxidation of LDL</li> </ul>
	LDL	2a, 2b	
HYPO-THYROIDISM	LDL (IDL)	2a (rarely 3)	<ul style="list-style-type: none"> <li>• ↓ catabolism of VLDL and IDL</li> </ul>
CUSHING'S SYNDROME	LDL (VLDL)	2a or 2b	<ul style="list-style-type: none"> <li>• ↑ secretion of VLDL with conversion to LDL</li> </ul>
ACROMEGALY	VLDL	4	<ul style="list-style-type: none"> <li>• ↑ secretion of VLDL</li> </ul>
ANOREXIA NERVOSA	LDL	2a	<ul style="list-style-type: none"> <li>• ↓ biliary excretion of CH and bile acids</li> </ul>
OVERWEIGHT / OBESITY	VLDL	4	<ul style="list-style-type: none"> <li>• ↑ secretion of VLDL</li> </ul>
ALCOHOL	VLDL (chylomicrons)	4 (rarely 5)	<ul style="list-style-type: none"> <li>• ↑ secretion of VLDL in individuals genetically predisposed to hyperTAG</li> </ul>
ORAL CONTRACEPTIVES	VLDL (chylomicrons)	4 (rarely 5)	<ul style="list-style-type: none"> <li>• ↑ secretion of VLDL in individuals genetically predisposed to hyperTAG</li> </ul>
GLUCOCORTICOIDES	LDL (VLDL)	2a or 2b	<ul style="list-style-type: none"> <li>• ↑ secretion of VLDL with conversion to LDL</li> </ul>



## Secondary dislipoproteinemias (2)

CLINICAL DISORDER	↑ PLASMA LIPOPROTEIN	LIPOPROTEIN TYPE	PROPOSED MECHANISM
UREMIA	VLDL	4	<ul style="list-style-type: none"> <li>↓ catabolism of VLDL due to reduced LPL activity</li> </ul>
NEPHROTIC SYNDROME	LDL VLDL	2a or 2b	<ul style="list-style-type: none"> <li>↓ catabolism of LDL and VLDL (proteinuria)</li> </ul>
ACUTE HEPATITIS (non-fulminant)	VLDL	4	<ul style="list-style-type: none"> <li>↓ hepatic secretion of LCAT</li> </ul>
HEPATOMA	LDL	2a	<ul style="list-style-type: none"> <li>lack of feedback inhibition of hepatic CH synthesis by dietary cholesterol</li> </ul>
SEVERE STRESS acute myocardial infarction, extensive burns	VLDL	4	<ul style="list-style-type: none"> <li>↑ secretion and ↓ catabolism of VLDL</li> </ul>
SYSTEMIC LUPUS ERYTHEMATOSIS	chylomicrons	1	<ul style="list-style-type: none"> <li>presence of IgG or IgM that binds heparin - ↓ LPL activity</li> </ul>
MONOCLONAL GAMMAPATIES	chylomicrons IDL VLDL	3 or 4	<ul style="list-style-type: none"> <li>presence of IgG or IgM that forms immune complex with chylomicron remnants and/or VLDL - ↓ catabolism of VLDL</li> </ul>

## Third Report of the National Cholesterol Education Program (NCEP) Expert Panel and Detection, Evaluation, and Treatment of High Blood Cholesterol in Adults

Adult Treatment Panel III (ATP III) 2003, *still recommended in 2006*

Total Cholesterol Levels (T-C)	
Less than 200 mg/dl	"Desirable" level that puts you at lower risk for heart disease. A cholesterol level of 200 mg/dL or greater increases your risk.
200 to 239 mg/dl	"Borderline-high"
240 mg/d and above	"High" blood cholesterol. A person with this level has more than twice the risk of heart disease compared to someone whose cholesterol is below 200 mg/dl.

LDL-Cholesterol Levels (LDL-C)	
Less than 100 mg/dl	Optimal
100 to 129 mg/dl	Near Optimal/ Above Optimal
130 to 159 mg/dl	Borderline High
160 to 189 mg/dl	High
190 mg/dl and above	Very High

## **Third Report of the National Cholesterol Education Program (NCEP) Expert Panel and Detection, Evaluation, and Treatment of High Blood Cholesterol in Adults**

Adult Treatment Panel III (ATP III) 2003, *still recommended in 2006*

<b>HDL-Cholesterol Levels (HDL-C)</b>	
Less than 40 mg/dl	A major risk factor for heart disease
40 to 59 mg/dl	The higher your HDL, the better
60 mg/dl and above	An HDL of 60 mg/dl and above is considered protective against heart disease

<b>Triglyceride Levels (TG)</b>	
Less than 150 mg/dl	Normal
150 to 199 mg/dl	Borderline-high
200-499 mg/dl	High
500 mg/dl or above	Very High

## The diagnosis of hyper- and hypoglycemia

*Ewa Wysocka MD*

The information presented in the chapel has been updated to the latest recommendation of American Diabetes Association:  
Standards of Medical Care in Diabetes. Diabetes Care, vol. 29, suppl.1, January 2006

### THE DEFINITION OF DIABETES MELLITUS

Metabolic disease of various etiologies, characterized by:

- chronic hyperglycemia with  $\left\{ \begin{array}{l} \text{carbohydrate} \\ \text{lipid} \\ \text{protein} \end{array} \right\}$  metabolism disorders  
due to an absolute or a relative lack of insulin
- occurrence of the late diabetic complications (microangiopathy, macroangiopathy, neuropathy and cataract).

### THE CATEGORIES OF FASTING GLYCEMIA

FASTING GLYCEMIA	NORMAL	BORDERLINE GLUCOSE LEVELS	DIABETES MELLITUS	
VENOUS BLOOD PLASMA	$< 100 \text{ mg/dL}$ $< 5,6 \text{ mmol/L}$	$100 - 125 \text{ mg/dL}$ $5,6 - 6,95 \text{ mmol/L}$	$\geq 126 \text{ mg/dL}$ $\geq 7,0 \text{ mmol/L}$	
WHOLE VENOUS BLOOD	$< 85 \text{ mg/dL}$ $< 4,73 \text{ mmol/L}$	$85 - 109 \text{ mg/dL}$ $4,73 - 6,05 \text{ mmol/L}$	$\geq 110 \text{ mg/dL}$ $\geq 6,1 \text{ mmol/L}$	*
WHOLE CAPILLARY BLOOD	$< 85 \text{ mg/dL}$ $< 4,73 \text{ mmol/L}$	$85 - 109 \text{ mg/dL}$ $4,73 - 6,05 \text{ mmol/L}$	$\geq 110 \text{ mg/dL}$ $\geq 6,1 \text{ mmol/L}$	*

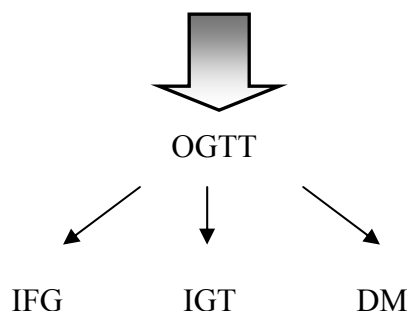

\* Approximately 12 – 18 mg/dL lower concentrations of fasting glucose are observed in whole blood (venous or capillary) comparing with venous blood plasma

## ORAL GLUCOSE TOLERANCE TEST (OGTT)

INDICATIONS	CONTRAINDICATIONS absolute
1. Abnormal (borderline) fasting glycemia; 5,6 mmol/L (100-125 mg/dL).	1. The diagnosis of DM was made.
2. Glucosuria with normal fasting glucose concentration.	2. Some gastrointestinal diseases; malabsorption syndrome, after stomach resection.
3. The diagnostic way of gestational diabetes mellitus (GDM).	CONTRAINDICATIONS relative – about 4-6 weeks
4. In persons with high risk of especially type 2 DM, i.e. metabolic syndrome with normal fasting glycemia. It is recommended to perform OGTT every 2 years in obese children and youth.	1. Severe acute states. 2. Long-term physical inactivity.

### TEST STANDARDIZATION

1. Patient's diet – approximately 300g of carbohydrates/day for 3 days preceding the test (at least 150g/day).
2. Usual physical activity.
3. Drugs (taking by patients) which can influence blood glucose conc.
4. Smoking is not allowed.
5. In the morning, after 8-14 hours fasting.
6. The oral glucose load:

ADULTS

75g

CHILDREN

1.75g/kg body weight  
(max.75g)

PREGNANT WOMEN

75g  
50 and 100g

- dissolved in 250-300 ml of water
- drinking within 5 minutes.

**ORAL GLUCOSE TOLERANCE TEST (75,0g of glucose)  
- RESULTS' INTERPRETATIONS**

<b>CATEGORY</b>	<b>BLOOD SAMPLES</b>	<b>FASTING GLYCEMIA, AT 0 MIN.</b>	<b>GLYCEMIA AT 120 MIN.</b>
<b>normal values</b>	VENOUS BLOOD PLASMA	<b>&lt; 100 mg/dL</b> <i>&lt; 5,6 mmol/L</i>	<b>&lt; 140 mg/dL</b> <i>&lt; 7,8 mmol/L</i>
<b>Impaired Fasting Glycemia, Isolated IFG</b>	VENOUS BLOOD PLASMA	<b>100 – 125 mg/dL</b> <i>5,6 – 6,95 mmol/L</i>	<b>&lt; 140 mg/dL</b> <i>&lt; 7,8 mmol/L</i>
<b>Impaired Glucose Tolerance, Isolated IGT</b>	VENOUS BLOOD PLASMA	<b>&lt; 100 mg/dL</b> <i>&lt; 5,6 mmol/L</i>	<b>140 –199 mg/dL</b> <i>7,8 – 11,05 mmol/L</i>
<b>IFG &amp; IGT</b>	VENOUS BLOOD PLASMA	<b>100 – 125 mg/dL</b> <i>5,6 – 6,95 mmol/L</i>	<b>140 –199 mg/dL</b> <i>7,8 – 11,05 mmol/L</i>
<b>DIABETES MELLITUS</b>	VENOUS BLOOD PLASMA	<b>&lt; 126 mg/dL</b> <i>&lt; 7,0 mmol/L</i>	<b>≥ 200 mg/dL</b> <i>≥ 11,1 mmol/L</i>

## THE CRITERIA FOR DIAGNOSIS OF DIABETES MELLITUS

1. The classic diabetic symptoms : polyuria, polydipsia and unexplained weight loss

and

a casual plasma glucose conc. (random glycemia)  $\geq 200$  mg/dL (11,1 mmol/L)  
(casual is defined as any time of day without regard to time since last meal).

2. Fasting plasma glucose (FPG) conc.  $\geq 126$  mg/dL (7,0 mmol/l) stated twice  
(fasting is defined as no caloric intake for at least 8h).

3. Pathological result of OGTT :

a 2-hour postload plasma glucose conc.  $\geq 200$  mg/dL (11,1 mmol/L).

- In the absence of unequivocal hyperglycemia, these criteria should be confirmed by repeat testing on a different day.
- These diagnostic criteria apply to children as well as adults.
- Pregnant women undergo special diagnostic way.
- The OGTT must be performed according to WHO specifications.

(AMERICAN DIABETES ASSOCIATION, Standards of Medical Care in Diabetes  
Diabetes Care, vol. 29, suppl.1, January 2006):

1. The FPG is the preferred test to screen for pre-diabetes and diabetes.

2. The OGTT is not recommended for routine clinical use, but may be required

- in the evaluation of patients with IFG
- when diabetes is still suspected despite a normal FPG
- during the postpartum evaluation of women with GDM.

## GESTATIONAL DIABETES MELLITUS (GDM)

(ADA recommendation 2006)

### Low risk for GDM

Low-risk status requires no glucose testing, but this category is limited to those women meeting **all of the following** characteristics:

1. Age < 25 yrs.
2. BMI or weight normal before pregnancy.
3. Member of an ethnic group with a low prevalence of GDM.
4. First-degree relative without diabetes.
5. No history of abnormal glucose tolerance.
6. No history of obstetric complications.

### Screening OGTT (glucose challenge test – GCT)

- doesn't require an overnight fast
- **50,0g** glucose dose
- blood sample is drawn after 1 hour
- plasma glucose conc.: < 140 mg/dL (7,8 mmol/L) rules out GDM  
≥ 140 mg/dL (7,8 mmol/L) requires a full diagnostic test.

### Diagnostic OGTT

- requires an overnight fast (8-14 hours)
- **100,0g** glucose dose
- blood samples are drawn just before and 1,2,3 hours after
- plasma glucose conc. elevated in at least 2 of 4 samples → GDM

## ORAL GLUCOSE TOLERANCE TEST IN PREGNANT WOMEN - NORMAL VALUES

(ADA - 100,0g of glucose)

	FASTING GLYCEMIA	GLYCEMIA AT 60 MIN.	GLYCEMIA AT 120 MIN.	GLYCEMIA AT 180 MIN.
VENOUS BLOOD PLASMA	< 95 mg/dl < 5,3 mmol/l	< 180 mg/dl < 10,0 mmol/l	< 155 mg/dl < 8,6 mmol/l	< 140mg/dl < 7,8 mmol/l



## THE MANAGEMENT OF GESTATIONAL DIABETES MELLITUS

I. Risk assessment for GDM should be undertaken at the first prenatal visit:

1. Fasting plasma glucose (FPG) concentration:

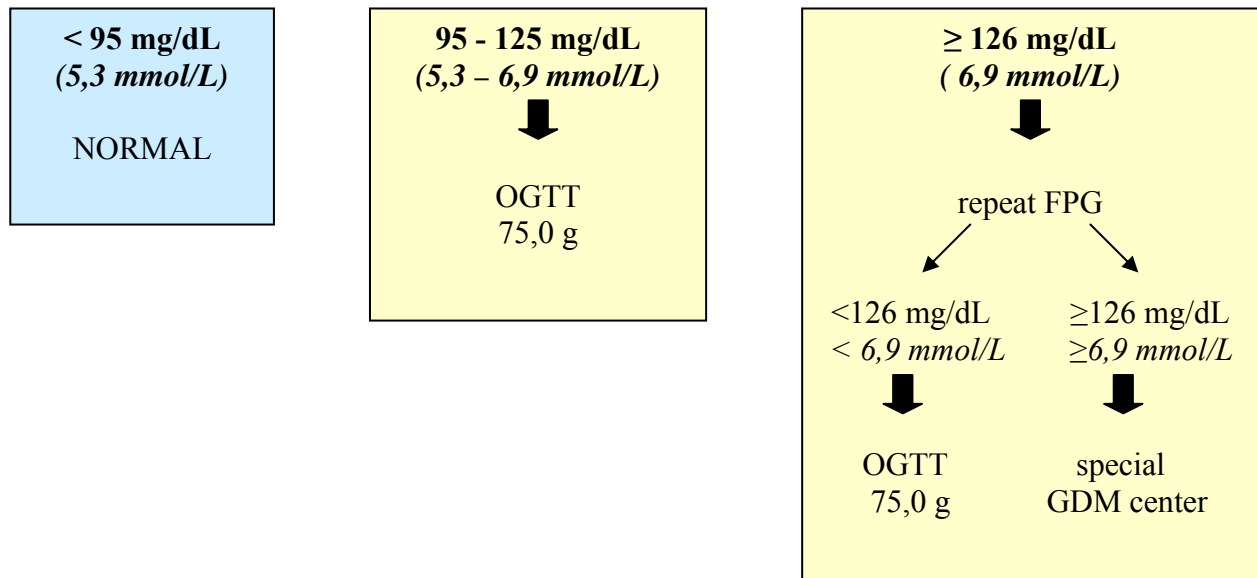

- Interpretation in compliance with WHO recommendation :

$$\text{GDM when 120' glycemia is } \left\{ \begin{array}{l} 140-199 \text{ mg/dL (7,8-11,0 mmol/l)} \\ \text{or} \\ \geq 200 \text{ mg/dL (11,1 mmol/l)}. \end{array} \right.$$

- High-risk women not found to have GDM at the initial screening and average-risk women should be tested between 24 and 28 weeks of gestation.

2. Between 24 and 28 weeks of gestation OGTT should be performed:

- A. One-step approach: perform a 75-g OGTT
- B. Two-step approach:
  - 1) an initial screening with glucose challenge test (GCT)
  - 2) a diagnostic 75-g OGTT.

ADA 2005: "The diagnosis can be made using a 75-g glucose load, but that test is not as well validated for detection of at-risk infants or mothers as the 100-g OGTT."

**ADA recommends 100-g OGTT.**

II. The consequences of the diagnosed IFG during pregnancy are still unknown.

III. GDM women should be screened for diabetes 6-12 weeks postpartum, to verify diagnosis :

- Approximately 10% of GDM women fulfill criteria for diabetes. They are reclassified as having DM.
- Approximately 5-10% women continue to have abnormal glucose metabolism below diabetic levels. They are reclassified as having IFG or IGT.
- 30% of GDM women become diabetic within the next 5 to 10 years.

## THE RISK FACTORS FOR TYPE 2 DIABETES MELLITUS

(Criteria for testing for diabetes – European standards)

1. Obesity (BMI  $\geq 25$  kg/m<sup>2</sup>).
2. First-degree relative with diabetes.
3. Habitual physical inactivity.
4. Belonging to a high-risk ethnic or racial group.
5. Previous evidence of impaired glucose homeostasis.
6. GDM in the past history.
7. Having delivered a baby weighing  $>4,0$  kg.
8. Arterial hypertension ( $\geq 140/90$  mmHg).
9. Dyslipidemia: HDL cholesterol conc.  $< 40$  mg/dl ( 1,0 mmol/l)  
and/or  
TG conc.  $\geq 250$  mg/dl (2,85 mmol/l)
10. Other clinical states associated with insulin resistance  
(i.e. polycystic ovary or *acanthosis nigricans*).
11. Symptoms of CVD.

Screening for DM should start:

- At **age 45** years and be repeated **every 3 years** in persons without any risk factor
- Earlier and more frequently in those with at least one factor of the above list.

## **CRITERIA FOR TESTING FOR DIABETES IN ASYMPTOMATIC ADULT INDIVIDUALS**

American Diabetes Association 2006

1. Testing for diabetes should be considered in all individuals at age 45 years and above, particularly in those with a BMI  $\geq 25$  kg/m<sup>2</sup> \* and, if normal, should be repeated at 3-year intervals.
2. Testing should be considered at a younger age or be carried out more frequently in individuals who are overweight (BMI  $\geq 25$  kg/m<sup>2</sup> \*) and have additional risk factors, as follows:
  - are habitually physically inactive
  - have a first-degree relative with diabetes
  - are members of a high-risk ethnic population (e.g., African American, Latino, Native American, Asian American, Pacific Islander)
  - have delivered a baby weighing  $>9$  lb (4,0 kg) or have been diagnosed with GDM
  - are hypertensive ( $\geq 140/90$  mmHg)
  - have an HDL cholesterol level  $<35$  mg/dl (0.90 mmol/l) and/or a triglyceride level  $>250$ mg/dl (2.82 mmol/l)
  - have PCOS (polycystic ovary syndrome)
  - on previous testing, had IGT or IFG
  - have other clinical conditions associated with insulin resistance (acanthosis nigricans)
  - have a history of vascular disease

\*May not be correct for all ethnic groups.

## **TESTING FOR TYPE 2 DIABETES IN CHILDREN - CRITERIA**

American Diabetes Association 2006

- **Overweight** (BMI  $>85$ th percentile for age and sex, weight for height  $>85$ th percentile, or weight  $>120\%$  of ideal for height)
- plus**  
**any two** of the following risk factors:
- Family history of type 2 diabetes in first or second-degree relative
  - Race/ethnicity (Native American, African American, Latino, Asian American, Pacific Islander)
  - Signs of insulin resistance or conditions associated with insulin resistance (acanthosis nigricans, hypertension, dyslipidemia, or PCOS)
  - Maternal history of diabetes or GDM

Age of initiation: age 10 years or at onset of puberty, if puberty occurs at a younger age

Frequency: every 2 years

Test: FPG preferred

# CLASSIFICATION OF GLYCEMIA DISTURBANCES

## CATEGORIES (STAGES)

- normoglycemia

- hyperglycemia :

### 1. Impaired regulation of glucose metabolism:

- a) Impaired glucose tolerance – IGT
- b) Impaired fasting glycemia – IFG

### 2. Diabetes mellitus:

- a) does not require insulin,
- b) requires insulin to well metabolic control,
- c) requires insulin to survival.

## ETHIOLOGICAL TYPES (PROCESSES)

### TYPE 1

- Autoimmunologic,
- Idiopathic.

### TYPE 2

Combination of insulin resistance and insulin secretory defect.

### OTHER SPECIFIC TYPES

- Genetic defects of beta-cells function
- Genetic defects in insulin action
- Diseases of the exocrine pancreas
- Endocrinopathies  
(i.e. acromegaly, Cushing's syndrome, glucagonoma, pheochromocytoma, hyperthyroidism)
- Diabetes induced by drugs and other chemical substances, i.e. :
  - Vacor
  - Pentamidine
  - Nicotinic acid
  - Glucocorticosteroids
  - Thyroid hormones
  - Diazoxide
  - $\alpha$ -mimetics
  - $\beta$ -adrenolitics
  - Thiazids
  - Dilantin
  - $\alpha$ -Interferon
- Diabetes induced by viral infections
- Uncommon forms of immune mediated diabetes
- Genetic syndromes sometimes associated with diabetes

### GESTATIONAL DIABETES MELLITUS

Diabetes that begins in pregnancy

## THE METABOLIC SYNDROME

(European guidelines on cardiovascular disease prevention in clinical practice 2003,  
National Cholesterol Education Program in the USA, ATP III 2003)

We diagnose the metabolic syndrome if at least 3 of the following components are present

1. Central (abdominal) obesity:

perimeter of waist > 102 cm in man  
perimeter of waist > 88 cm in women

WHR for men > 0,90  
for women > 0,85

and/or BMI > 30 kg/m<sup>2</sup>

2. Plasma TAG conc.  $\geq$  150 mg/dl

3. Plasma HDL-CH conc. < 40 mg/dl in men , < 50 mg/dl in women  
(1,0 mmol/l) (1,3 mmol/l)

4. Blood pressure  $\geq$  130/85 mmHg

5. Fasting plasma glucose concentration  $\geq$  100 mg/dL (5,6 mmol/l)

## WORLDWIDE DEFINITION OF THE METABOLIC SYNDROME

The IDF (International Diabetes Federation) consensus – April 2005

To be defined as having the metabolic syndrome one must have	
<b>CENTRAL OBESITY</b>	
waist circumference for European men $\geq$ 94 cm and European women $\geq$ 80 cm <i>(with ethnicity specific values for other groups)</i>	
<b>plus any two of the following four factors:</b>	
1. raised TAG concentration or treatment for hypertriglyceridemia	$\geq$ 1,7 mmol/l (150 mg/dl)
2. reduced HDL- cholesterol conc.: males females or treatment for this lipid abnormality	$<$ 1,03 mmol/l (40 mg/dl) $<$ 1,29 mmol/l (50 mg/dl)
3. raised blood pressure: systolic or diastolic or antihypertensive treatment	$\geq$ 130 mmHg $\geq$ 85 mmHg
4. raised fasting plasma glucose (FPG) conc. or previously diagnosed t.2 DM	$\geq$ 5,6 mmol/l (100 mg/dl)
if FPG $\geq$ 5,6 mmol/l (100 mg/dl), OGTT is strongly recommended but is not necessary to define the syndrome	

## WORLDWIDE DEFINITION OF THE METABOLIC SYNDROME

- different criteria for central obesity in the world. IDF, 2005

Country/Ethnic group	Waist circumference	
<b>Europids</b>	male	≥ 94 cm
	female	≥ 80 cm
<b>in the USA</b> , the ATP III values are likely to continue to be used for clinical purpose	male	≥ 102 cm
	female	≥ 88 cm
<b>South Asians</b> based on a Chinese, Malay and Asian-Indian population	male	≥ 90 cm
	female	≥ 80 cm
<b>Chinese</b>	male	≥ 90 cm
	female	≥ 80 cm
<b>Japanese</b>	male	≥ 85 cm
	female	≥ 90 cm
<b>Ethnic South and Central Americans</b>	Use South Asian recommendations until more specific data are available.	
<b>Sub-Saharan Africans</b>	Use European data until more specific data are available.	
<b>Eastern Mediterranean and Middle East (Arab) populations</b>	Use European data until more specific data are available.	

## TESTING OF BLOOD GLUCOSE CONCENTRATION

- in general

1. The presence of classic diabetic symptoms – the diagnosis of diabetes.
2. The screening for diabetes – in the high risk groups.
3. The testing for carbohydrate metabolism in some specific situations :
  - chronic liver diseases
  - acute liver disease
  - acute pancreatitis
  - chronic pancreatopathy
  - acromegaly
  - Cushing syndrome
  - steroid therapy

## THE MONITORING OF DIABETES MELLITUS – LABORATORY TESTS

### LABORATORY TESTS FOR CHRONIC MONITORING

testing the threat of late diabetic complications:

- blood glucose levels and self-monitoring of blood glucose (SMBG):  
 fasting plasma glucose concentration (FPG),  
 postprandial (PPG) 1-2 h after the beginning of the meal,  
 profile of diurnal glycemia:

FULL	SHORTENED
fasting in the morning	fasting in the morning
before each main meal	
2 h after each main meal	2 h after each main meal
before sleeping	
at 24:00	
at 3:30	

- markers of backdating glycemia:  
 (glucosuria): 2-3 hours  
 glycated serum proteins, mainly albumin (fructosamine): 2-3 weeks  
 glycated hemoglobin (HbA<sub>1C</sub>): 2-3 months
- fasting lipid profile in blood: LDL-C, TG, HDL-C
- liver function tests (with further evaluation for fatty liver or hepatitis if abnormal)
- test for microalbuminuria
- renal function tests: creatinine in blood
- *thyroid-stimulating hormone (TSH) in type 1 DM, in type 2 if clinically indicated*
- routine urinalysis

LAB TESTS	FREQUENCY OF ORDERING	COMMENTS
blood glucose	depended on particular needs and goals	patients on insulin need SMBG more frequently than those not using insulin
HbA <sub>1C</sub> in blood	at least two times a year	Fig.16
fructosamine	not established	<ul style="list-style-type: none"> <li>• expecting results after adding to or modifying treatment,</li> <li>• if factors disturbing GHB measurements are present (Fig.16)</li> </ul>
lipids in blood	at least annually	more often if needed to achieve goals
urinalysis	annually	
microalbuminuria	annually	
creatinine in blood	annually	

## THE RELATIONSHIP BETWEEN HbA<sub>1C</sub> AND MEAN PLASMA GLUCOSE CONCENTRATION

according to the methods of HbA<sub>1C</sub> measurement certified in  
the National Glycohemoglobin Standardization Program NGSP, 2006 (www.ngsp.org)

HbA <sub>1C</sub> (%)	approximate mean plasma glucose concentration	
	mmol/L	mg/dL
4	3,5	65
5	5,5	100
6	7,5	135
7	9,4	170
8	11,4	205
9	13,3	240
10	15,3	275
11	17,2	310
12	19,2	345

Mean plasma glucose concentration – on multiple testing (glucose profiles) over 2-3 months. *Diabetes Care* 25:275-278,2002

## FACTORS THAT INTERFERE WITH HbA<sub>1C</sub> TEST RESULTS

updated 06/2006, www.ngsp.org

### 1. Hemoglobin Variants and Derivatives:

- genetic variants (e.g. HbS trait, HbC trait) and
- chemically modified derivatives of hemoglobin, i.e.:  
     carbamyated Hb in patients with renal failure,  
     acetylated Hb in patients taking large amounts of aspirin.

### 2. Shortened Erythrocyte Survival.

Any condition that shortens erythrocyte survival or decreases mean erythrocyte age (i.e. recovery from acute blood loss, hemolytic anemia) will falsely lower GHB test results regardless of the assay method used .

### 3. Other factors:

- Vitamins C and E are reported to falsely lower test results, possibly by inhibiting glycation of hemoglobin; vitamin C may elevate values with some assays as well.
- Iron-deficiency anemia is reported to increase test results.
- Hypertriglyceridemia,  
   Hyperbilirubinemia,  
   Uremia (see carbamyated Hb),  
   Chronic alcoholism,  
   Chronic ingestion of salicylates,  
   Opiate addiction

<p>are reported to interfere with some assay methods, falsely increasing results</p>
--



**CRITERIA FOR WELL-CONTROLLED DIABETES**  
- monitoring of glycemia

<b>CRITICALLY ILL PATIENTS</b>	
<b>plasma glucose level</b>	<b>close to 110 mg/dl</b> <i>6,1 mmol/l</i> generally < 180 mg/dl <i>10,0 mmol/l</i>
<b>NON-CRITICALLY ILL PATIENTS</b>	
<b>blood glucose levels</b>	
• fasting / preprandial	<b>90 - 130 mg/dL</b> <i>5,0 – 7,2 mmol/L</i> (midpoint of range 110 mg/dl)
• postprandial	<b>&lt; 180mg/dL</b> <i>&lt; 10,0 mmol/L</i>
<b>Hb A<sub>1C</sub></b> [%Hb}	<b>&lt; 7.0 %</b>
	<b>≤ 6,1 to ≤ 6,5 %</b>

**Key concepts in setting glycemic goals:**

1. Goals should be individualized.
2. Certain populations (children, pregnant women, and elderly) require special considerations.
3. Less intensive glycemic control may be indicated in patients with tendency to severe (or frequent) hypoglycemia.
4. More stringent glycemic goals (i.e. a normal HbA<sub>1C</sub> < 6 %) may further reduce complications at the cost of hypoglycemia (in type 1 DM especially)

**CRITERIA FOR WELL-CONTROLLED DIABETES**  
- monitoring of serum lipid concentrations

plasma <b>T-C</b> * mg/dl ( <i>mmol/l</i> )	<b>&lt; 175 (4,5)</b>	* not recommended by ADA 2006
plasma <b>LDL-C</b> mg/dl ( <i>mmol/l</i> )	<b>&lt; 100 (2,5)</b>	
plasma <b>LDL-C</b> ** mg/dl ( <i>mmol/l</i> )	<b>&lt; 70 (1,9)</b>	** if DM + CHD
plasma <b>HDL-C</b> mg/dl ( <i>mmol/l</i> )	Male: <b>&gt; 40 (1,0)</b> Female: <b>&gt; 50 (1,28)</b>	
<b>non-HDL – C</b> mg/dl ( <i>mmol/l</i> )	<b>&lt; 130 (3,4)</b>	
plasma <b>TAG</b> mg/dl ( <i>mmol/l</i> )	<b>&lt; 150 (1,7)</b>	

## TESTING FOR MICROALBUMINURIA

- in type 1 diabetic patients who have had diabetes for at least 5 years; in some case of pubertal children before 5 years of the disease,
- all patients with type 2 DM.

Screening for microalbuminuria can be performed by three methods:

1. Measurement of the albumin-to-creatinine ratio in a random urine specimen - preferred.
2. 24-h collection.
3. Timed (i.e. 4-h or overnight) collection.

Two of three specimens collected within a 3- to 6-months period should be abnormal.

<b>CATEGORY</b>	<b>spot collection mg/ 1g of creatinine</b>	<b>24-h collection mg/ 24 hrs</b>
<b>normal</b>	<b>&lt; 30</b>	<b>&lt; 30</b>
<b>microalbuminuria</b>	<b>30-299</b>	<b>30-299</b>
<b>macroalbuminuria</b>	<b>≥ 300</b>	<b>≥ 300</b>

The following factors may elevate urinary albumin excretion:

1. exercise within 24 hrs
2. infection
3. fever
4. congestive heart failure
5. marked hyperglycemia
6. marked hypertension.

**LABORATORY FINDINGS IN ACUTE SITUATIONS IN DIABETES**  
 Differential diagnosis of falling-in-coma diabetics because of glycemia disturbances:

ADA, Diabetes Care 27:suppl.1,2004

Figure 22.

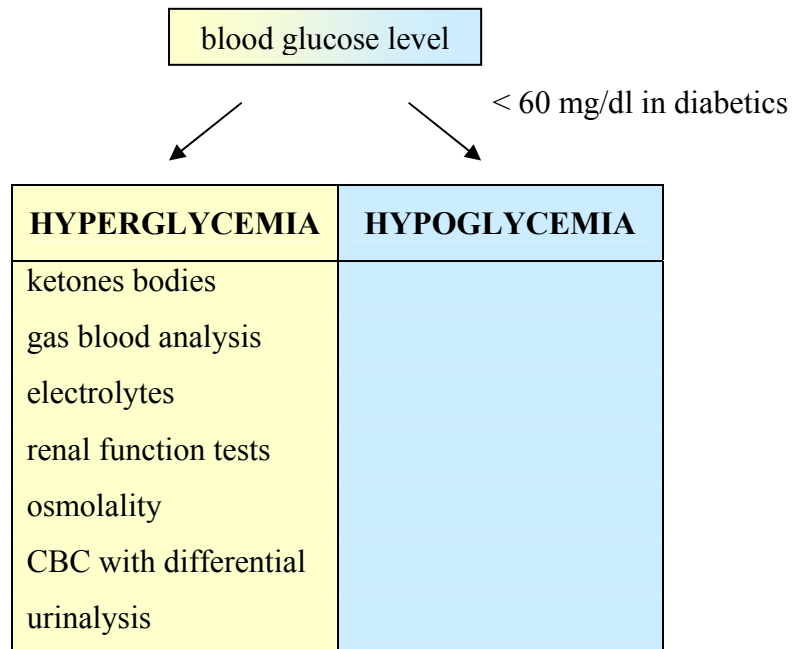

**THE EVALUATION OF KETONE BODIES**

1. Special meaning in the monitoring of:

- type 1 DM
- diabetic pregnant woman
- gestational diabetes
- acute diseases that can affect diabetes (i.e. severe inflammation enhances requirement for insulin)

2. In other situations make the decision of assessment, if:

- consistent hyperglycemia > 300 mg/dl (16,7 mmol/l) ,
- clinical symptoms of ketoacidosis

3. Patobiochemistry:

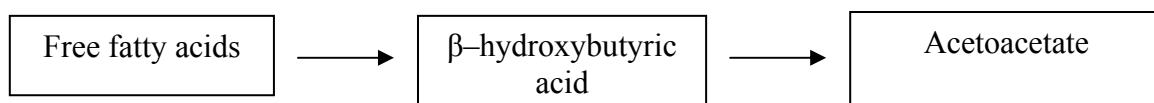

4. Measurement:

determined in blood

determined in urine  
by test strips

**DIAGNOSTIC CRITERIA FOR**

<b>DIABETIC KETOACIDOSIS ( D K A )</b>				<b>HYPERGLYCEMIC HYPERMOLAR STATE (H H S)</b>
<b>MILD</b>	<b>MODERATE</b>	<b>SEVERE</b>		
>250(14) [>350(19,4)]	>250 [>350]	>250 [>500(27,8)]	<b>GLUCOSE</b> mg/dL(mmol/L)	>600
7,25-7,35	7,00-7,24	<7,00	<b>pH</b>	>7,30
15-18	10-15	<10	<b>HCO<sub>3</sub><sup>-</sup></b> mmol/L	>15
+	+	+	<b>KETONURIA</b>	-/+
	c a n v a r y		<b>OSMOLALITY</b> mOsm/kg	>320
>10	>12	>12	<b>ANION GAP</b> mmol/L	<12
none	none or weakness/ sleepiness	sleepiness/ faintness/ stupor/coma	<b>DISTURBANCES OF CONSCIOUSNESS</b>	faintness/ stupor/ coma

## CAUSES OF HYPOGLYCEMIA

### FASTING HYPOGLYCEMIA

#### I. Underproduction of glucose.

##### A. Hormone deficiencies

1. Hypopituitarism
2. Adrenal insufficiency
3. Glucagon insufficiency

##### B. Enzyme defects

1. Glucose 6-phosphatase
2. Liver phosphorylase
3. Pyruvate carboxylase

##### C. Substrate deficiency

1. Ketotic hypoglycemia of infancy
2. Severe malnutrition
3. Late pregnancy

##### D. Acquired liver disease

1. Hepatic congestion
2. Severe hepatitis
3. Cirrhosis
4. Uremia

##### E. Drugs

1. Alcohol
2. Salicylates.

#### II. Overutilization of glucose

##### A. Hyperinsulinism

1. Insulinoma
2. Exogenous insulin
3. Autoimmune disease with antibodies
4. Endotoxic shock

##### B. Appropriate insulin levels

1. Extrapancratic tumors
2. Cachexia with fat depletion.

### REACTIVE (POSTPRANDIAL) HYPOGLYCEMIA

- I. Alimentary hyperinsulinism
- II. Hereditary fructose intolerance
- III. Galactosemia
- IV. Leucine sensitivity
- V. Idiopathic.

## LABORATORY DIAGNOSIS OF HYPOGLYCEMIA

1. PLASMA GLUCOSE CONC. < 45mg/dL (2,5 mmol/L)

2. IRI/G ratio  $\frac{\text{Insulin } (\mu\text{U/L})}{\text{glucose (mg/dL)}} < 0,3 (0,4)$

3. PLASMA C-PEPTIDE MEASUREMENT

1,0 –2,0  $\mu\text{g/L}$  (0,33-0,55 nmol/L)

4. PROLONGED FASTING

- during 24-72 hour fast – only liquids,
- blood glucose and insulin levels at least every 12 hours and at any time of hypoglycemic symptoms

5. OGTT

- the 5-hour OGTT,
- blood glucose and insulin concentrations.

6. SUPPRESSION OF ENDOGENOUS INSULIN

- 0,1 U/kg body weight insulin i.v. infusion
- within 60 min. plasma glucose conc. decreases to about 45 mg/dL and plasma C-peptide conc. < 1,2  $\mu\text{g/L}$

7. GLUCAGON PROVOCATIVE TEST

- 1 mg i.v.
- quick raise of glycemia and return to baseline within 90 minutes.

## Age-dependent characteristics of laboratory tests

*Sylvia Dziegielewska MD*

### Biochemical and physiological age-related changes and the consequences

Organ/System	Biochemical/Physiological Change	Consequence of Aging not Disease	Consequence of Disease not Aging
General	↑ body fat	Cholesterol/triglycerides/ glucose ↑ progressively	obesity, metabolic syndrome
Respiratory	↓ Lung elasticity and ↑ chest wall stiffness	↓ pO <sub>2</sub> approximately 5% every 15yr. after 30 ↑ pCO <sub>2</sub> approximately 2% every 10 yr. after 50	dyspnea, hypoxia, hypercapnia
Gastrointestinal	↓ hepatic function	↓ albumin 10-15% after 30 ↓ ALT, AST ↑ Clotting factors VII & VIII	cirrhosis
	↓ gastric acidity	↓ Ca <sup>2+</sup>	osteoporosis, B12 deficiency
Renal	↓ GFR	↓ creatinine clearance 0,8 ml/min/1yr after 40	↑ serum creatinine
Genitourinary	Prostate enlargement	↑ PSA	prostate cancer
Hematologic	↓ bone marrow reserve	↓ Hb, ↓ Ht, ↓ RBC	anemia
	↓ T cell function	↓ WBC	
	↑ Autoantibodies	↑ IgA, ↓ IgG & IgM, false-positive RF	autoimmune diseases
Endocrine	Impaired Glucose Homeostasis	<b>fasting glucose</b> ↑ 1-2 mg/dl/10 yr. after 40 <b>postprandial glucose</b> ↑ 4 mg/dl/10 yr. after 40	diabetes mellitus
	↓ thyroid hormone clearance and production	↓ T3 concentration	thyroid dysfunction
	↑ ADH, ↓ rennin, ↓ aldosterone	↑ ADH, ↓ rennin, ↓ aldosterone	↓ Na <sup>+</sup> , ↑ K <sup>+</sup>
	↓ Testosterone	↓ Testosterone	impotence
	↓ calciferol absorption and activation	↓ 1,25 (OH) <sub>2</sub> vit D	osteoporosis, fractures
Musculoskeletal	↓ Bone density	↑ Alkaline phosphatase	

## Diseases screening according to age

- Age-dependent diseases: definitely occurring with age

eg. cataracts, vulvovaginal atrophy (women), nodular prostate hyperplasia (men), brain cell loss, weak immune system (monoclonal gammopathy)

- Age-related diseases: increasing in prevalence with age

eg. arteriosclerosis (stroke, heart attack, etc.), myelodysplastic syndrome, plasma cell myeloma, hypertension, type II diabetes, Alzheimer's disease, idiopathic Parkinson's disease, cancer: skin, breast, prostate, colon, "atrophic gastritis" (stomach cancer precursor), chronic renal failure, heart failure, Paget's disease of bone, glaucoma, iatrogenic disease and polypharmacy ("vulnerability to infections")

Disease	Recommendations	Comments	Organization
diabetes mellitus	<b>Fasting glucose</b> at 3 years interval, men & women $\geq 45$ yr., earlier and more often in patient with risk factors	Risk factors: 1. obesity $>25 \text{ kg/m}^2$ 2. family history of DM 3. membership of ethnic groups 4. IGT/IFG 5. GDM or mother with infant birth weight $>9 \text{ lb}$ or $4,5 \text{ kg}$ 6. HA $>140/90 \text{ mmHg}$ 7. HDL $< 35 \text{ mg/l}$ ( $0,9 \text{ mmol/l}$ ) or TG $\geq 200 \text{ mg/dl}$ ( $2,2 \text{ mmol/l}$ ) 8. PCO 9. history of CVD	ADA (2004)
cholesterol & lipid disorders	<b>Total cholesterol</b> and <b>HDL-cholesterol</b> periodicity based on risk factors men $\geq 35$ yr. women $\geq 45$ yr.	1. Age to stop screening is not established. 2. Optimal interval for screening is uncertain.	AAFP (2002) USPSTF (2001)
	<b>Fasting lipoprotein panel</b> every 5 years men and women $> 20$ yr.	NCEP III promote more aggressive primary prevention in persons with multiple risk factors for CHD	NCEP III (2002)
thyroid disease	Screen with <b>serum TSH</b> Women $\geq 35$ yr.	At 35 age and every 5 years thereafter	ATA (2000)
	Women $\geq 50$ yr.	Selective screening for patient with 1 or more general symptoms as fatigue, weight gain, depression	ACP (1998)
	Elderly	Periodic screening with sensitive TSH	AACE (2002)
chronic kidney disease	Every patient $>65$ yr. Cystatine C or GFR <b>GFR 60-89 mL/min/1,73 m<sup>2</sup> or less evaluate GFR every 3 months</b>	1. Evaluate CVD risk 2. measure BP 3. albumin and creatinine concentration in urine 4. RBC and WBC in urine	NKF (2003)



**Clinical manifestation of diseases in elderly may be misinterpreted as normal aging**

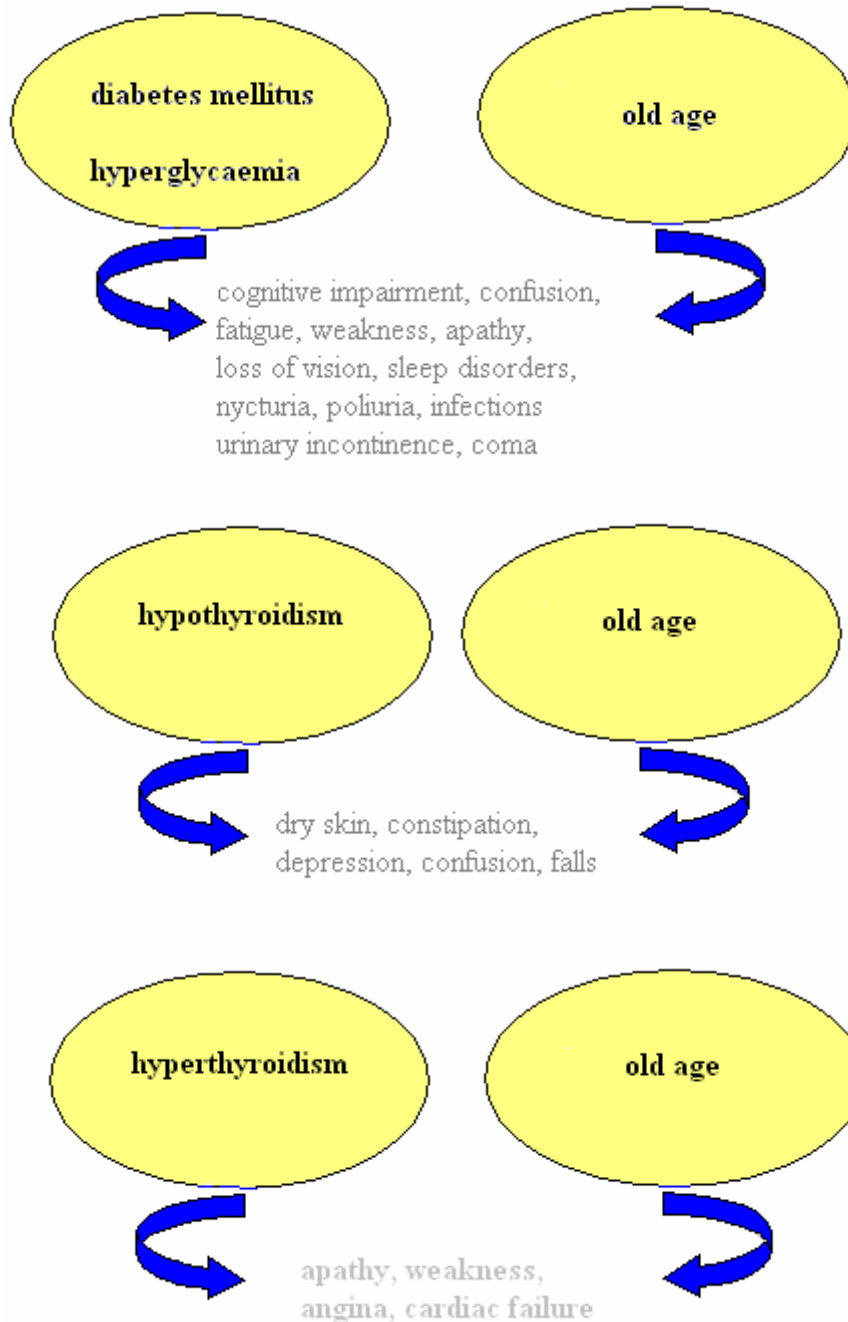

**to differentiate:**

**past history → physical examination → lab tests:**

- 1. CBC,**
- 2. glucose concentration,**
- 3. electrolytes,**
- 4. TSH, fT4, fT3,**
- 5. ALT, AST, GGTP,**
- 6. urine examination.**

Disease	Recommendations	Comments	Organization
heart failure	If suspected because of symptoms/signs – 1. ECG 2. X-Ray 3. <b>BNP</b>	BNP if available to identify patients with elevated left ventricular filling pressures, <b>marker of morbidity and mortality</b> in patients with known HF and as an aid in differentiating dyspnea due to HF from dyspnea due in other cases. Risk factors: 1. CHD 2. SBP $\geq$ 140 mmHg 3. CRP > 7 mg/l 4. DM 5. creatinine >1,4 mg/dL	ESC HF (2001)
prostate cancer	Asymptomatic men	Insufficient evidence to recommend for or against routine screening by PSA	NCI (2004) AAFP (2004)
colorectal cancer	Aged $\geq$ 50 yr.	FOBT annually + flexible sigmoidoscopy every 5 years or colonoscopy or barium enema	AAFP (2004)

### Age-dependent reference range for PSA

age	PSA (ug/L)
40-49	0,0-2,5
50-59	0,0-3,5
60-69	0,0-4,5
70-79	0,0-6,5

### Monitoring diseases in old patients

Disease	Recommendations	Comments	Organization
Diabetes Mellitus	1. glycemic control 2. lipids profile 3. micro- / macroalbuminuria 4. BP control < 130/80 mmHg 5. body weigh control 6. physical activity	1. Target hemoglobin A <sub>1c</sub> should be individualized. 2. A reasonable goal for <b>Hb A<sub>1c</sub> is 7%</b> or lower for relatively healthy elderly. 3. For frail older adults with <b>life expectancy of less than 5 years</b> and others in whom the risk of intensive glycemic control appear to outweigh the benefits appropriate <b>Hb A<sub>1c</sub> is 8%</b> 4. Elders should have his/her <b>Hb A<sub>1c</sub> measured at least every 6 months if individual target is not being met.</b> 5. For persons with <b>stable Hb A<sub>1c</sub></b> over several years measurement every <b>12 months</b> may be appropriate. 6. The goal is <b>100 mg/dL or less</b> in old adult with DM, when elderly patient with DM has an LDL cholesterol concentration of: 7. After initial screening and in the absence of previously demonstrated macro-microalbuminuria test for the presence of microalbumin should be performed annually.	ADA (2003/2004)

Disease	Recommendations	Comments	Organization
Heart Failure	Initial measurement of: 1. CBC 2. urinalysis 3. serum electrolytes (including Ca <sup>2+</sup> , Mg <sup>2+</sup> ) 4. BUN 5. serum creatinine and creatinine clearance 6. fasting glucose 7. lipids profile 8. liver function tests 9. TSH	1. Measurements for identifications of the disorder leading to HF – some of them are reversible or treatable. 2. If ACE inhibitors, aldosterone inhibitors – renal function and Na <sup>+</sup> , K <sup>+</sup> at start and after 2 weeks (avoid hyperkalemia). 3. If diuretics (loop, thiazides), digitalis – measure K <sup>+</sup> at frequent intervals to avoid hypokalemia	ACC/AHA (2003)
Coronary Heart Disease	1. lipids profile 2. glycemc control 3. electrolytes 4. BP control < 140/90 mmHg 5. body weigh control 6. physical activity	1. Age to stop monitoring is not established, the goals: LDL cholesterol <100 mg/dL (<70 mg/dL), HDL cholesterol : men > 45 mg/dL, women > 50 mg/dL, TG < 180 mg/dL <i>diabetics TG &lt; 150 mg/dL</i> <b>If LDL:</b> <b>100 mg/dL or less</b> – check lipid status at least every 2 years, <b>100-129 mg/dL</b> - check lipid status at least annually, MNT, increased physical activity <b>130 mg/dL or grater</b> - check lipid status at least annually, pharmacological therapy to achieve the goal  NCEP III promote more aggressive primary prevention in persons with multiple risk factors for CHD 2. when treatment control at frequent intervals electrolytes	AAFP (2002) USPSTF (2001)  NCEP III (2002)
Renal failure	1. electrolytes (Na <sup>+</sup> ,K <sup>+</sup> ,Cl <sup>-</sup> ,HCO <sub>3</sub> <sup>-</sup> ,Ca <sup>2+</sup> ) 2. CBC 3. serum albumin 4. PTH 5. BUN 6. lipids profile	To asses other clinical conditions common in renal failure	NKF (2003)

### 1. Measured creatinine clearance

$$cc \text{ (mL/min)} = [U \times V] / P$$

U- urine concentration of the creatinine (mg/dl)

P- plasma concentration of the creatinine (mg/dl)

V- urine flow rate (ml/min)

### 2. Estimated creatinine clearance according to the Cockcroft-Gault formula

$$cc \text{ (mL/min)} = [(140 - \text{age (years)}) \times \text{body mass (kg)}] / [72 \times \text{serum creatinine (mg/dL)}]$$

for women multiply by 0,85

## Palliative care for elderly people

According AAHPM 2004

Who is terminally ill?

Usually anyone who is 65 or older; or on hemodialysis and the patient's medical prognosis is 6 months or less, if the disease runs its normal course – 2 Physicians **MUST SIGN a statement about patient's medical prognosis**

How to determine prognosis of 6 month or less?

- **Heart disease** – recurrent heart failure or angina at rest – NYHA Class IV, patient already optimally treatment with diuretics and vasodilators, EF  $\leq$ 20%.
- **Pulmonary disease** - progressive pulmonary disease/respiratory failure, disabling dyspnea at rest
  1. Hypoxemia at rest on supplemental O<sub>2</sub>:
    - pO<sub>2</sub>  $\leq$  55 mmHg on supplemental O<sub>2</sub>
    - S O<sub>2</sub>  $\leq$  88% on supplemental O<sub>2</sub> **or**
  2. Hypercapnia
    - pCO<sub>2</sub>  $\geq$  50 mmHg
- **Liver disease** – end-stage cirrhosis – not candidate for liver transplant
  - PT > 5 sec or INR >1,5 and serum albumin <2,5 g/dlAt least one of : ascites despite diuretics and low sodium diet  
spontaneous peritonitis  
hepatorenal syndrome  
hepatic encephalopathy  
recurrent variceal bleed
- **Renal disease** – chronic renal failure, not a candidate for dialysis
  - creatinine clearance < 10 cc/min (for DM < 15 cc/min)
  - serum creatinine > 8,0 mg/dl (for DM > 6,0 mg/dl)
  - hyperkalemia – serum K<sup>+</sup> > 7,0 mmol/l

### 1. Traditional concept of diagnosis, treatment and palliative care

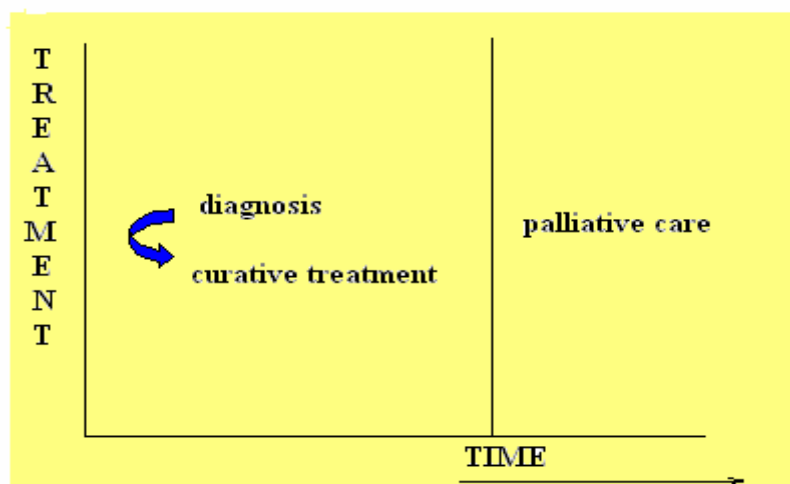

## 2. New concept of palliative care

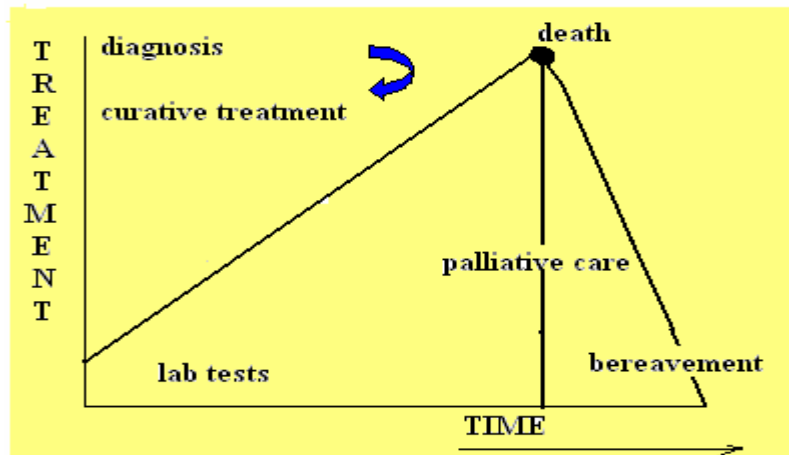

### ABBREVIATIONS

ACE	angiotensin-converting	HDL	high-density lipoprotein
enzyme		HF	heart failure
ADH	antidiuretic hormone	Hb	hemoglobin
ALT	alanine aminotransferase	Ht	hematocrit
ARB	angiotensin II receptor	IFG	impaired fasting glucose
blocker		IGT	impaired glucose tolerance
AST	aspartate aminotransferase	LDL	low-density lipoprotein
BNP	brain natriuretic peptide	NSAIDs	non-steroids anti-inflammatory drugs
CBC	complete blood count	PCO	polycystic ovary
CHD	coronary heart disease	PSA	prostate-specific antigen
CHF	congestive heart failure	RBC	Red Blood Cell
CVD	cardiovascular disease	RF	rheumatic fever
DM	diabetes mellitus	SBP	Systolic Blood Pressure
ECG	electrocardiography	TG	triglycerides
FOBT	fecal occult blood test	TSH	thyroid stimulating hormone
GDM	gestational diabetes mellitus	WBC	White Blood Cell
HA	hypertonia arterialis		

AACE	American Association of Clinical Endocrinologists
AAFP	American Academy of Family Physicians
ACP	American College of Physicians
ADA	American Diabetes Association
AHA	American Heart Association
ATA	American Thyroid Association
ESC	European Society of Cardiology
USPSTF	United States Preventive Services Task Force
NCEP III	National Cholesterol Education Program
NCI	National Cancer Institute
NKF	National Kidney Foundation

## REFERENCES

1. Braunwald E., Fauci A.S., Isselbacher K.J., Kasper D.J., Hauser S. L., Longo D. L., and Jameson J.L., „Harrison’s Principles of Internal Medicine” Part 1, Chapter 8: Geriatric Medicine, 16<sup>th</sup> ed. Mc Graw-Hill 2004-2005,
2. Beers M.H., Berkow R., „Merck Manual of Geriatrics” App. I Laboratory Values. Merck and Co, Inc., Internet Edition May 2005,
3. California Healthcare Foundation/American Geriatrics Society (AGS) Panel on Improving Care of Elders with Diabetes and approved by the AGS Board of Directors on February 25, 2003, “Guidelines for Improving the Care of the Older Person with Diabetes Mellitus”, JAGS 2003, 51:S265-S280,
4. “Heart Disease and Stroke Statistics — 2005 Update”, American Heart Association
5. Brigden M. L., Heathcote J. C., “Problems in interpreting laboratory tests, What do unexpected results man?” Postgrad. Med. 2000, Jun, Vol 107, No 7,
6. Levey AS, Coresh J, Balk E, Kausz AT, Levin A, Steffes MW, Hogg RJ, Perrone RD, Lau J, Eknoyan G, “National Kidney Foundation practice guidelines for chronic kidney disease: evaluation, classification, and stratification”, Ann Intern Med. 2003 Jul 15;139(2):137-47,
7. Finney H., Bates C.J., Price C.P., “Plasma cystatin C determinations in healthy elderly population”, Arch. Gerontol. Geriatr. 29: 75-94, 1999,
8. Fliser D., Ritz E., „Serum cystatin C concentrations as a marker of renal dysfunction in elderly“, Am. J. Kidney Dis. 2001, 1: 79-83,
9. Morgan T.O., Jacobsen S.J., Mc Carthy W.F., “Age specific reference ranges for serum prostate-specific antigen.” N. Engl. J. Med. 1996;335;304-310,
10. Lynn J. Adamson DM. „Living well at the end of life: adapting health care to serious chronic illness in old age.“ Arlington, VA, Rand Health 2003,
11. E. Davies and I.J. Higginson “Better Palliative Care for Older People” WHO on line recommendations 2003,
12. Fenigsen R., “The report of the Dutch Governmental Committee on Euthanasia” Issues Law Med. 1991 Winter;7(3):339-44.